



KA-6494N 4pcs A/C Spring Locking Coupling Tool Set

Release spring lock connector on air conditioning line for separating spring lock air conditioning refrigerant pressure lines on 1981-current ford cars and pick-up with spring lock connection.

They are spring-loaded in the closed position to deflect any spray that occurs when the line is disconnected. There are four sizes: 3/8", 1/2", 5/8", 3/4"



KA-6495N 4pcs Fuel Line Disconnect Tool Set

All the disconnect tools you need to work with quick connect fuel lines on ford, Chrysler, and GM and on the spring lock fuel line couplings on ford's popular port fuel injection system. Works on 5/16", 3/8" and 1/2", fuel lines.

F1 & F2 (3/8", 1/2"): release spring lock connectors on fuel line.

F3 & F4 (5/16", 3/8"): release quick connect fitting on fuel line.



KA-6494-9 9pcs A/C Fuel Line Disconnect Tool Set

A.A/C SPRING LOCKING COUPLING TOOL

There are four sizes : 3/8" (RED), 1/2" (BLUE-BLACK), 5/8" (BLACK), 3/4" (WHITE)

B.FUEL LINE DISCONNECT TOOL

3/8" (YELLOW) & 1/2" (GREEN): Releases spring lock connectors on fuel line.

5/16" (GRAY) & 3/8" (BLUE): Releases quick connect fitting on fuel line.

C.TRANSMISSION COOLER LINE AND FUEL LINE QUICK DISCONNECT TOOL

Removes push lock connectors found at both the radiator and transmission.

Tool slides down transmission cooler lines and fuel lines into the connector and spreads the plastic clip apart for easy removal.



KA-6494A A/C Spring Lock Coupling Tools

Used for separating spring lock air conditioning coupling on 1981-current Ford vehicles, and 1994 and newer Chrysler and Jeep vehicles. They provide the only means of separating air conditioning refrigerant pressure lines on these vehicles.



KA-6494-6 6pcs A/C Fuel Line Disconnect Tool Set

Includes six tools for disconnecting spring couplings on Ford, GM, and Chrysler air conditioning lines. Also works on fuel lines and can be used as push lock connectors on radiator and transmission lines.

Size: 5/16", 3/8", 1/2", 5/8", 3/4", 7/8"



KA-6494-7 7pcs A/C Fuel Line Disconnect Tool Set

- Easily disconnects air conditioning lines and quick connect fuel lines.
- Size include: 1/4", 5/16", 3/8", 1/2", 5/8", 3/4", 7/8"



KA-6494-10 Deluxe Fuel Line Disconnect Tool Set

- 3Pc. External Disconnect Tool Set to suit: VT & later Commodore, AU & later Falcon, TJ & later Magna, GM Opel & Vectra.
- Plus: 7Pc. Internal Disconnect Tool Set
- Sizes: 1/4", 5/16", 3/8", 1/2", 5/8", 3/4", 7/8".
- Works on all spring lock fuel line couplings fitted to today's EFI engines, also used on air conditioning lines.



KA-4345 3pcs External Disconnect Tool Set

- This external set works on Norma-Quick connect fuel lines found on the late model Ford, GM, Chrysler & Mitsubishi vehicles. They simply clip over the connector and release the spring lock. They will not damaged fuel lines or connectors.
- VT & later Commodore, AU & later Falcon, TJ & later Magna, GM Opel & Vectra.



KA-6410 Fuel Line Quick Disconnect Tool

- Tools service most type of quick-disconnect fittings used on Ford, GM & Chrysler vehicles.
- For easy fuel filter replacement 5/16" & 3/8".



KA-6409 Ford Fuel & A/C Line Spring Coupling Tool

- Releases locking mechanism on all four sizes of spring lock couplings on most Fords.
- Four separate sizes referenced 3/8", 1/2", 5/8" & 3/4".



KA-6408 2pcs Fuel & Air Condition Disconnect Tool Set

- Tools service most type of quick-disconnect fittings used on Ford, GM & Chrysler vehicles.
- 1pc - Ford/Chrysler/GM fuel line disconnect tool 5/16" & 3/8"
- 1pc - A/C & fuel line spring lock coupling tool 3/8", 1/2", 5/8" & 3/4"



KA-4341 Ford A/C And Fuel Line Spring Lock Coupling Tool

Set of both KA-6410 , KA-6409 & KA-5065



KA-4342 Ford A/C And Fuel Line Spring Lock Coupling Tool

Set of both KA-6410, KA-6409 & KA-5065

Ford/GM Quick Disconnected Tool

Set of KA-6406A



KA-4108 Ford Fuel Line Disconnect Tool - 5/16 x 3/8

- Ford Fuel Line Disconnect Tool - 5/16" x 3/8"
- Both Ends Required Due to Limited Clearance Between Fuel Line Connector End and Fuel Rail
- Services Transit 20L, 35 GTDI, 62L Boss Engines



KA-3526K 22pcs Fuel & Air Conditioning Line Disconnect Set

- A. 6pc fuel & air conditioning line disconnect set - 5/16", 3/8", 1/2", 5/8", 3/4", 7/8"
- B. Ford A/C spring lock coupling tool, red(3/8")
- C. Ford A/C spring lock coupling tool, blue(1/2")
- D. Ford A/C spring lock coupling tool, black(5/8")
- E. Ford A/C spring lock coupling tool, beige(3/4")
- F. Fuel line disconnect tool
- G. Ford oil cooler line disconnect tool
- H. Ford fuel line coupling tool
- I. Ford / GM quick disconnected tool
- J. 7pc A/C fuel line disconnect set
- K. K. Rubber band

KA-1265 Master Deluxe Line Disconnect Tool Set

- For separating Quick Disconnect fittings on fuel and cooler lines.
- Unique offset design allows for access in confined or obstructed areas.
- Easy, one-handed operation.
- Anodized aluminum construction.



KA-1265-1 (Dark Grey) Size: 1/2", Deluxe Line Disconnect Tool, for most 1/2" lines.

KA-1265-2 (Blue) Size: 5/8", Deluxe Line Disconnect Tool, for heater, A/C lines and more.

KA-1265-3 (Black) Size: 3/4", Deluxe Line Disconnect Tool, for heater, A/C lines and more.

KA-1265-4 (Silver) Size: 7/8", Deluxe Line Disconnect Tool, for heater, A/C lines and more.

KA-1265-5 (Red) Size: 5/16", Deluxe Line Disconnect Tool, for fuel & cooler lines.

KA-1265-6 (Gold) Size: 3/8", Deluxe Line Disconnect Tool, for fuel & cooler lines.

KA-1265-7 (Green) Size: 3/8", Deluxe GM Cooler Line Disconnect Tool, for transmission cooler lines.

KA-1265-8 (Pink) Size: 3/8", Deluxe Cooler Line Disconnect Tool, for cooler lines on most Ford vehicles and on 2003 to current Cadillac CTS.



KA-6677 4pcs Disconnect Tools

- Anodized aluminum
- Separates fittings on fuel lines, fuel filters & fuel tank return lines – sizes 1/4", 5/16", 3/8"

Oil Cooler Line Disconnect Tool

- Anodized aluminum
- Separates automatic transmission oil cooler lines on Ford Taurus and Escort with AXOD and ATX transmissions – size: 1/2"







KA-6677A 4pcs Fuel & Air Conditioning Line Disconnect Set

Sizes: 1/2", 5/8", 3/4", 7/8"

- Simple push-on and pull-off action.
- 4 popular sizes cover most cars.
- Color keyed for easy identification.
- Durable and soft powder coating will not scratch tubing.
- Thin lips slide under tight hose quickly.
- Easy to hold with greasy hands.
- Strong, light and durable aluminum construction.

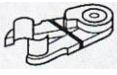

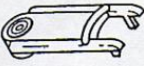
KA-6678 7pcs Fuel & Transmission Line Disconnect Set

	For Ford CFI fuel lines w/hair pin connectors; universal for radiator to transmission oil cooler lines: '87 & newer Olds. Toronado; Buick Riviera Reatta; Cadillac Eldorado, Seville, & Concours: 89' newer GM		<ul style="list-style-type: none"> ■ Anodized aluminum ■ Separates fittings on fuel lines, fuel filters & fuel tank return lines – sizes 1/4"
	1986 & newer Ford vehicles with AXOD; AOD, or ATX automatic transmissions		<ul style="list-style-type: none"> ■ Anodized aluminum ■ Separates fittings on fuel lines, fuel filters & fuel tank return lines – sizes 3/8"
	1990& newer Ford Rangers. & Explorers with 4.OL, 6 cylider engines		<p>OIL COIL COOLER LINE DISCONNECT TOOL</p> <ul style="list-style-type: none"> ■ Anodized aluminum ■ Separates automatic t transmission oil cooler lines on Ford Taurusand Escort with AXOD and ATX transmissions



KA-6678A

8pcs Fuel & Transmission Line Disconnect Set



KA-6678B 6pcs Disconnect Tools

5/16", 3/8", 1/2", 5/8", 3/4", 7/8"



KA-6678C

12pcs Fuel & Transmission & Air Conditioning Line Disconnect Set

- 1/4"-5/16"-3/8" A/C disconnect tool
- 5/16" & 3/8" Fuel line disconnect tool



KA-4354 Toyota A/C Disconnect Tool

- Used to release the plastic quick-connect fittings on the high and low pressure air conditioning lines at the evaporator.
- Services 1998- newer Toyota Corolla, 1998- newer Geo Prism, 1998- 1/2- newer Toyota Land Cruiser and Lexus LX470, 1999- newer Toyota Avalon, Camry, Solara, and Sienna mini vans.
- Easy to use: Plastic fitting on A/C line is rotated to show access to the two release holes in the fitting, tool is inserted into release holes and pushed to release the fitting.



KA-4353 Toyota Spring Lock Coupler Tool

- Disconnect tool for Toyota's new spring lock connectors.
- For use on 1998 and newer Toyotas.



KA-6801 Radiator Back Flusher

Fits 1/2", 5/8" & 3/4" (13, 16, 19mm) heater hoses uses compressed air and standard garden hose pressurized air & water cleans cooling systems & heater cores w/o disassemble causes solutions.

Keep radiator pressure cap in position to prevent over boosting. Saves costly replacement charge of the most stubbornly clogged heater cores.



KA-7257 Radiator Quick Coupler for SCANIA

- For SCANIA truck & bus
- Specialized quick change coupler for SCANIA 4 series, 5 series radiator cooling water supplement and replacement.



KA-7256 Cone Set

- Universal set suitable for radiator or expansion tank.
- Cone set consisting of three rubber cones with functional diameters:
 - 17mm~31mm
 - 24mm~39mm
 - 34mm~50mm
- Application in conjunction with vacuum-type cooling system filler.



KA-7258 Air Tubing Adaptor Clamp

- Grip the plastic tube, let the copper coupler can put into the tube easily.
- For truck, trailer and bus...etc





KA-5010 Universal Adjustable Spanner Wrench

- Adjustable locking pins can be used on all compressors
- Plastic-coated grip



Shaft Seal Protector

- KA-7486** Ø 11.3mm
- KA-7487** Ø 13.9mm



KA-7113 Fin Straightener And Cleaner

Multi-head tool handles 8, 9, 10, 12, 14, and 15 fins per inch. 4 1/4" long.



KA-7114 Fin Straightener

Fin straightener stainless steel, can clean & straighten evaporator or fin

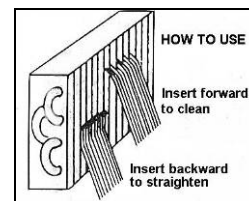

KA-7233K Fuel Line Disconnect Tool Set

- These tools can be used on many other makes of car where the connectors are the same.
- Simple operation will tell you when these tools will be used on other make or models.
- It is also possible that owing to a change in a given car model or connector that they do not work on all Renault, or Opel/G.M. cars.
- Applicable: Opel/G.M. · BUICK-PONTIAC
 Ø 8mm RENAULT Gasoline engines
 Ø 10mm RENAULT Diesel engines
 FORD-MERCURY · DODGE-CHRYSLER



KA-6508 O-Ring and Seal Pick

Both tools easy removal and installation of o-ring and seals



KA-7409 O-Ring Remove Tool

Material: SWPA8C



KA-6675 O-Ring Pick Up Tool

Material: Nylon



KA-3700 Clutch Plate Remover



KA-6829 Metric Clutch Plate Remover/Installer

- Same as AC10861MA except with metric threads
- One tool performs two functions
- Applications for GM DA6 and GM V5 compressors



KA-6830 Fractional Clutch Plate Remover/Installer

- One tool performs two functions
- Applications for GM A6 and GM R4 compressors



KA-3700

KA-6830

KA-7586K GM Clutch Plate Remover & Installer

- Tools remove and install clutches on GM air conditioning compressors.
- Remove clutch plate without removing retaining ring and install clutch plate with compressor on car. Use it on all A-6 and pre-1980 R-4 compressors. Tool will not work on metric threads.
- Contents
 - KA-3700** Clutch Plate Remover
 - KA-6830** Fractional Clutch Plate Remover & Installer



KA-7490 A/C Compressor Clutch Remover

- To remove the plate of clutch.
- For FS6 5P 148



KA-7491K A/C Compressor Clutch Plate Remover

For MITSUBISHI / SANDEN



KA-6619 A/C Compressor Clutch Remover Kit

These tools are designed to remove the clutch hub of compressor. There are two models of four Clutch Hub Remover in this tool kit. Some Removers also can install the clutch hub.

- Replace clutches found on FS6, C171, 6P & 148 compressor.
- Also GM R4 & A6, HR-6, DA-6 & V5 A/C compressors.
- And compressors of Sanden SD505, 507, 508, 510, 575, 708 and 709.
- 2 & 3 hole puller plate fits most clutches, the mechanical force does the pulling job.



KA-6828 A/C Clutch Hub Tool Kit

- Combo installer/remover tools
- Covers GM R4/A6 SAE-CT861, DA6/R4/HR6/V5 Metric-CT867, Ford FS6/Nippondenso-CT884, Sanden-CT305, ZEXEL-CT206
- Service manual with ID chart, air gaps, and torque specs
- Removable hinged lid



KA-6688 Deluxe Clutch Hub Puller / Installer Kit

- Kit contains a complete offering of A/C compressor clutch hub pullers and installers for GM, Ford, Chrysler and Imports.
- Includes a compressor identification chart and comes in a custom molded case.

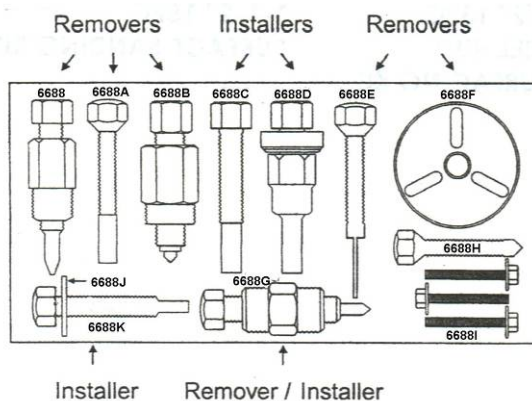

KA-7485K

General Motors A6, R4, Late DA6, HR-6, V5, 6 POLE R4 Seal Set

Includes the tools needed to replace seals on GM compressors from the early sixties through the current model year as well as Tecumseh HR-980

New type:

no more need "RUBBER BAND"



KA-3526KN 22pcs Fuel & Air Conditioning Line Disconnect Set

For extreme Weather and climate.

- 6pc fuel & air conditioning line disconnect set – 5/16", 3/8", 1/2", 5/8", 3/4", 7/8"
- Ford A/C spring lock coupling tool: red(3/8"), blue(1/2"), black(5/8"), beige(3/4")
- Fuel line disconnect tool
- Ford oil cooler line disconnect tool
- Ford fuel line coupling tool
- Ford / GM quick disconnected tool
- 7pc A/C fuel line disconnect set



KA-7535K Universal Orifice Tube Tool Kit

GM/Ford orifice tube remover and installation tool.
Also included is a screen extractor for CCOT system



KA-7482K Nippondens 10 PA17 Seal Set

- Includes all tools necessary to replace seals on Nippondenso. Used with tools from KA-7485K
- Contains:
 - A. Shaft Seal Remover
 - B. Shaft Seal Installer
 - C. Shaft Protector
 - D. Internal Snap Ring Remover



KA-7483K Sanden 507/508/510 Seal Set

All the specialized tools needed when replacing seals on Sanden Model 507, 508 and 510 compressor.
Used with tools from KA-7485K SET.



KA-7484K Sanden 505, 575 Service Set

- Includes all the necessary tools to service shaft seals on Sanden 505 and 575. Used with tools from KA-7485K
- Contains:
 - A. Plastic Box
 - B. York Seal Remover & Installer
 - C. Sanden 505 Seal Seat Remover
 - D. Sanden 505 Bearing & Pulley Installer
 - E. Sanden 505 Seal Protector Sleeve
 - F. Pulley & Clutch Remover Jaws
 - G. Shaft Protector Pilot



KA-7498K

FORD FS6, CHRYSLER C171, Nippondenso 6P 148A, Tecumseh HR-980 Seal Set

All specialized tools needed when replacing seals on the above compressors.



KA-7499K HITACHI & MITSUBISHI Seal Set

- Includes all tools necessary to replace seal on Hitachi MJS 123, 130, 157, 170, MJ 167, SWP 167 and Mitsubishi SA 430, SA 439.
- Used with tools from KA-7485K
- Contains:
 - A. Plastic Box
 - B. Diesel Kiki Nut Remover & Installer
 - C. Sankyo 505 Bearing & Pulley Installer
 - D. Mitsubishi Seal Seat Remover
 - E. Mitsubishi Seal Remover/Installer
 - F. Mitsubishi Seal Remover Lock Nut
 - G. Hitachi Spanner Plug Remover/Installer



KA-7500K
YORK/TECUMSEH, CHRYSLER RV-2 (TWO CYLINDER) Seal Set

All the specialized tools needed to replace seals on the above compressors.



KA-7583K SPECIAL GM DA6 SEAL SET

For carbon type seals used with tools from KA-7485K Set.

- KA-0165 Seal Remover & Installer
- KA-0170 Shaft Protector
- KA-0157 Clutch Plate Remover (Metric Thread)
- KA-0160 Clutch Plate Installer (Metric Thread)
- KA-0164 O-Ring & Snap-Ring Installer
- KA-0176 O-Ring Installation Guide



KA-7584K FORD FX-15/FS-10 Service Seal Set

This set consists of special tools needed to replace the seals on the FX-15/FS-10 compressor.

- KA-0183 Shaft Seal Remover
- KA-0184 Shaft Seal Installer
- KA-0185 Seal Protector(16 spline)
- KA-0186 Internal snap Ring Remover



KA-7585K Diesel KiKi service Seal Set

Includes all the tools necessary to service Diesel Kiki DKV14B, DKS-12B, DKS-15B, 13S, 15S and 17S compressors.

Used with tools from KA-7485K and KA-7568K sets:

- KA-0109** Diesel Kiki Drive Plate Installer
- KA-0118** Diesel Kiki Plate Remover
- KA-0128** Diesel Kiki Retainer Ring Installer
- KA-0109** Diesel Kiki Pulley Puller Pilot
- KA-0124** Diesel Kiki Seal Remover/Installer
- KA-0126** Diesel Kiki Seal Seat Remover/Installer



KA-7581K Universal Pulley Puller Set

- KA-0102 Puller Arbor
- KA-0186 Pulley Removal Jaws
- KA-0187 Set of Thumb Screws and Washers
- KA-0180 GM Pulley Removal Pilot
- KA-0179 Pulley Hub Removal Pilot
- KA-0132 Puller Body



KA-7582K Universal Clutch Pulley Puller

- KA-0178 Rotor and Bearing Pilot
- KA-0132 Universal Puller Body
- KA-0102 Universal Puller Arbor
- KA-0133 Universal Remover Jaws

**KA-7489 Ceramic & Steel Seat Remover & Installer****KA-7488 Steel Seal Seat Remover & Installer****KA-7537 Steel Seal Seat Remover & Installer****KA-7540 Hose Pinchers**

A QUICK, EASY WAY TO PINCH-OFF VACUUM LINES, FUEL LINES, AND OTHER HOSES. PREVENTS LEAKAGE, AND WON'T DAMAGE HOSES.

**KA-7541 R134 Low Side Octagon Socket - Japanese Standard**
KA-7541A R134 High Side Octagon Socket - Japanese Standard**KA-7542 R134a Service Port Reamer**

Deburs and chamfers R134a service ports in one easy motion. Eliminates burrs which can nick or cut coupler O-rings and cause couplers to leak.

**KA-7544 R12 Service Port Thread Repair Tool**

R12 service port thread restorer R12 1/4", 3/16" and 1/8" threads- a must to ensure R134a retrofit adaptors fit securely.

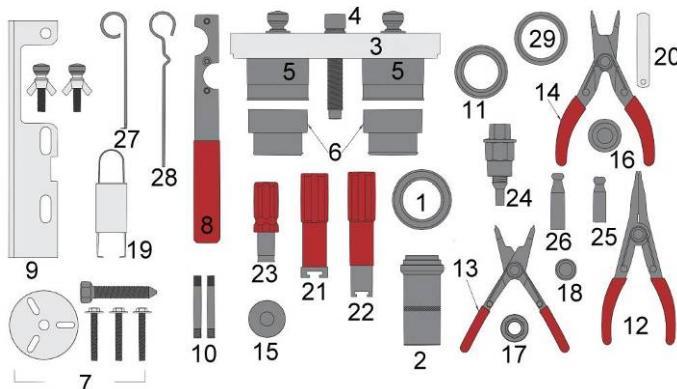

KA-7560K Master Sanden Compressor Tool Service Set

All specialized tools necessary to service seal, clutch and clutch bearing on Sanden 505, 507, 508, 510 and 575. Complete with H/D blow case and instructions.

Contains:

- | | |
|---|--|
| 1. KA-0110 bearing & pulley installer | 16. KA-0147 shaft protector pilot |
| 2. KA-0114 pulley bearing remover/drive | 17. KA-0148 seal retainer remover/installer |
| 3. KA-0132 puller body | 18. KA-0129 clutch plate installer |
| 4. KA-0102 puller arbor | 19. KA-0137 seal seat remover |
| 5. KA-0141 pulley & clutch remover jaws | 20. KA-0101 feeler gauge set |
| 6. KA-0142 pulley & clutch remover jaws | 21. KA-0125 seal remover/installer |
| 7. KA-0106 clutch plate remover | 22. KA-0123 YORK seal remover/installer |
| 8. KA-0143 clutch holder | 23. KA-0127 SANDEN 505 seal seat remover |
| 9. KA-0144 holding fixture & hardware | 24. KA-0119 clutch plate installer |
| 10. KA-0145 pilot studs | 25. KA-0121 SANDEN 505 seal protector sleeve |
| 11. KA-0111 SANDEN 505 bearing & pulley installer | 26. KA-0120 seal protector sleeve |
| 12. KA-0136 external retainer remover/installer | 27. KA-0138 O-ring seal sleeve remover |
| 13. KA-0135 internal snap ring plier | 28. KA-0148 oil level checker |
| 14. KA-0134 internal snap ring plier | 29. KA-0128 diesel kiki clutch installer |
| 15. KA-0146 clutch installer pilot | |

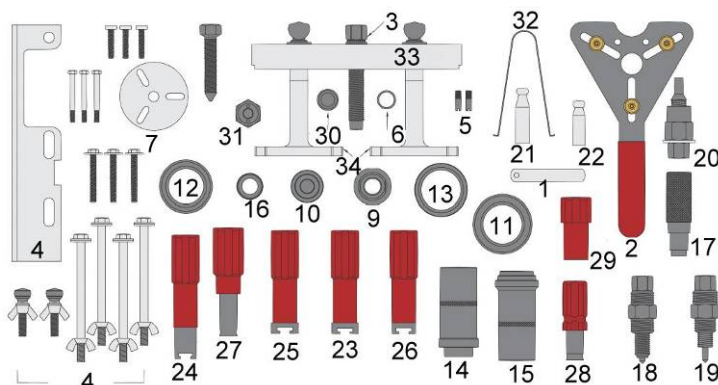
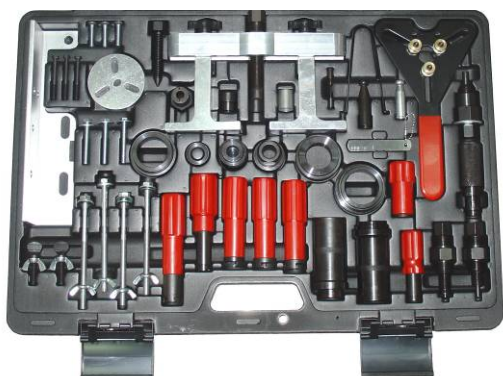

KA-7561K Master Import Compressor Clutch, Seal And Bearing Service Tool Set

Includes all the tools necessary to replace seals, clutches and clutch bearing on Diesel Kiki (Zexel), Hitachi, Mitsubishi, Nippondenso, Seiko-Seiki and Sanden 505, 507, 508, 510, 575, 708 and 709. Set is packaged into a heavy blow case. Set includes instruction manual.

Contains:

- | | |
|---|--|
| 1. KA-0101 universal feeler gauge set | 19. KA-0118 diesel kiki clutch plate remover |
| 2. KA-5010 universal clutch holding tool | 20. KA-0119 SANDEN plate installer |
| 3. KA-0102 pulley arbor | 21. KA-0120 seal protector sleeve |
| 4. KA-0103 compressor holding fixture | 22. KA-0121 SANDEN 505 seal protector sleeve |
| 5. KA-0104 clutch puller thrust pin | 23. KA-0122 MITSUBISHI seal remover & installer |
| 6. KA-0105 MITSUBISHI seal remover lock sleeve | 24. KA-0123 YORK seal remover & installer |
| 7. KA-0106 MITSUBISHI/SANDEN clutch plate remover | 25. KA-0124 seal remover & installer |
| 9. KA-0108 diesel kiki nut remover | 26. KA-0125 diesel kiki seal remover & installer |
| 10. KA-0109 pulley puller pilot | 27. KA-0126 seal seat remover & installer |
| 11. KA-0110 bearing & pulley installer | 28. KA-0127 SANDEN 505 SEAL SEAT REMOVER |
| 12. KA-0111 SANDEN 505 bearing & pulley installer | 29. KA-0128 diesel kiki retainer ring installer |
| 13. KA-0112 bearing & pulley installer | 30. KA-0129 CLUTCH PLATE INSTALLER |
| 14. KA-0113 diesel kiki pulley drive | 31. KA-0130 HITACHI spanner plug remover & installer |
| 15. KA-0114 pulley bearing remover & installer | 32. KA-0131 MITSUBISHI seal seat remover |
| 16. KA-0115 seal seat installer | 33. KA-0132 puller body |
| 17. KA-0116 seal seat remover | 34. KA-0133 pulley remover jaws |
| 18. KA-0117 NIPPONDENSO clutch plate | |

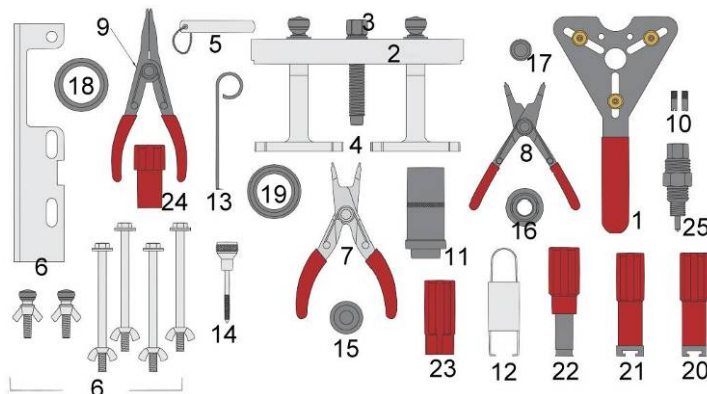

KA-7562K Diesel Kiki (Zexel) Seal And Clutch Tool Set

Servises standard Diesel Kiki and York compressor models DKS 12 and DKS 15. Complete with H/D blow case and instructions.

Contains:

- | | | | |
|-------------|-------------------------------|-------------|----------------------------------|
| 1. KA-5010 | universal clutch holding tool | 14. KA-0139 | vale plate remover |
| 2. KA-0132 | universal puller body | 15. KA-0109 | pulley puller pilot |
| 3. KA-0102 | pulley puller arbor | 16. KA-0108 | lock nut remover & installer |
| 4. KA-0133 | pulley remover jaws | 17. KA-0129 | clutch plate installer |
| 5. KA-0101 | universal feeler gauge set | 18. KA-0107 | 6" clutch bearing installer |
| 6. KA-0103 | compressor holding fixture | 19. KA-0111 | bearing & pulley installer |
| 7. KA-0134 | internal snap-ring plier | 20. KA-0125 | seal remover & installer |
| 8. KA-0135 | internal snap-ring plier | 21. KA-0124 | seal remover & installer |
| 9. KA-0136 | external snap-ring plier | 22. KA-0126 | seal remover & installer |
| 10. KA-0104 | clutch puller thrust pin | 23. KA-0140 | seal seat installer |
| 11. KA-0113 | pulley bearing driver | 24. KA-0128 | snapOring, o-ring felt installer |
| 12. KA-0137 | seal seat remover | 25. KA-0118 | clutch plate remover |
| 13. KA-0138 | O-ring sleeve remover | | |

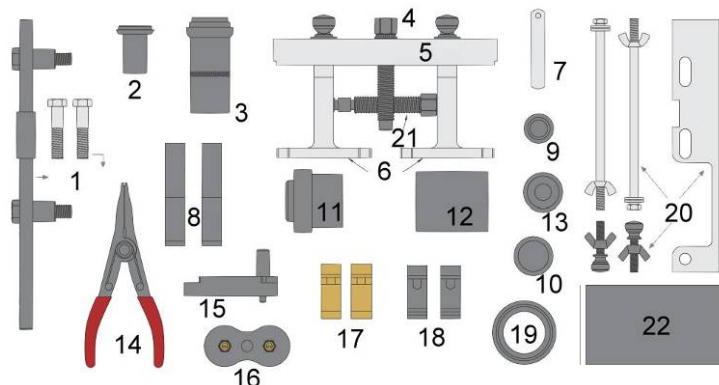
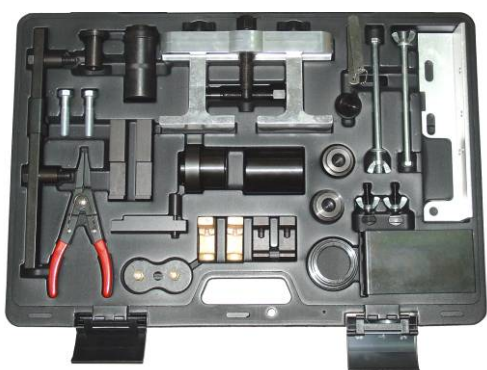

KA-7578K Master Clutch Service Tool Set

The Set contains all the tools needed to service clutches on the following compressors:

General Motors A6, R4, and DA6; 6 Pole R4, V5 and HR-6; Ford FS6; Chrysler C171; Nippondenso 6P 148A; Sanden 507, 508 and 510 and Pitts and Warner clutches.

All in H/D blow case

Contains:

- | | | | |
|-------------|---------------------------------------|-------------|--------------------------------|
| 1. KA-0177 | compressor holding fixture & hardware | 12. KA-0183 | coil installer |
| 2. KA-0178 | rotor & bearing pilot | 13. KA-0156 | shaft protector pilot |
| 3. KA-0114 | pulley bearing remover & driver | 14. KA-0136 | external retaining ring pliers |
| 4. KA-0102 | pulley arbor | 15. KA-0184 | clutch bearing staking tool |
| 5. KA-0132 | puller body | 16. KA-0185 | GM compressor test plate |
| 6. KA-0133 | pulley remover jaws | 17. KA-0186 | rotor & bearing puller jaws |
| 7. KA-0101 | feeler gauge set | 18. KA-0187 | pulley removal jaws |
| 8. KA-0179 | coil puller jaws | 19. KA-0110 | bearing & pulley installer |
| 9. KA-0180 | pulley hub removal pilot | 20. KA-0188 | compressor holding fixture set |
| 10. KA-0181 | pulley removal pilot | 21. KA-0189 | universal puller arbor |
| 11. KA-0182 | clutch assembly installer | 22. KA-0190 | rotor & bearing puller arbor |

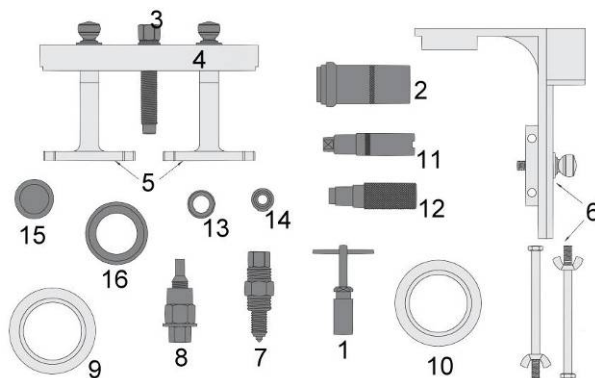

KA-7579K NIPPONDENSO Service Set

Contains all the specialized tools required to service Nippondenso type compressors appearing on many Ford, Chrysler and imported vehicles. Includes a special holding fixture for cross bolt mount configuration. Complete with blow case and instructions.

Contains:

- | | | | |
|------------|---------------------------------|-------------|-------------------------------|
| 1. KA-0150 | valve plate remover | 9. KA-0152 | clutch pulley support |
| 2. KA-0114 | pulley bearing remover & driver | 10. KA-0153 | WARNER clutch pulley support |
| 3. KA-0102 | universal pulley puller arbor | 11. KA-0154 | shaft key remover |
| 4. KA-0132 | universal puller body | 12. KA-0116 | seal seat remover |
| 5. KA-0133 | pulley removal jaws | 13. KA-0115 | seal seat installer |
| 6. KA-0151 | compressor holding fixture | 14. KA-0155 | shaft key installer |
| 7. KA-0118 | clutch plate remover | 15. KA-0156 | shaft protector pilot (small) |
| 8. KA-0119 | clutch plate installer | 16. KA-0110 | bearing & pulley installer |

- For complete Ford FS-6 service: this set must be used with:
KA-0136 external snap-ring pliers
KA-5010 universal clutch holding tool
- For complete Ford 10PA17, service set KA-7579K must be used with KA-7482K

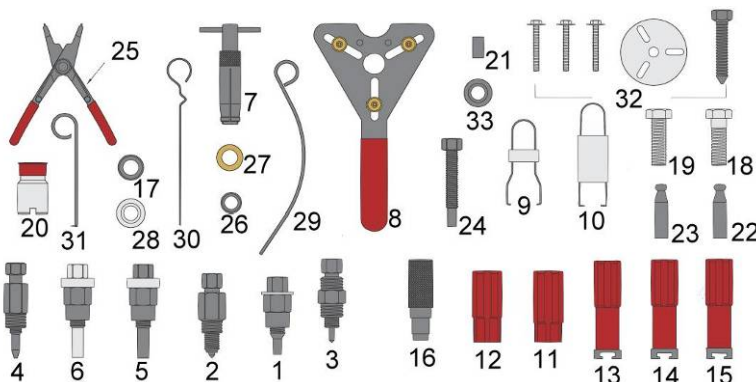

KA-7580K Master Seal Service Tool Set

The set includes all the tools from KA-7485K, KA-7498K, KA-7500K, KA-7483K and KA-7583K in a H/D blow case.

Easy to understand instruction manual will show you step-by-step how to service all the popular compressors.

Contains:

- | | | | |
|-------------|---------------------------------------|-------------|------------------------------------|
| 1. KA-0119 | clutch plate installer | 18. KA-0167 | 5/8"x2"x18 SAE clutch remover |
| 2. KA-0157 | clutch plate remover | 19. KA-0168 | 5/8"x2"x11 NC clutch remover |
| 3. KA-0158 | clutch plate remover | 20. KA-0169 | seal installer & plate alignment |
| 4. KA-0159 | clutch plate remover | 21. KA-0170 | shaft protector |
| 5. KA-0160 | clutch plate installer | 22. KA-0120 | seal protector sleeve |
| 6. KA-0161 | clutch plate installer | 23. KA-0171 | seal protector |
| 7. KA-0162 | ceramic seal seat remover & installer | 24. KA-0172 | clutch plate remover arbor |
| 8. KA-5010 | universal clutch holding tool | 25. KA-0135 | internal snap ring pliers |
| 9. KA-0163 | seal remover | 26. KA-0129 | clutch plate installer |
| 10. KA-0137 | seal seat remover | 27. KA-0173 | O-ring installation guide |
| 11. KA-0140 | seal seat installer | 28. KA-0174 | O-ring installation guide |
| 12. KA-0164 | O-ring snap-ring installer | 29. KA-0175 | YORK & TECHMSEH oil level dipstick |
| 13. KA-0123 | seal remover & installer | 30. KA-0149 | CHRYSLER oil level dipstick |
| 14. KA-0165 | seal remover & installer | 31. KA-0138 | O-ring seal sleeve remover |
| 15. KA-0166 | seal remover & installer | 32. KA-0106 | clutch plate puller |
| 16. KA-0116 | seal seat remover | 33. KA-0176 | O-ring installation guide |
| 17. KA-0115 | seal seat installer | | |



KA-7563K Safety A/C Adapter Set

Various hose end shut-off valves, flex adapters and replacement gaskets, valve cores and depressors. Includes popular hose end adapters:

- A 1/4" x 1/4" shut-off
- B 1/4" x 3/16" shut-off
- C GM 1991 & later service adapter
- D 1/4" x 3/16" GM flex
- E 1/4" x 1/8" Ford flex
- F Misc. gaskets, valve cores, depressors



KA-7564K 5pcs Auto A/C Swivel Adapters Set

- Replace clutches found on FS6, C171, 6P & 148 compressor.
- Also GM R4 & A6, HR-6, DA-6 & V5 A/C compressors.
- And compressors of Sanden SD505, 507, 508, 510, 575, 708 and 709.
- 2 & 3 hole puller plate fits most clutches, the mechanical force does the pulling job.
- Hose: 3/16" x 1/4" & 1/8" x 1/4"
- 90° shut-off 10 x 1/4", 11 x 3/16", 12 x 1/8"



KA-7565K Popular Adapter Set

Includes popular hose-end adapters:

- A 1/4" x 1/4" shut-off
- B 1/4" x 3/16" shut-off
- C GM 1991 & later service adapter
- D 1/4" x 1/8" 90° shut-off (Ford high side)
- E 1/4" x 3/16" 90° shut-off
- F Ford quick disconnect
- G GM large bore quick disconnect



KA-7567K Universal A/C Adapter Set

Adapter set includes hose end shut-off valves, flex adapters, GM and Ford quick disconnects.

Includes:

- A 1/4" x 1/4" shut-off
- B 1/4" x 3/16" shut-off
- C GM 1991 & later service adapter
- D 1/4" x 3/16" GM flex
- E 1/4" x 1/8" Ford flex
- F Ford quick disconnect
- G GM and Ford quick disconnect
- I GM large bore quick disconnect



KA-7568 Auto Quick Coupler Set For R134a

High pressure & low pressure quick couplers with 14mm female thread.

KA-7569 Quick Coupler

High pressure quick coupler with 14mm female thread.

KA-7570 Quick Coupler

Low pressure quick coupler with 14mm female thread.



KA-7571 Adapter

- Quick coupler W/straight adapter 10x1.5, 7/16"x20T, 1/2"x16T
- For R-12 & R134a



KA-7572 Quick Coupler

High pressure & low pressure quick couplers fitted with hose thread.



KA-7573 Air Cock

- HI-SIDE ADAPTOR 3/8" -24F
- ALUM ADAPTOR 7/16"x20T - 3/8"x24T
- FOR GM



KA-7574 Quick Coupler

High pressure & low pressure quick couplers 90° fitted with 14mm female thread. Specially suitable for small charging space or any angle charging.



KA-7575 Quick Coupler

High pressure & low pressure quick couplers 90° fitted with 1/4" male flare hose thread. Specially suitable for small charging space or any angle charging.



KA-7576 Flex Adapter

For AUDI & VW



KA-7577K Flush Kit

Provides pressure flushing of condensers, evaporators, and refrigerant lines after the air conditioning system is completely discharged. Designed to work with any lightweight flushing material which can be mixed with pressurized air. Includes flush gun, hose, canister, and canister adaptor.



KA-2147 3-In-1 Side Mount Can Tap Valve

- New design charge cans covers: 2-7/8"(R134a), 2-1/2"(R12), 2"(oil)
- Handy tool punctures clean hole on side of air conditioning refrigerant can; may be used at either top or bottom of can.



KA-2892-2 2-in-1 Valve Core Tool For Cars

- 4.5MM & 4.6MM

KA-2892-3 2-in-1 Valve Core Tool For Trucks and Agrar Cars

- 4.5 MM & 7.5MM



KA-6315A 4-in-1 Valve Repair Tool

Removes and installs valve core, extracts damaged core, rethreads inside of stem, rethreads outer part of stem and can be used to install new stem in tubeless tires.



KA-7538 2pc Valve Core Remover & installer



KA-6145F R12/R134a Valve Core Remover & Installer

L: 68 x W: 19mm



KA-5509 R12/R134a Valve Core Remover & Installer

L:64 x W:16mm



KA-9005 Tire Valve Core Tool

5-1/2" L for remover & installer



KA-5529 Valve Core Remover & Installer

- L: 140mm(5-1/2") x W: 13mm(1/2")
- For easy installation and removal of valve cores.
- 2 slotted valve core tools on both ends, one end for large bore, one end for standard sizes.



KA-5510 H/D Valve Core Remover & Installer

L: 135 x W: 30mm



KA-5529A Tire Valve Core Tool

- Slotted end for easy installation and removal of valve cores.
- Tapered end has threads to extract broken valve core.



R-134a Aluminum Manifold Gauge With Sight Glass

2pcs adjustable quick couplers **KA-7572**

1/4" SAE connection

- KA-7392A** with 3pcs 36" hose
- KA-7392B** with 3pcs 60" hose
- KA-7392C** with 3pcs 72" hose

2pcs quick couplers S **KA-7568**

1/2" ACME connection

- KA-7393A** with 3pcs 36" hose
- KA-7393B** with 3pcs 60" hose
- KA-7393C** with 3pcs 72" hose



R-134a Aluminum Manifold Gauge With Sight Glass

2pcs adjustable quick couplers **KA-7572**

1/4" SAE connection

- KA-7394A** with 3pcs 36" hose
- KA-7394B** with 3pcs 60" hose
- KA-7394C** with 3pcs 72" hose

2pcs quick couplers S **KA-7568**

1/4" ACME connection

- KA-7395A** with 3pcs 36" hose
- KA-7395B** with 3pcs 60" hose
- KA-7395C** with 3pcs 72" hose



R12 Testing Manifold Set

Sight glass brass testing manifold body with hook and two wheel handles.

R-12 BRASS MANIFOLD GAUGE WITH SIGHT GLASS

2pcs adjustable quick couplers **KA-7572**

1/4" SAE connection for R12

- KA-7397A** with 3pcs 36" hose
- KA-7397B** with 3pcs 60" hose
- KA-7397C** with 3pcs 72" hose

2pcs quick couplers S **KA-7568**

1/4" ACME connection

- KA-7397D** with 3pcs 36" hose
- KA-7397E** with 3pcs 60" hose
- KA-7397F** with 3pcs 72" hose



R-12 Brass Manifold Gauge With Sight Glass

2pcs adjustable quick couplers **KA-7572**

1/4" SAE connection for R12

- KA-7398A** with 3pcs 36" hose
- KA-7398B** with 3pcs 60" hose
- KA-7398C** with 3pcs 72" hose

2pcs quick couplers S **KA-7568**

1/4" ACME connection

- KA-7398D** with 3pcs 36" hose
- KA-7398E** with 3pcs 60" hose
- KA-7398F** with 3pcs 72" hose



KA-7404H Gauge
 pc cover high side
 0 to 500 psi
 1/8" NPT connection 2-3/4" dia, red color
 scale for R134a & R12



KA-7404L Gauge
 pc cover high side
 30 vacuum to 250 psi 1/8" npt connection 2-3/4"
 dia, blue color
 scale for R134a & R12



KA-7405H Gauge
 pc cover high side
 0 to 500 psi
 1/8" NPT connection 2-3/4" dia
 scale for R134a & R12



KA-7405L Gauge
 pc cover low side
 30 to 250 psi (vacuum)
 1/8" NPT connection 2-3/4" dia
 scale for R134a & R12



KA-7406H Gauge
 pc cover high side
 0 to 500 psi
 1/8" NPT connection 2-3/4" dia
 scale for R134a & R12



KA-7406L Gauge
 pc cover low side
 30 to 250 psi (vacuum)
 1/8" NPT connection 2-3/4" dia
 scale for R134a & R12



Single Manifold
KA-7403H high gauge
KA-7403L low gauge



KA-7407 Canvalve



KA-7408 Canvalve



KA-7417 Canvalve



KA-7415 One Way Valve



KA-7416 Canvalve



KA-7410 Hose



KA-7411 Canvalve Hose



KA-7414
Canvalve Hose



KA-7413
Canvalve Kit With Quick Coupler



KA-7412 Canvalve Kit



KA-7418
Hose Seal Gasket



KA-7419
Hose Seal Gasket



KA-6143K Master A/C Charging Adapter Repair Kit

126 piece assortment of replacement gaskets, o-rings and depressors for charging hoses and adapters. Also includes valve core removal tool and replacement valve cores.

Consists of:

KA-6143A	1/4" Gasket (20 pcs)	KA-6143F	1/4" Depressor (20 pcs)
KA-6143B	3/16" Depressor (20 pcs)	KA-6143G	3/16" Gasket (20 pcs)
KA-6143C	1/8" O-ring (20 pcs)	KA-6143H	Quick Disconnect Gasket (20 pcs)
KA-6143D	Refrigeration valve core (10 pcs)	KA-6143I	GM Large bore valve core (5 pcs)
KA-6143E	Universal valve core remover		



KA-6145K R12/R134a Valve Core Repair Kit

Replacement valve cores for valve core removers & installers

Consists of:

KA-6145A	Access valve core (20 pcs)	KA-6145D	GM Large bore valve core (10 pcs)
KA-6145B	R134a JRA high/low import Valve core (10 pcs)	KA-6145E	R134a domestic high flow Valve core M8 (5 pcs)
KA-6145C	R134a domestic high flow Valve core M10 (5 pcs)	KA-6145F	R12/R134a valve core Remover/installer (1 pcs)



KA-7431 Valve Core Remover/Installer

Sturdy ball valve design controls refrigerant flow with 1/4 turn of the valve lever. Lever position also gives visual indication of whether valve is opened or closed.



KA-4410A

KA-4410B

KA-4410A Valve Cores R-12

KA-4410B Valve Cores R-134a



KA-7434 Steel Body Clamp Can Tap Valve



KA-6133K 90° Manual Shut-Off Valve Set

Includes:

- KA-6133A** Blue hose 1/4"x1/4"
- KA-6133B** Yellow hose 1/4"x1/4"
- KA-6133C** Red hose 1/4"x1/4"

also available:

- KA-6134** Red hose 1/4"x3/16" (Automotive)

Straight Manual Shut-Off Valve Set



- KA-6138K** includes:
- KA-6138A** Blue hose 1/4"x1/4"
 - KA-6138B** Yellow hose 1/4"x1/4"
 - KA-6138C** Red hose 1/4"x1/4"

- KA-6139K** includes:
- KA-6139A** Blue 1/2" - 20 UNF-MxF
 - KA-6139B** Yellow 1/2" - 20 UNF-MxF
 - KA-6139C** Red 1/2" - 20 UNF-MxF

also available:

- KA-6140A** Red hose 1/4"x3/16" (Automotive)
- KA-6140B** Yellow hose 1/2" ACME x 1/2" ACME
- KA-6140C** Yellow hose M10 x 1.5-M x F

Japanese Standard



Manual Shut-Off Ball Valve

- KA-6141** 1/4"x1/4" swivel ball valve (less hose)
- KA-6142** 1/2" ACME x 1/2" ACME R134a ball valve (automotive, less hose)



Charging Hose For R134a

1/2" ACME connection, 14mmx 1/2" ACME

- KA-7400A** with 3pcs 36" hose
- KA-7400B** with 3pcs 60" hose
- KA-7400C** with 3pcs 72" hose



Charging Hose For R134a

1/4" SEA connection

- KA-7401A** with 3pcs 36" hose
- KA-7401B** with 3pcs 60" hose
- KA-7401C** with 3pcs 72" hose



KA-7402 Charging Hose For R12

1/4" SAE connection

Contents:

- KA-7402A** with 3pcs 36" hose
- KA-7402B** with 3pcs 60" hose
- KA-7402C** with 3pcs 72" hose

Charging Hoses With Built-In Manual Shut-Off Valve

KA-6125K 3pcs/set- Japanese Standard

Contents:

- KA-6125A** 72" Blue hose 1/4"x1/4"
- KA-6125B** 72" Yellow hose 1/4"x1/4"
- KA-6125C** 72" Red hose 1/4"x1/4"

KA-6126K 3pcs/set

Contents:

- KA-6126A** 72" Blue 1/2" - 20 UNF-MxF
- KA-6126B** 72" Yellow 1/2" - 20 UNF-MxF
- KA-6126C** 72" Red 1/2" - 20 UNF-MxF

Standard And High Pressure Hoses With Manual Shut-Off Valve Fittings (1/4" SAE)

Standard Hoses, Working Pressure 750 PSI, Burst 3000 PSI

HOSE LENGTH	36"	60"	72"
Blue 1/4	KA-6127A	KA-6128A	KA-6129A
Yellow	KA-6127B	KA-6128B	KA-6129B
Red	KA-6127C	KA-6128C	KA-6129C
Sets*	KA-6127K	KA-6128K	KA-6129K

Nylon Barrier Hoses, Working Pressure 800 PSI, Burst 4000 PSI

HOSE LENGTH	36"	60"	72"
Blue	KA-6130A	KA-6131A	KA-6132A
Yellow	KA-6130B	KA-6131B	KA-6132B
Red	KA-6130C	KA-6131C	KA-6132C
Sets*	KA-6130K	KA-6131K	KA-6132K



Oil Injectors

- Excellent method for adding refrigerant oil or large amounts of UV leak detection dyes to the a/c system.
- Quickly adaptable to manifold gauge sets or charging equipment. Add oil by allowing vacuum to pull it in after the evacuation process or use refrigerant to push it during the recharge process. Two ounce capacity.
- (R-134a model) 1/2" ACML Male x 13mm R134a Low side Female
- (R-12 model) 1/4 Flare Female x 1/4 Flare Male



KA-7425 R-12 1/4" SAE



KA-7426 R-134 1/2" ACME



KA-7427 R-12 1/4" SAE



KA-7428 R-134A 1/2" ACME



KA-7429 R-134A 1/2" ACME



KA-7430

Inject 1/4 to 1/2 ounce of fluorescent dye into R-12 or 134A A/C system under pressure



Easy Connect

KA-6160 13mm-Mxmm-F low side coupler (R134a)

KA-6161 1/4" FFL x 1/4" MFL



KA-7420 2 oz Air Condition Oil Injector

- Adds compressor oil to air conditioning systems
- Adaptor for R12 & R134a system
- Capacity: 2 oz

A. Concentrated dye scales

- 25 passenger vehicle applications:
- 1 application per 10oz (300ml) lubricant (AUTOMOTIVE)
- 1 application per 7lb (3.2kg) refrigerant (HVAC/R)

B. C Standard dye scales

- 8 passenger vehicle applications:
- 1/4 oz (7.5ml) per 10 oz (300ml) lubricant (AUTOMOTIVE)
- 1/4 oz (7.5ml) per 7lb. (3.2kg) refrigerant (HVAC/R)



KA-7420YP-C

A	25	24	23	22	21	20	19	18	17	16	15	14	13	12	11	10	9	8	7	6	5	4	3	2	1
B	1/4 oz		1/2 oz			3/4 oz			1 oz			1-1/4 oz			1-1/2 oz			1-3/4 oz			2 oz				
C	7.5 ML		15 ML			22.5 ML			30 ML			37.5 ML			45 ML			52.5 ML			60 ML				



Oil Injectors

KA-7432 for R-12

KA-7433 for R-134a



KA-5056Y
A/C Hose Remover Tools for Toyota

- For removing the A/C Hose Spring Lock Clamp of Toyota



KA-5056AY
A/C Hose Remover Tool – Simple Type for Toyota

- For removing the A/C Hose Spring Lock Clamp of Toyota



KA-5056BY
2pcs A/C Hose Clamping Tools

- 3/8"(S) & 5/8"(M)

1. SETTING

Confirm the remover direction regarding to the direction indication.

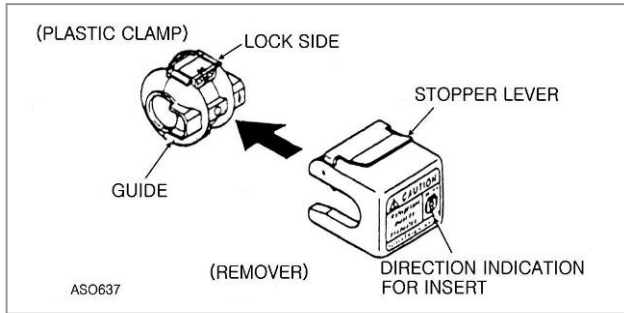

2. REMOVER ATTACHMENT

Attach the remover to the plastic clamp.

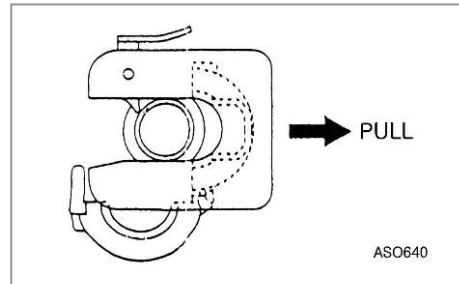

3. RELEASING CLAMP LOCK

Push the remover with thumbs then the clamp lock becomes released.

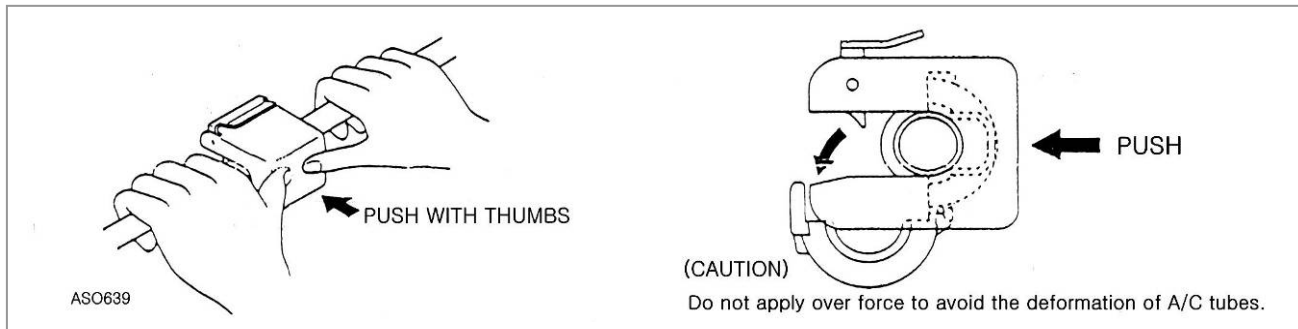

4. CLAMP SEPARATION

Pull the remover to separate the plastic clamp and tubes.

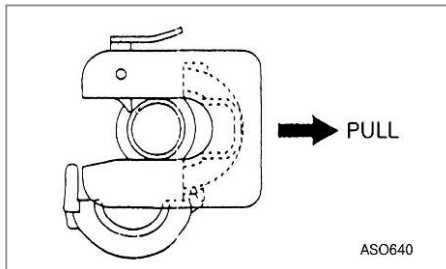

5. REMOVER PULL OUT

Operate the stopper lever and pull out the remover from A/C tubes.

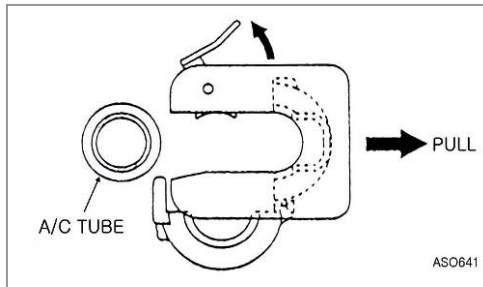

6. CLAMP REMOVAL

Pull out the plastic clamp from the remover.

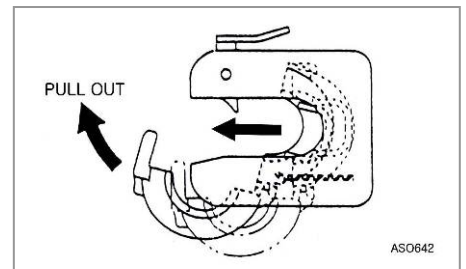

- Cautions :
- Refrigerant must be evacuated before using the remover.
 - Removing the plastic clamp filled with refrigerant may cause frostbite and eye blind.
 - Remover must be keep away from engine coolant and battery electrolyte.

Note : Do not bend the needles while removing the plastic clamp from remover.
 Deformation of needles may cause the difficult operation for releasing the clamp lock.



KA-6973K 12pcs Quick Fluid Stopper Set

- Quickly stop fluid from the separated fuel hoses.
- Available for injection hose or fuel supply hose adaptors.

Parts	Description	Operation
	<p>Extension Hose Clamp Material: Aluminum, Axle material: S45C Length: 310mm, Application size: 25.4mm Qty: 1pc</p>	
	<p>For Injection Hose Material: Nylon66 L: 82mm, W: 24mm, Stop ball size: Ø 18mm Qty: 2pcs</p>	
	<p>For Fuel Supply Adaptors Material: Nylon66 L: 82mm, W: 24mm, Stop ball size: Ø 10.4mm Concave size: L-13.6mm, W-8.3mm Qty: 2pcs</p>	
	<p>For Other Fuel Hoses L: 40mm Handle width: 14mm Head size: For 3/16" hose (2pcs) For 1/4" hose (2pcs) For 5/16" hose (2pcs)</p>	
	<p>Fuel Pipe Separator Material: Nylon66 L: 63mm, W: 22mm Concave size: Ø 8.8, Concave depth: 14mm Qty: 1pc</p>	



KA-5186A Quick Fluid Stopper Set

- Prevent fluid leaks and contamination during service.
- Quickly stop fluid from the separated fuel hoses.
- Use with all automotive fluids.
- Include:
 - (1) Steel line stopper
 3positions adjustable installs in seconds.
 Changeable rubber plugs (10.4 & 18mm)
 Kit includes: 5/16", 3/8", 1/2", Banjo
 - (2) Fuel hose stopper
 Kit includes: 1/8", 3/16", 1/4", 5/16", 3/8", 1/2"
 - (3) Extension hose clamp
 Application range: 1"
 - (4) Line disconnect tool
 KA-1265A-1: 1/2"
 KA-1265A-5: 5/16"
 KA-1265A-6: 3/8"

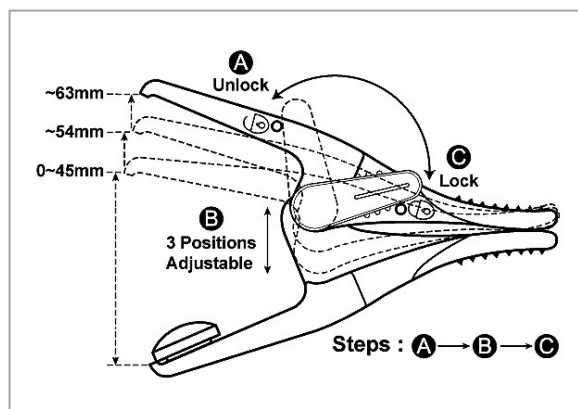



KA-5186 8pcs Steel Line Stopper Set

- Quickly stop fluid from the separated fuel hoses.
- Use with all automotive fluids
- Suitable for
 - Fuel rails and lines
 - Flare type steel brake, fuel & AC lines
 - Banjo fittings on brake, power steering & transmission cooler lines
- Contents:
 - 2pcs - 5/16"
 - 2pcs - 3/8"
 - 2pcs - 1/2"
 - 1pc - banjo(small)
 - 1pc - banjo(big)

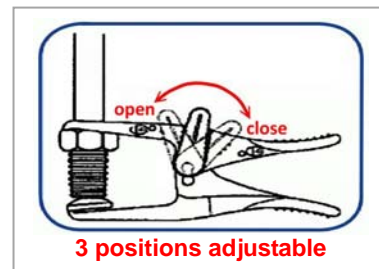

KA-5186-516
Steel line stopper 5/16"



KA-5186-38
Steel line stopper 3/8"



KA-5186-12
Steel line stopper 1/2"



KA-5186-BANJO
Suitable for Banjo fitting
Small & big

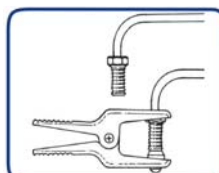

Flare Type Brake Line

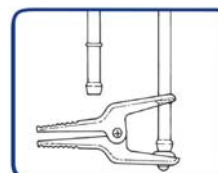

Fuel Line

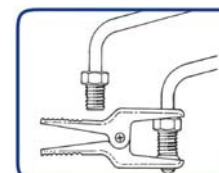

Flare Type Fuel Line

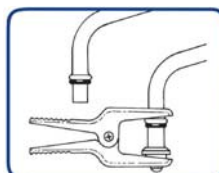

"O" Ring Type AC Line

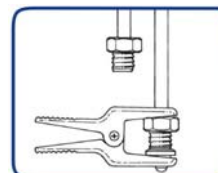

Flare Type AC Line

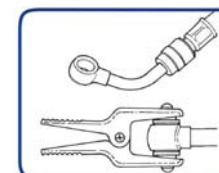

Banjo Fitting



KA-5194A Fuel Line Stopper Kit

- Ideal for sealing metal brake pipes.
- This suitable for clamping and sealing metal flared pipes on braking system, cooling system bypass, fuel pipes, AC pipes, etc.
- Also suitable for banjo pipe.
- Size: 4~6mm / 6~8mm / 8~10mm



Line Disconnect Tool for BMW

- Made of Red-Anodized Aluminum
- The new design of the BMW 5346 also covers the transmission cooler line.

KA-2158

Power steering and transmission line disconnect tool for 1999-2005 BMW 3-series and X5.

KA-2158A

Power steering and transmission line disconnect tool for 2006-2011 BMW 3-series and 2006-2009 X3(E90 & E83).



KA-5194 Steel Line Stopper Kit

- Use to seal steel lines once disconnected.
- Prevents fluid leaks and contamination during service.
- Use with all automotive fluids
- Suitable for
 - Fuel rails and lines
 - Flare type steel brake, fuel & AC lines
 - Banjo fittings on brake, power steering & transmission cooler lines
- Installs in seconds.



KA-7178 Coolant Filling Tool Set

- Quick and easy way to refill coolant during cooling system bleeding process.
- Quick, efficient and no mess.

Specification

Dimension: 160x160x260 m/m
 Weight: 450 gs
 K050: Black / Japanese Vehicles. American Vehicles
 K041: HONDA. TOYOTA
 K043: MITSUBISHI. FORD. NISSAN. MAZDA



KA-7250B Coolant Replacement System

- Synchronized operation, which sucks in waste coolant and supplies new coolant at exchange operation.
- Intake safety valve attached, automatically releases pressure while it is too high.
- "Engine Off" operation, back flush procedure to remove coolant and particulates efficiently on a hot or cold vehicle.
- Simple controls and quick coupler connection system make operation extremely fast, clean and easy.
- Simple connect to upper radiator hose with universal step adaptors.
 "Air Evacuation" operation to purge trapped air from cooling system to eliminate the possibility of engine damage due to overheating.

Model	KA-7250B
Dimension	480 x 650 x 1050 m/m
Capacity	20L
Weight	61.7 kgs



Air Line Disconnect Pliers

Disconnects the air line quick connector on heavy-duty vehicle air brake system.

KA-5264

- Easy loosening of air lines with diameters 6, 8, 10, 12mm
- Ideal for the straight air line quick connector.

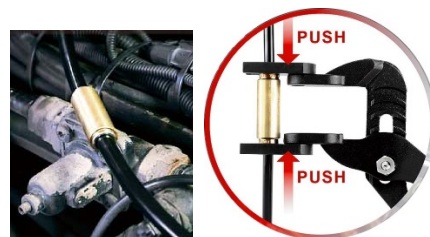

KA-5264A

- Easy loosening of air lines with diameters 6, 8, 10, 12, 15, 16mm
- Ideal for the elbow air line quick connector.



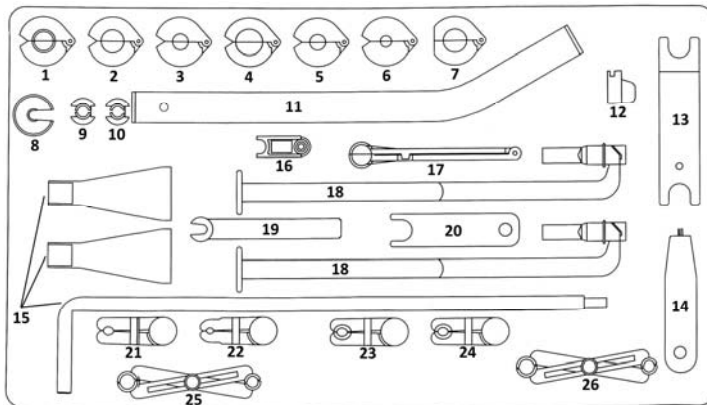

KA-6539KN Full Coverage Disconnect Coupling Set

All the tools required for disconnecting heater hoses, transmission oil cooler pipes, air conditioning pipes and fuel lines used on today's later model vehicles.

1	KA-216B Fuel Line Disconnect Tool- Green (1/2") Releases spring lock connector on 1/2" fuel line. 1987 & newer Ford vehicles w/spring lock connectors	2	KA-216A Fuel Line Disconnect Tool- Yellow (3/8") Releases spring lock connector on 3/8" fuel line. 1987 & newer Ford vehicles w/spring lock connectors.
3	KA-6494E A/C Spring Locking Coupling Tool- Red(3/8") Releases spring lock connector on 3/8" air conditioning line. 1981 & newer Ford vehicles, some 1994 & newer Chrysler vehicles	4	KA-6494B A/C Spring Locking Coupling Tool- Blue (1/2") Releases spring lock connector on 1/2" air conditioning line. 1981 & newer Ford vehicles, some 1994 & newer Chrysler vehicles
5	KA-6494C A/C Spring Locking Coupling Tool, Black(5/8") Releases spring lock connector on 5/8" air conditioning line.	5	KA-6494D A/C Spring Locking Coupling Tool- Beige(3/4") Releases spring lock connector on 3/4" air conditioning line. 1981 & newer Ford vehicles, some 1994 & newer Chrysler vehicles
7	KA-216E Ford Heater Hose Disconnect Tool Disconnects heater hose from engine. 1995 & newer Ford Drown Victoria & Mercury Grand Marquis w/4.6L engine	8	KA-6406A Ford/Gm Quick Disconnect Tool Releases quick connect fittings used on fuel, transmission, and power steering lines. Ford CF1 fuel ones w/ hair pin connectors; universal for radiator to transmission oil cooler lines 1987 & newer olds. Torondado; Buick Riviers & Reatta; Cadillac Eldorado, Seville, & Conncours 1989 & newer GM 1/2 ton, 3/4 ton & 1 ton pickups
9	KA-216D Fuel Line Disconnect Tool Releases quick connect on 3/8" fuel line. GM, Chrysler, & Ford vehicles w/ quick connect fuel lines.	10	KA-216C Fuel Line Disconnect Tool Releases quick connect on 5/16" fuel line. GM, Chrysler, & Ford vehicles w/ quick connector lines.
11	KA-216H Chrysler Fuel Line Disconnect Tool Releases quick connect fittings on fuel lines (pressure and return) 1994 & newer Chrysler LH vehicles, other Chrysler vehicles with quick connect fuel lines	11	KA-4337 GM Transmission Oil Cooler Line Disconnect Tool Specially designed to work in tight places, and so simple to operate you can do it with just one hand. After inserting into the quick-connect fitting, a quarter turn of the tool quickly and easily releases the fitting on the transmission end of the transmission-to-radiator oil cooler line. Works on 2WD and 4WD pickups and vans with electronic shift overdrive automatic transmission.
13	KA-6539K-P2 GM Hydraulic Clutch Line Disconnect Tool Damage-free way to reach and disconnect the clutch line from the slave cylinder during clutch master cylinder, slave cylinder, or clutch assembly service. Bentend works on NVG3500 manual transmissions on 1996 and newer full-size 2WD and 4WD trucks, S-10s, and S-15 Blazers/Jimmys. The quick connect fitting on the slave cylinder is recessed in the bell housing on these vehicles. The straight end is for 1993 and newer Pontiac Grand Prix, Olds Cutlass Supremes, Buick Regals; 1993-94 Chevy Lumias; and 1995 and newer Chevrolet Monte Carlos.	12	KA-6539K-P1 Toyota A/C Disconnect Tool Used to release the plastic quick-connect fittings on the high and low pressure air conditioning lines at the evaporator. Services 1998- newer Toyota Corolla, 1998- newer Geo Prism, 1998- 1/2- newer Toyota Land Cruiser and Lexus LX470, 1999- newer Toyota Avalon, Camry, Solara, and Sienna mini vans. Easy to use: Plastic fitting on A/C line is rotated to show access to the two release holes in the fitting, tool is inserted into release holes and pushed to release the fitting.
15	KA-216G Heater Hose Disconnect Tool -Chrysler & Ford Use tool to remove heater hose from heater core tube without damaging coupling, retainer or hose. It fits Ford 1986 to current Aerostar vans with 5/8" to 3/4" heater hoses and quick disconnect couplings. Its extension handle allows for easy access to coupling.	14	KA-5065 Ford Fuel Line Coupling Tool The best way to get easy, frustration - and damage-free fuel line separation. The tool's fingers slip into the fuel line coupling, depressing the retaining collar as they go. The tool works on 1990 and newer Ford Rangers and Explores having 4.0L, 6-cylinder engines.
17	KA-216F GM Heater Line Disconnect Tool Disconnects heater line from engine block / thermostat housing. Fits 1991-current GM 3.1 liter, 3.4 liter and 3.8 liter (3800) engine.	16	KA-216I Ford/Gm Fuel Line Disconnect Tool Set Releases quick connect fittings on 5/16" and 3/8" fuel lines.
19	KA-6406B Transmission Cooler Line and Fuel Line Quick Disconnect Tool Removes push lock connectors found at both the radiator and transmission. Used on 1983 through current Ford, and the 1982 Lincoln Continental overdrive transmissions. Tool slides down transmission cooler spread the plastic clip apart for easy removal.	17	KA-3009 Hydraulic Clutch Line Disconnect Tool For removing hydraulic clutch lines from clutch slave cylinders on some manual transmissions. Applications: 1989 to current Mercury Cougars & Thunderbirds. 1988 to current small trucks including; Explorer, Ranger & Bronco II.
21	KA-6677-14 Disconnect Tools - Black(1/4") Separates fittings on fuel lines, fuel filters & fuel tank return lines	18	KA-6677-516 Disconnect Tools - Red(5/16") Separates fittings on fuel lines, fuel filters & fuel tank return lines
23	KA-6677-38 Disconnect Tools - Yellow(3/8") Separates fittings on fuel lines, fuel filters & fuel tank return lines	19	KA-6677-12 Oil Cooler Line Disconnect Tool- Blue(1/2") Separates automatic transmission oil cooler lines on Ford Taurus and Escort with AXOD and ATX transmissions
25	KA-6410 Fuel Line Quick Disconnect Tool Tools service most type of quick-disconnect fittings used on Ford, GM & Chrysler vehicles. For easy fuel filter replacement 5/16" & 3/8".	20	KA-6409 Ford Fuel & A/C Line Spring Coupling Tool Releases locking mechanism on all four sizes of spring lock couplings on most Fords. Four separate sizes referenced 3/8", 1/2", 5/8" & 3/4".
		21	
		22	
		23	
		24	
		25	
		26	



KA-4109 Transmission Oil Cooler Line Disconnect For Ford

- Two sizes of 3/8" and 1/2" are designed to disconnect transmission cooler lines.
 - Simply push the line toward the connector, then engage tool and pull line from connector.
- Use 3/8" size for 2003 and later Ford V8 Explorer, 2004 and later Ford F150 and Cadillac vehicles
 - Use 1/2" size for Ford F250, F350 and F450 Super-Duty trucks

KA-5342 Mini Cooper Fuel Line Tool

The low pressure fuel feed line that supplies the high pressure fuel pump requires the special tool for removal. Failure to use this tool will result in damage to its quick connect coupler.



- Fits the following Mini Cooper S models with the N14 or N18 engine:
 - R55 (Cooper S / JCW Clubman) with the N14 / 18 engine - 2008-03/2012
 - R56 (Cooper S / JCW Hatch) with the N14 / 18 engine - 2007-03/2012
 - R57 (Cooper S / JCW Convertible) with the N14 / 18 engine - 2009-03/2012
 - R58 (Cooper S / JCW Coupe) with the N14 / 18 engine - 2012-03/2012
 - R59 (Cooper S / JCW Roadster) with the N14 / 18 engine - 2012-03/2012
 - R60 (Cooper S Countryman) with N18 engine - 2011-03/2012
- OEM Ref. 130250

NOTE: some (05/2010-2011) models, you need to loosen the 14mm flare nut on the fuel rail feed line and remove the lower 8mm fuel pump retaining bolt to use the tool.

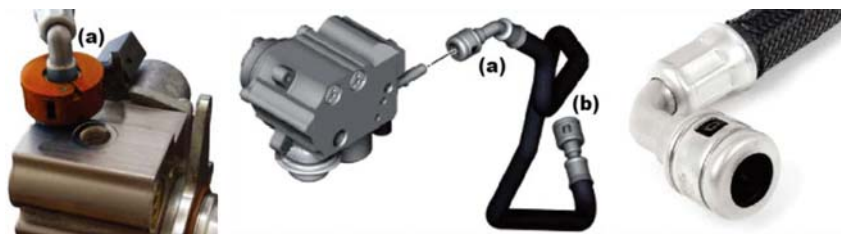

KA-5381 A/C Couplings Release Tool (VAG group)

- Releasing the quick-release connectors on the a/c lines.
- Suitable for VAG group (VW, Audi, Skoda, Seat):
 - Audi - A3 2004> ; A4 2001> ; 2008> ; A5 2008> ; Q5 2008> ; TT 2007>
 - Seat - Ibiza / Cordoba 93 ; Ibiza / Cordoba 99 ; Ibiza 02 / Cordoba 03 ; Ibiza 2008 ; Leon 2006 ; Leon 2009 ; Toledo / Leon 99 ; Toledo 2005 ; Alhambra ; Alhambra 2001 ; Altea 2005 ; Altea 2009 ; AlteaXL 2007 ; AlteaXL 2009 ; AlteaFreetrack 2007 ; AlteaFreetrack 2009 ; Exeo 2009 ; Arosa ; Inca
- OEM Ref. T40149

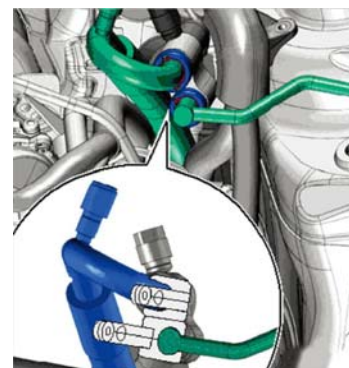

KA-5383 Fuel Line Disconnect Tool

- For Navistar International MaxxForce 11 and 13 engines.
- The straight tools allow access into tight area.
- OEM Ref. ZTSE4773 and ZTSE4772

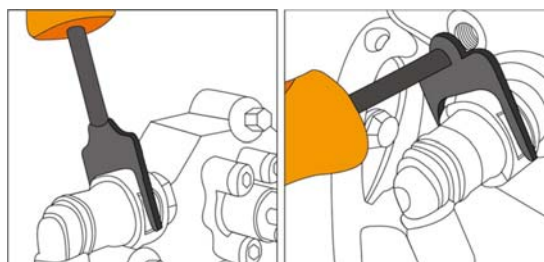

A/C Compressor Clutch Holding Tool (Ford-Europe)

- Hold the A/C clutch hub with the special tool.
- Remove the hub bolt and A/C clutch disc.
- 3/8" Dr.

<p>KA-4140A ■ OEM Ref. 412-157</p> 	<p>KA-4140B ■ OEM Ref. 412-154</p> 
<p>KA-4140C ■ OEM Ref. 412-103</p> 	<p>KA-4140D ■ OEM Ref. 412-134</p> 

KA-4140A (2.0L Panther L4 diesel engine)	
Transit	2013~
Transit Custom	2012~
KA-4140B (DV6 engine)	
C-MAX	2010~, 2015~
Fiesta	2017~
Focus	2010~, 2014~, 2018~
Ka+	2016~
Kuga	2012~
Transit/Tourneo Connect	2013~
Transit/Tourneo Courier	2013~
KA-4140C	
B-MAX	2012~
C-MAX	2010~, 2015~
Fiesta	2008~, 2012~
Focus	2010~
KA-4140D	
C-MAX	2010~, 2015~
Ecosport	2012~
Edge	2015~
Fiesta	2018~, 2012~, 2017~
Focus	2010~, 2014~, 2018~
Galaxy	2015~
Kuga	2012~
Mondeo	2014~
S-Max	2015~
Transit	2013~
Transit Custom	2013~
Transit/Tourneo Connect	2013~
Transit/Tourneo Courier	2013~

KA-3820 A/C Compressor Pulley Holding Tool For Ford

- A/C pump (compressor) holding tool.
- Applications Ford: Kuga (from 2012), S-Max (from 2015), Transit Courier (from 2013), C-Max (from 2010), B-Max (from 2012), Ecosport (from 2012), Edge (from 2015), Fiesta (from 2008), Focus (from 2010), Galaxy (from 2015).
- Required when changing the A/C pump or pulley.

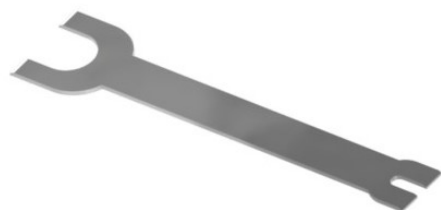
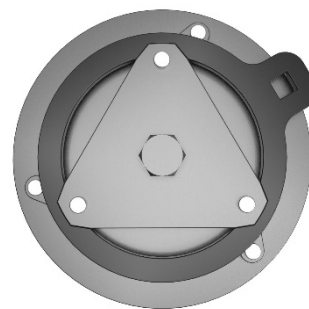

KA-4143 A/C Clamp Remover

- Fits both high and low edge clamps.
- Suitable chamfer opens clamps.
- For dismantling line clamps found on Toyota Tacoma (2015-2018).

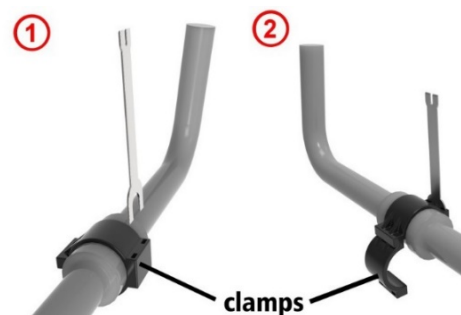

KA-7852 Diesel Fuel Line Disconnect Pliers

- Material: S45C Steel
- Handle: SPHC Steel
- The special pliers with 'V' shaped jaws releases the fuel line connection from the fuel filter fitted to diesel engines on most European vehicles.
- Spring loaded action enables the connection to be held securely when the fuel line is being disconnected.



KA-5264C Fuel & AC Line Disconnect Pliers

- The unique design gives extra leverage and allow the forks to have different sized of opening for disconnecting quick connect coupled AC and fuel lines.
- The tool can be flipped around for working on both single and two-step collar connector lines.
- The tool's extra length allow it to be used to reconnect stubborn lines or fittings in hard-to-reach areas.



KA-5383F Fuel Line release Tools for Servicing International Maxx Force Engine

- Specially made for servicing the International Maxx Force series 11 and 13 engines
- Heat-treated fork tines to eliminate tool deflection after use.
- Coating grip handles providing comfort while use.
- Straight type and Angled type.

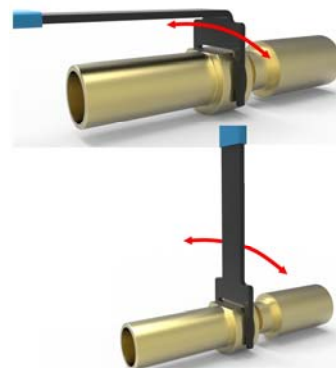

KA-6871 Fuel Line Puller

- Special size for removing the injector of high side adaptor.
- For Nissan and Toyota.
- Application:



Brand	Model	Year
Nissan	Altima	2004-2010
	Frontier	2005-2014
	Murano	2008-2014
	Sentra	2007-2017
	Titan	2004-2015
Toyota	Camry	2000+
	Celica	2000-2006
	Corolla	2000+
	Echo	2000-2005
	Highlander	2000+
	Matrix	2002-2014
	MR2	2000-2007
	Prius	2000+
	RAV4	2000+
	Sequoia	2000+
Solara	1999-2008	
Tundra	2000+	
Scion	tC	2004-2016
	xA	2004-2006
	xB	2008-2015

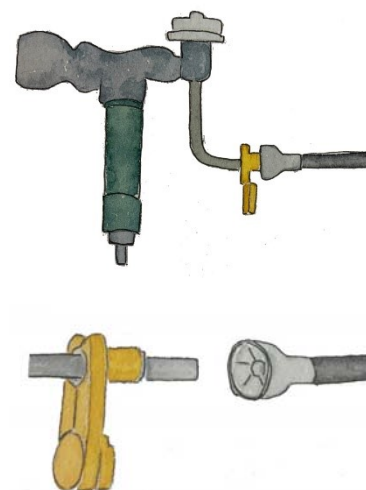

KA-3832 Air Line Disconnect Tool Kit

- Disconnects air lines even in hard-to-reach areas.
- Angled end/tip allows maximum leverage.
- Straight end fits in tight spots.
- Disconnects air systems on : Heavy-duty truck/brakes/suspension / steering / engine / transmission.
- Disconnects push-in connectors found on : Chemical / food processing / printing/ semiconductor / other auxiliary equipment.
- Also disconnects other push-in fittings, including : flow control valves / check valves / shuttle valves / quick exhaust valves /other function control fittings in compressed air systems.

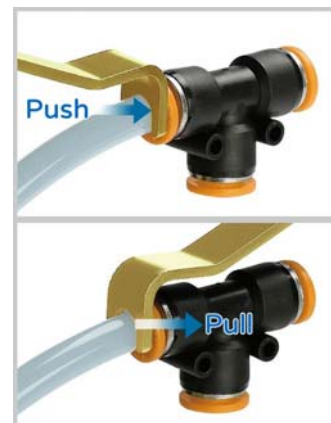

KA-5186S Steel Line Stopper Kit

- Spring loaded design to install quickly!
- Perfect for any automotive fluid line repairs: Brake, Transmission cooler line, A/C, Fuel...etc.
- Split the brake line without brake fluid leaking and splashing. Eliminate the brake fluid mess for work space.
- Plug the steel lines once disconnected. Smooth rounded edge does not cause damage to internal hose.
- Fit plug lines:
Banjo, 5/16", 3/8", 1/2".
- Packed in blow case.



KA-7043 Mini Tubing Cutter

ZINC BODY
ZINC KNOB
SUJ2 CUTTING WHEEL WITH SPECIAL HEAT-TREATED.
CAPACITY: 1/8" - 5/8" (3 - 16mm)



KA-7044 Mini Tubing Cutter

ZINC BODY
ZINC KNOB WITH SK-2 CUTTING WHEEL
CAPACITY: 1/8" - 5/8" (3 - 16mm)



KA-7045 Mini Tubing Cutter

ZINC BODY
IRON KNOB
SK2 CUTTING WHEEL
CAPACITY: 1/8" - 5/8" (3 - 16mm)



KA-7046 Mini Tubing Cutter

ZINC BODY.
IRON KNOB
SK2 CUTTING WHEEL
CAPACITY: 1/8" - 7/8" (3 - 22mm)



KA-7047 Mini Tubing Cutter

ZINC BODY.
IRON KNOB
SK2 CUTTING WHEEL
POLISHED ROLLER
CAPACITY: 1/8" - 7/8" (3 - 22mm)



KA-7048 Mini Tubing Cutter

ZINC BODY
ZINC KNOB
SK2 CUTTING WHEEL
CAPACITY: 1/8" - 7/8" (3 - 22mm)



KA-7049 Mini Tubing Cutter

ALUMINUM ALLOY DIE
CASTING BODY
CAPACITY: 3/8" - 1 1/8" (9 - 28mm)



KA-7050 Mini Tubing Cutter

ZINC BODY
ZINC KNOB WITH SPARE CUTTING WHEEL
SK2 CUTTING WHEEL
CAPACITY: 1/8" - 5/8" (3 - 16mm)



KA-7051 Mini Tubing Cutter

ZINC BODY
ZINC KNOB
SK2 CUTTING WHEEL
CAPACITY: 1/8" - 7/8" (3 - 22mm)



KA-7052 Mini Tubing Cutter

ZINC BODY
ZINC KNOB WITH DEBURRING BLADE
SK-2 CUTTING WHEEL
CAPACITY: 1/8" - 1-1/8" (3 - 28mm)



**KA-6838
Tubing Cutter**

ALUMINUM BODY
ZINC KNOB
SK2 CUTTING WHEEL
CAPACITY: 1/8" - 1 1/8"
(3 - 28mm)



**KA-7054
Tubing Cutter**

ALUMINUM BODY
ZINC KNOB
SK2 CUTTING WHEEL
CAPACITY: 1/8" - 1 1/8"
(3 - 28mm)



**KA-7055
Tubing Cutter**

ZINC BODY.
NYLON KNOB.
SK2 CUTTING WHEEL
SPARE CUTTING WHEEL ADDED
ON THE KNOB
POLISHED ROLLER
CAPACITY: 1/8" - 1 1/8"
(3 - 28mm)



**KA-6840
Tubing Cutter**

ZINC BODY
NYLON KNOB
SK2 CUTTING WHEEL
SPARE CUTTING WHEEL ADDED
ON THE KNOB
POLISHED ROLLER
CAPACITY: 1/8" - 1 1/8"
(3 - 28mm)



**KA-7057
Tubing Cutter**

ALUMINUM BODY.
NYLON KNOB
SK2 CUTTING WHEEL
CAPACITY: 1/8" - 1 1/8"
(3 - 28mm)



**KA-7058
Tubing Cutter**

ALUMINUM BODY.
NYLON KNOB
SK2 CUTTING WHEEL
CAPACITY: 1/8" - 1 1/8"
(3 - 28mm)



**KA-7059
Tubing Cutter**

ZINC BODY
ZINC KNOB
SK2 CUTTING WHEEL
CAPACITY: 1/8" - 1 1/8"
(3 - 28mm)



**KA-7060
Tubing Cutter**

ALUMINUM BODY
NYLON KNOB
QUICK RELEASE DEBURRING
BLADE
SK2 CUTTING WHEEL
CAPACITY: 1/8" - 1 1/2"
(3 - 38mm)



**KA-7061
Tubing Deburring Cutter**

FOR INSIDE & OUTSIDE
DEBURRING
ZINC BODY
SAE 1086 BLADE
FOR 1/8" - 1 5/8" O.D. TUBE



**KA-7062
Tube Deburring Cutter**

PLASTIC BODY
SK2 DEBURRING BLADE
CAPACITY: 4 - 38mm
(3/16" - 1 - 1 1/2")



KA-7063
Tubing Cutter

ALUMINUM ALLOY DIE CASTING
BODY
CAPACITY: 1/8" - 1 1/4"
(3 - 32mm)



KA-7064
Telescopic Tubing Cutter

ALUMINUM ALLOY DIE CASTING
BODY
CAPACITY: 3/16" - 1 3/4"
(5 - 45mm)



KA-7065
Tubing Cutter

ALUMINUM ALLOY DIE CASTING
BODY
SUJ-2 CUTTING WHEEL
RETRACTABLE DE-BURRING BLADE
CAPACITY: 1/4" - 1 1/2"
(6 - 38mm)



KA-7066
Zip Action Tubing Cutter

ALUMINUM ALLOY DIE CASTING
BODY
SUJ-2 CUTTING WHEEL
RETRACTABLE DE-BURRING
BLADE
CAPACITY: 3/16" - 1 1/4"
(4 - 32mm)



KA-7067
Telescopic Tubing Cutter

ALUMINUM BODY.
ZINC KNOB
SPARE CUTTING WHEEL
INCLUDED.
SK2 CUTTING WHEEL
POLISHED ROLLER
CAPACITY: 1/8" - 1 1/4"
(3 - 32mm)



KA-7068
Telescopic Tubing Cutter

ALUMINUM BODY.
ZINC KNOB
SUJ2 CUTTING WHEEL WITH
SPECIAL HEAT-TREATED.
SPARE CUTTING WHEEL
INCLUDED.
CAPACITY: 1/4" - 1 5/8"
(6 - 42mm)



KA-7069
Telescopic Tubing Cutter

ALUMINUM BODY
ALUMINUM KNOB
SUJ2 CUTTING WHEEL WITH
SPECIAL HEAT-TREATED.
SPARE CUTTING WHEEL INCLUDED
CAPACITY: 1/8" - 1 1/8"
(3 - 28mm)



KA-6839
Tubing Cutter

ALUMINUM BODY
ZINC KNOB
SUJ2 CUTTING WHEEL WITH
SPECIAL HEAT-TREATED
SPARE CUTTING WHEEL
INCLUDED
CAPACITY: 1/8" - 1 1/8"
(3 - 28mm)



KA-7071
Zip Action Tubing Cutter

ALUMINUM ALLOY DIE
CASTING BODY
CAPACITY: 1/4" - 2"
(6 - 50mm)



KA-7072
Zip Action Tubing Cutter

ALUMINUM ALLOY DIE
CASTING BODY
CAPACITY: 1/4" - 2 5/8"
(6 - 67mm)



KA-7073

Tubing Cutter

ALUMINUM ALLOY DIE CASTING BODY
ZINC KNOB WITH DEBURRING BLADE
SK-2 CUTTING WHEEL
CAPACITY: 1/8" - 1 1/8"
(3 - 28mm)



KA-7074

Tubing Cutter

ZINC BODY. NYLON KNOB
SK-2 CUTTING WHEEL
CAPACITY: 1/8" - 1 1/8"
(3 - 30mm)



KA-7075

Tubing Cutter

ZINC BODY. NYLON KNOB W/ T.P.R.
SK-2 CUTTING WHEEL
CAPACITY: 1/8" - 1 1/8"
(3 - 30mm)



KA-7076

Zip Action Tubing Cutter

ALUMINUM ALLOY DIE CASTING BODY
CAPACITY: 1/4" - 3"
(6 - 76mm)



KA-7077

Pipe Cutter

FOR IRON PIPE CUTTING
DUCTILE BODY
SK2 CUTTING WHEEL
CAPACITY: 1/8" - 2"
(3 - 50mm)



KA-7078

Zip Action Tubing Cutter

ALUMINUM BODY
ZINC KNOB
SUJ-2 CUTTING WHEEL WITH SPECIAL HEAT-TREATED
SPARE CUTTING WHEEL INCLUDED
CAPACITY: 1/4" - 2 1/2"
(6 - 38mm)



KA-7079

Zip Action Tubing Cutter

ALUMINUM ALLOY DIE CASTING BODY
SUJ-2 CUTTING WHEEL
RETRACTABLE DE-BURRING BLADE
CAPACITY: 1/8" - 1 1/4"
(4 - 32mm)



KA-7080

Zip Action Tubing Cutter

ALUMINUM BODY, ZINC KNOB
SPARE CUTTING WHEEL INCLUDED
SK2 CUTTING WHEEL
POLISHED ROLLER
CAPACITY: 1/4" - 1 1/4"
(6 - 32mm)



KA-7081

Pipe Cutter

ALUMINUM ALLOY DIE CASTING BODY
CAPACITY: 5/8" - 2 1/8"
(16 - 54mm)



KA-7082

Zip Action Tubing Cutter

ALUMINUM ALLOY DIE CASTING BODY
SUJ-2 CUTTING WHEEL
RETRACTABLE DE-BURRING BLADE
CAPACITY: 1/4" - 1 1/2"
(6 - 38mm)



KA-7083

Telescopic Tubing Cutter

ALUMINUM ALLOY DIE CASTING BODY
CAPACITY: 1/4" - 2"
(6 - 50mm)



KA-7084

Zip Action Tubing Cutter

ALUMINUM ALLOY DIE CASTING BODY
CAPACITY: 1/4" - 3"
(6 - 76mm)



KA-7085

Zip Action Tubing Cutter

ALUMINUM ALLOY DIE CASTING BODY
CAPACITY: 2" - 5 1/2"
(50 - 140mm)



KA-7086

Zip Action Tubing Cutter

ALUMINUM ALLOY DIE CASTING BODY
CAPACITY: 4" - 6 1/2"
(100 - 168mm)



**KA-7087K
Flaring Tool**

DUCTILE YOKE
9/16" SCREEN BAR
CAPACITY: 3/16", 1/4", 5/16",
3/8", 7/16", 1/2" &
5/8"



**KA-7088K
Flaring Tool**

DUCTILE YOKE
9/16" SCREEN BAR
CAPACITY: 3/16", 1/4", 5/16",
3/8", 7/16", 1/2" &
5/8"



**KA-7089K
Flaring Tool**

CARBON STEEL DROP FORGED
YOKE.
5/8" HEAT TREATED BAR.
CAPACITY: 3/16", 1/4", 5/16",
3/8", 7/16", 1/2" &
5/8"



**KA-7090K
Flaring Tool**

DUCTILE YOKE
9/16" SCREEN BAR BLACK
PAINTED.
CAPACITY: 3/16", 1/4", 5/16",
3/8", 7/16", 1/2" &
5/8"



**KA-7091K
Flaring Tool**

CARBON STEEL DROP FORGED
YOKE.
9/16" SCREEN BAR.
CAPACITY: 3/16", 1/4", 5/16",
3/8", 7/16", 1/2",
5/8" & 3/4"



**KA-7092K
Flaring Tool**

DUCTILE YOKE
9/16" SCREEN BAR
CAPACITY: 3/16", 1/4", 5/16",
3/8", 7/16", 1/2" &
5/8"



**KA-7093K
Double Flaring Tool**

KA-7088K PLUS 7PCS ADAPTERS.
FOR 3/16", 1/4", 5/16", 3/8",
7/16", 1/2" & 5/8"



**KA-7094K
Double Flaring Tool,
Tubing Cutter &
Deburring Tool Kit**

TUBING CUTTER & DEBURRING
TOOL KIT.



**KA-7095K
Double Flaring Tool Kit**

1 SET FLARING TOOL.
1 PC DEBURRING TOOL.
1 PC MINI TUBING CUTTER 1/8" -
5/8"
7 PCS ADAPTERS: 3/16", 1/4",
5/16", 3/8", 1/2", 7/16", 5/8"



**KA-7096K
Flaring Tool**

KA-7088K PLUS 7 PCS
ADAPTERS.
FOR 3/16", 1/4", 5/16", 3/8",
7/16", 1/2" & 5/8"



**KA-7097K
Flaring Tool Kit**

DROP FORGED YOKE, 5/8"
SCREEN BAR.
5 PCS ADAPTERS
CAPACITY: 3/16", 1/4", 5/16",
3/8", 1/2"



**KA-7098K
Tubing Cutter And Double
Flaring Tool Kit**

Flaring Tool : 3/16", 1/4", 5/16",
3/8", 7/16", 1/2", 5/8"
7pcs Adapters : 3/16", 1/4",
5/16", 3/8", 7/16", 1/2", 5/8"
Tube Cutter : 1/8"~1-1/8"(3~30
mm)



**KA-7099K
Tubing Cutter And Flaring
Tool Kit**

DUCTILE IRON YOKE
9/16" SCREEN BAR & KA-7057
TUBING CUTTER.



**KA-7100K
Tubing Cutter And Flaring
Tool Kit**

DROP FORGED YOKE, 5/8"
SCREEN BAR.
5 PCS ADAPTERS AND TUBING
CUTTER.
CAPACITY: 3/16", 1/4", 5/16",
3/8", 1/2"



**KA-7101K
Tubing Cutter And Flaring
Tool Kit**

KA-6840 TUBE CUTTER & 4 PCS
SPRING TUBE. (METRIC OR INCH
SIZE)
METRIC SIZE: 10, 12, 14, 16mm
INCH SIZE: 3/8", 7/16", 1/2",
5/8"



**KA-7102K
Flaring & Swaging Kit**

CARBON STEEL DROP FORGED
YOKE. 5/8" SCREEN BAR x 2
WITH 6 PCS SWAGING DIES.
FOR 1/8", 3/16", 1/4", 5/16",
3/8", 7/16", 1/2", 5/8" & 3/4"



**KA-7103K
Tubing Cutter And Flaring
Tool Kit**

FLARES FOR 3/16", 1/4", 5/16",
3/8", 7/16", 1/2", 5/8"
CUTTING FOR 1/8" - 1 1/4" (3 -
32mm)



**KA-7104K
Tubing Cutter And Flaring
And Swaging Tool Kit**

FLARES FOR 1/8", 3/16", 1/4",
5/16", 3/8", 7/16", 1/2", 5/8",
3/4"
CUTTING FOR 1/4" - 1 1/2"
(6-38mm)
6PC SWAGING DIES



**KA-7105K
Tubing Cutter And Flaring
And Swaging Tool Kit**

FLARES FOR 1/8", 3/16", 1/4",
5/16", 3/8", 7/16", 1/2", 5/8",
3/4"
CUTTING FOR 1/8" - 1 1/4"(3 -
32mm)
6PC SWAGING DIES



**KA-6371K
Tubing Cutter & Flaring
Tool Kit**

INCH & MILLIMETER SIZE: 4.75,
5, 6, 8, 10mm, 1/4", 1/2"
INCH SIZE: 3/16", 5/8", 1/2",
7/16", 3/8", 1/4", 5/16"
MILLIMETER SIZE: 4, 6, 8, 10, 12,
14, 16mm



**KA-7106K
Tubing Cutter & Flaring &
Swaging Tool Kit**

FLARES 1/8", 3/16", 1/4", 5/16",
3/8", 7/16", 1/2", 5/8" AND 3/4"
O.D. (1/8", 1/4", 3/8", 1/2", 5/8"
NOM.)
INCLUDES 5 SWAGE ADAPTERS
WHICH COVER 3/16", 1/4", 5/16",
3/8", 1/2", 5/8", 3/4", O.D.(1/8",
1/4", 3/8", 1/2", 5/8" NOM.)
CUTTER CAPACITY: 1/8" ~ 1 1/8"
O.D. TUBING ALUMINUM ALLOY
BODY, CHROME PLATED FINISH
WITH A SPARE CUTTING BLADE.



**KA-7107K
Tubing Cutter & Flaring
Tool Kit**

DUCTILE YOKE.
9/16" SCREEN BAR BLACK
PAINTED.
CAPACITY: 3/16", 1/4", 5/16",
3/8", 7/16", 1/2" & 5/8"
CUTTER: 1/8" ~ 1 1/8"



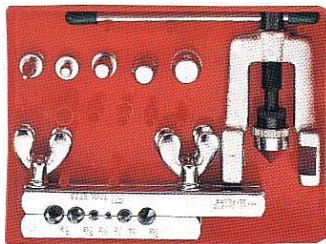

KA-7108K Flaring Tool Kit

Flares 1/8", 3/16", 1/4", 5/16", 3/8", 7/16", 1/2", 5/8" AND 3/4" O.D. (1/8", 1/4", 3/8", 1/2", 5/8" nom.)
 Includes 5 swage adapters which cover 3/16", 1/4", 5/16", 3/8", 1/2", 5/8", 3/4", O.D. (1/8", 1/4", 3/8", 1/2", 5/8" nom.)

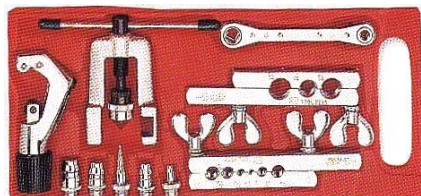

KA-7109K Flaring Tool Kit

Contains of kit: Flaring & swaging tool tube cutter, ratchet wrench



KA-7110K Flaring & Burnishing Tool

For 3/16", 1/4", 5/16", 3/8", 7/16", 1/2", 5/8" O.D. tubing



KA-7111K Flaring & Burnishing Tool

For 3/16" ~ 5/8" O.D. tubing. One opening holds all sizes



TUBING TOOL KITS

- KA-7125** Kit include 45° Eccentric Cone Type flaring tool, tube cutter, reamer.
- KA-7126** Kit include 45° Eccentric Cone Type flaring tool, tube cutter, reamer.
- KA-7127** Kit include 45° Eccentric Cone Type flaring tool, tube cutter, reamer.
- KA-7128** Kit include 45° Eccentric Cone Type flaring tool, tube cutter, reamer.



FLARING TOOLS

- KA-7129** Eccentric Cone Type flaring tool for 1/4", 5/16", 3/8", 1/2", 5/8", & 3/4" O.D. tubing.
- KA-7130** Eccentric Cone Type flaring tool for 6, 8, 10, 12, 16 & 19mm O.D. tubing.
- KA-7131** Eccentric Cone Type flaring tool for 1/8", 3/16", 1/4", 5/16", 3/8", 1/2", 5/8" & 3/4" O.D. tubing
- KA-7132** Eccentric Cone Type flaring tool for 4, 6, 8, 10, 12, 14, 16 & 19mm O.D. tubing



Brake Pipe Flaring Tool Kit

- Apply to high precision metal and stainless tube flaring.
- Accurate, Quick and Strength-saving
- Steel forged yoke
- For copper, steel , stainless pipe

KA-7728

Double flaring tool for sizes: 3/16", 1/4", 5/16", 3/8"
Die block: 3/16", 1/4", 5/16", 3/8"

KA-7728M

Double flaring tool for sizes: 4.75mm, 5mm, 6mm
Die block: 4.75mm, 5mm, 6mm

Tube Expander Kit

Kit include Handle, Plastic reamer 3/16" ~ 1-1/2"(3mm ~ 38mm) and Expand heads 6 sizes: 3/8", 1/2", 5/8", 3/4", 7/8" & 1" (10mm, 12mm, 15mm, 16mm, 18mm & 22mm) complete kit in a steel hand carrying case.



KA-7133K INCH SIZE

KA-7134K MM SIZE



KA-7133-HANDLE



KA-7133-HEAD Expand Heads

mm size , inch size could choice

- Expand Heads 1-1/8", 1-3/8", 1-5/8", optional
- Expand Heads 28mm, 35mm, 42mm, optional

KA-7135K Multi Sizes Tube Bender

For bending 8, 10, 12, 14, 16, 18, 22mm soft tubings. Bending worked by ratchet which can save power and do more efficiency bending. Complete set in a hand carrying case.

***** Soft tubing ratchet 15mm, 20mm, optional*****



ASSEMBLE



KA-7136K Multi Sizes Tube Bender

For bending 3/8", 1/2", 5/8", 3/4" and 7/8" soft tubing. Bending worked by ratchet which can save power and do more efficiency bending. Complete set includes 5 bending form wheels, tube cutter and reamer in a hand carrying case.

Fit for over 0.8mm copper tube.



Tube Bender

KA-7137 1/4" **KA-7138** 6mm
For 1/4" / 6mm O.D. tubing 180° degree bent.

KA-7139 5/16" **KA-7140** 8mm
For 5/16" / 8mm O.D. tubing 180° degree bent.



Tube Bender

KA-7141 3/8" **KA-7142** 10mm
For 3/8" / 10mm O.D. tubing 180° degree bent.

KA-7143 1/2" **KA-7144** 12mm
For 1/2" / 12mm O.D. tubing 180° degree bent.



KA-7145 4-IN-1 Bender

For 3/16", 1/4", 5/16", 3/8" O.D. tubing with fixed hook, bends up to 180°



4-IN-1 Bender

KA-7146 5/8" **KA-7147** 16mm
For 5/8" / 16mm O.D. tubing 180° degree bent.

KA-7148 3/4" **KA-7149** 19mm
For 3/4" / 19mm O.D. tubing 180° degree bent.

KA-7150 7/8" **KA-7151** 22mm
For 7/8" / 22mm O.D. tubing 180° degree bent.



KA-6367 3-IN-1 Tube Bender

For 1/4", 5/16", 3/8" O.D. tubing 90° degree bent.

KA-6367M 3-IN-1 Tube Bender

For 6mm, 8mm, 10mm O.D. tubing 90° degree bent



KA-6366 3-IN-1 Bender

For 1/4", 5/16", 3/8" O.D. tubing with fixed hook, bends up to 180

KA-6366M 3-IN-1 Bender

For 6mm, 8mm, 10mm O.D. tubing with fixed hook, bends up to 180

KA-6365 4-IN-1 Bender

For 3/16", 1/4", 5/16", 3/8" O.D. tubing with fixed hook, bends up to 180

KA-6365M 4-IN-1 Bender

For 5mm, 6mm, 8mm, 10mm O.D. tubing with fixed hook, bends up to 180

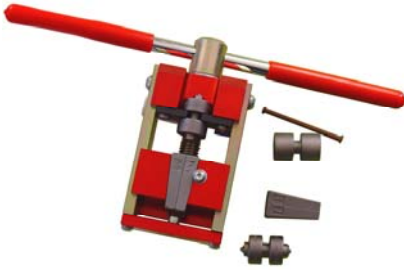

KA-6502 Automatic Universal Flaring Tool

Tool works in two steps for thin walled steel, aluminum or copper pipes. For dimensions of 3/16" (4.75mm) and 1/4" (6mm).
Fast manual flaring tool with minimal material wastage.



KA-7154 Flaring Tool

Carbon steel punch head w/heat treated 3/4" screen bar black oxide
Capacity: 10, 12, 14, 16, 18, 20, 22mm



KA-7153 Flaring Tool

Carbon steel punch head w/heat treated 9/16" screen bar black oxide
Capacity: 10, 12, 14, 16mm



KA-7152 Deluxe Flaring Tool

6 in 1 Flaring Tool
Capacity: 3/16", 1/4", 5/16", 3/8", 1/2", & 5/8"

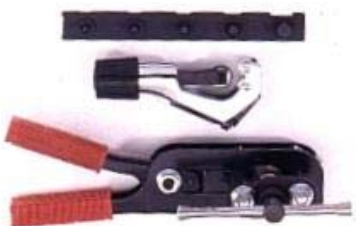

KA-6837 Flaring Tool Kit



KA-7157 5 IN 1 Adaptor For Double Flaring

Medium Carbon Steel.
Size: 3/16", 1/4", 5/16", 3/8", 1/2"



KA-6368 Tube Bender
3/16", 1/4", 5/16", 3/8",
4mm, 6mm, 8mm, 10mm



KA-6369 360° Tube Bender
3/16", 1/4", 5/16", 3/8"
4mm, 6mm, 8mm, 10mm



KA-6370 Tube Bender
360°, 1/2"



KA-6374 Tubing Bender
1/4", 3/8" (steel)



KA-6375 Tubing Bender
1/4" (steel)



KA-6376 Tubing Bender
1/4" (zinc)

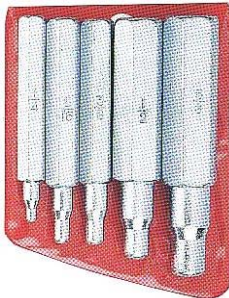

KA-7112K Swaging Punch

Swaging punch for 1/4", 5/16", 3/8", 1/2" & 5/8" O.D. tubing



Swaging Punches

KA-7115 for 1/4", 5/16", 3/8", 1/2", 5/8"
KA-7116 for 8, 10, 12, 14, 16mm



Spring Bender

KA-7117 size 1/4", length 10"
KA-7118 size 5/16", length 10"
KA-7119 size 3/8", length 10"
KA-7120 size 1/2", length 12"
KA-7121 size 5/8", length 14"
KA-7122 size 3/4", length 14"



1/2" Ratchet Wrench

KA-7123 4 size: 1/4", 3/16" square 9/16", 1/2" hex ratchet
KA-7124 4 size: 1/4", 3/8", 3/16", 5/16" square ratchet



KA-7158 Adapters For Double Flaring

Medium carbon steel

Sizes: 3/16", 1/4", 5/16", 3/8", 7/16", 1/2" & 5/8"



KA-7159 Cutting Wheels

Size: 3.0mm, 5.8mm, 6.3mm, 18.5mm



KA-7160 19mm Counter SINK



KA-6858 H/D Welding Crimping Tool



Breaking Bending

- Carbon steel drop forged body

KA-7155 for 3/16" O.D. tube

KA-7156 for 3/16", 1/4" O.D. tube



KA-1339 180° Brake Pipe Bender

- For 1/8"(3mm), 3/16"(4mm), 1/4"(6mm) copper
- Light tool and easy operation



KA-1339A Rolling-Cam Tubing

- Bender size: 3/16" & 1/4"
- Light tool and easy operation
- Suitable for any angle and restriction working place.

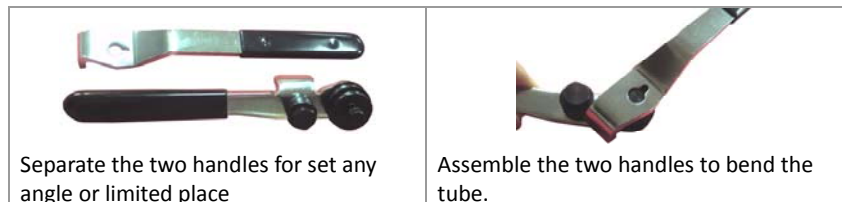

Separate the two handles for set any angle or limited place

Assemble the two handles to bend the tube.



KA-6979 Hydraulic Flaring Tool Kit

- This flaring kit includes various sizes of dies and adapters to work on flaring tube of GM fuel line, brake line, transmission line and A/C line.
- One 45 degree adapter is suitable for working a double flare.
- A big handle on the hydraulic pump helps save energy.
- The set is packed with a case for easier and safer storage for dies and adapters.



Specification:

	Metric bubble flare	Double flare	GM fuel line forming	Push-connect forming
A. Flaring dies	4mm(5/32"), 6mm, 8mm, 10mm	3/16", 1/4", 5/16", 3/8", 1/2"	5/16", 3/8"	1/4", 5/16", 3/8"
B. Flaring adaptors				
C. 45° flaring adapter				

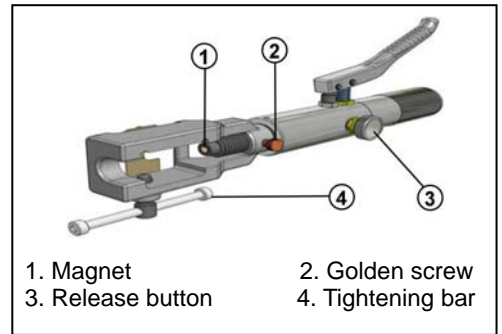

* Please note that an adapter and the dies can form a pair, and the pair shares the same size.

Instruction:

Step 1: Prepare a tube, the hydraulic pump and a correct sized flaring adapter and the dies.



Step 2: Put the tube between the flaring dies. The top of the tube should be even with the top of the dies.



Step 3: Put the dies and the tube into the seat and rotate the tightening bar to fix the dies firmly.

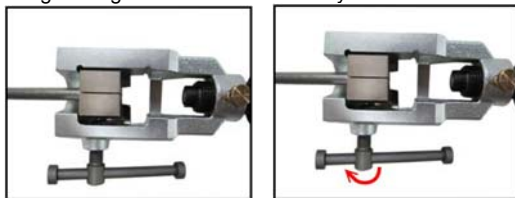

Step 4: Put the flaring adapter into the adapter seat. A magnet is attached to the seat to help fix the adapter securely.

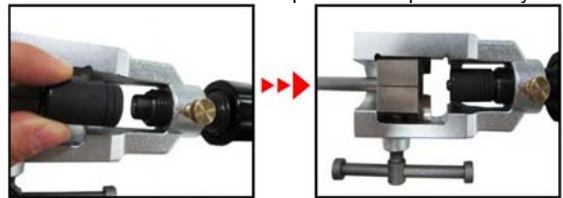

Step 5: Rotate the hydraulic cylinder until the adapter inserts into the tube. Turn the golden screw clockwise to the hydraulic cylinder spindle tightly.



Step 6: Turn the release button clockwise to lock it, and then push the handle on the hydraulic.

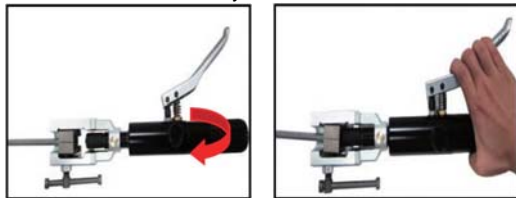

Step 7: To remove the flaring dies, turn the release button and the tightening bar anti-clockwise.

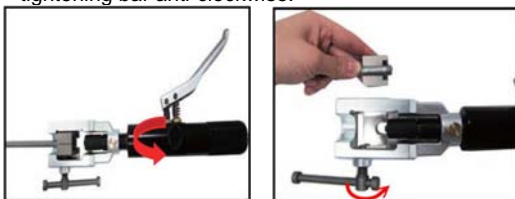

Step 8: Remove the flaring adapter and put them back into the storage case.



Completed metric bubble flare

KA-5271 Pipe Deburring Tool

- Internal/External
- An essential tool for ensuring brake pipes are deburred effectively.
- Internal / external deburring tool
- Size range: Internal 3-12mm
External 4-14mm
- Ideal for brake pads



KA-5347 Tube Straightener

- Capacity: 3/16" ~ 1/2" (4.75 ~ 15mm)
- Application: softy metal tube, copper, steel tube.
- Notice: No collision, No operate with high temperature.



Brake Flaring Tool Set

- The tool works on Cupro-Nickel and steel pipes as well as coated steel piping.
- Can be used in-situ.
- The set incorporates the tools to flare 4.75mm, 5mm and 6mm pipes by using the correctly sized die and punches.



KA-4512



KA-4512A

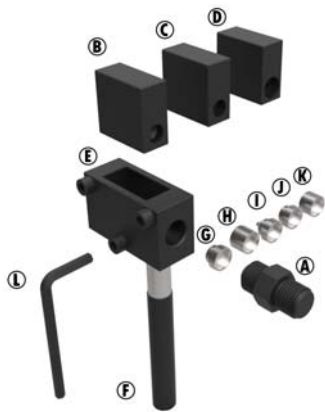

- A. 1 x force screw
- B. 1 x pair 4.75mm (3/16") dies
- C. 1 x pair 5mm dies
- D. 1 x pair 6mm dies
- E. 1 x main part
- F. 1 x handle
- G. 1 x SAE operation 1:4.75 (3/16") & 5mm punch
- H. 1 x SAE operation 1:6mm (1/4") punch
- I. 1 x SAE operation 2:4.75 (3/16") & 5mm & 6mm (1/4") punch
- J. 1 x DIN 4.75 (3/16") & 5mm punch
- K. 1 x DIN 6mm (1/4") punch
- L. 1 x Hex wrench 5mm



Operation:

<p>1.</p> <p>Identify and assembly the correct dies for the flare and pipe size required and tighten the forcing screw. Note: the 3 screw just mount them in position temporarily</p>	<p>2.</p> <p>Assemble the dies and pipe as shown with the pipe end flush with top of the screw and put in the pipe</p>
<p>3.</p> <p>Locking the screw by Allen wrench</p>	<p>4.</p> <p>Select the required punch and fit into screw, and insert the punch/screw combination into forcing screw. Tighten the forcing screw and aligns with the end of the pipe.</p>
<p>5.</p> <p>Unscrew the screw by Allen wrench</p>	<p>6.</p> <p>Unscrew the forcing screw and take out the pipe.</p>

KA-7129A
Ratchet & Drill Powered
Flaring Tool Kit

Flaring Tool Kit Traditional Type
 Size: 6.8.10.12.14.16.19 Mm +
 1/4".5/16".3/8".1/2".5/8".3/4"
 With Cutter & Reamer
 With Carrying Case



KA-7129B Flaring Tool
 Kit with 1/2" * 6mm Hex
 Wrench Bit

Aluminum Flaring Body And Bar
 Size: 6.8.10.12.14.16.19mm +
 1/4".5/16".3/8".1/2".5/8".3/4"
 With Cutter & Reamer
 With Carrying Case



KA-7129C
Flaring Tool Kit With Air
Wrench Bit

Steel Flaring Body And Bar
 6 Size
 1/4".5/16".3/8".1/2".5/8".3/4"
 O.D. Tubing
 With Cutter & Reamer
 With Carrying Case



KA-7129D
Flaring Tool Kit 45°
Eccentric Cone Type

Steel Flaring Body And Bar
 6 Size
 1/4".5/16".3/8".1/2".5/8".3/4"
 O.D. Tubing
 With Cutter & Reamer
 With Carrying Case



KA-7129E
Ratchet Type Flaring Tool
Kit

Steel Flaring Body And Bar
 Size: 6.8.10.12.14.16.19 Mm +
 1/4".5/16".3/8".1/2".5/8".3/4"
 With Cutter & Deburring Tool
 With Carrying Case



KA-7129F
Flaring Tool Kit
Traditional Type

Flaring Tool Kit Traditional Type
 Size: 6.8.10.12.14.16.19 Mm +
 1/4".5/16".3/8".1/2".5/8".3/4"
 With Cutter & Reamer
 With Carrying Case



KA-7135KN Multi-Function Tube Bender Set

- Multi-Function Tube Bender Set
- Tube Bender + Reverse Direction Bending + Aluminum Forms
- Aluminum Forms 1/4.5/16.3/8.1/2.5/8.3/4.7/8"
- Aluminum Reverse Direction Bending
- With Cutter And Reamer
- With Carrying Case



KA-7111KN Sliding Die-Block 45° Flaring Tool

Flaring tool kit - 45° Single lap
 Size: 3/16", 1/4", 5/16", 3/8", 1/2", 5/8" O.D. Tubing

KA-7111KM SLIDING DIE-BLOCK 45° FLARING TOOL

Flaring tool kit - 45° Single lap
 Size: 6, 8, 10, 12, 16mm O.D. Tubing