



KA-3353



KA-3354



**Motorcycle Working Stand**

Item No.	KA-3353	KA-3354
Length	770mm	700mm
Width	400mm	310mm
Height	390mm	310mm
Support Rack type	 Parts No.KA-3353P	 Parts No.KA-3354P



**KA-3355 Wheel Balance Stand**

- Height: 380mm
- Width: 330mm



**KA-3356 H/D Wheel Balance Stand**

- Height: 450mm
- Width: 310mm



**KA-3357 Wheel Spin**

No more need to your bike back and forth to lube the chain or clean the wheels, Wheel-Spin is the perfect solution to this problem. This kit enables the user to freely rotate either wheel whilst the bike is parked on its side stand. Place it on the floor in front of your wheel, push the wheel on top of Wheel-Spin rest the bike on its side stand and you can turn your wheel. Adjusts to suit all sizes, folds for carrying.

Size: 135~170mm with 4pcs 1" Ball (360° swivel)





**Spoke Wrench Set**  
 ■ Used for adjuster wheel balance

**KA-3356K**  
 9pcs: 5.2, 5.4, 5.6, 5.8, 6.0, 6.2, 6.4, 6.6, 6.8

**KA-3356K-A**  
 10pcs: 5.2, 5.4, 5.6, 5.8, 6.0, 6.2, 6.4, 6.6, 6.8, 7.0

**KA-3356K**

**KA-3356K-A**



**KA-5073 Chain Spindle Extractor Install Tool**

- Heavy Duty (3m/m~5m/m)
- For chain: 428, 430, 520, 525, 530

**Roller Chain Detacher**



**KA-3366**  
 25-60mm

**KA-3367**  
 60-100mm



**KA-3449 Chain Tool**  
 3mm, 4mm, 5mm



**KA-3363 Chain Holder**  
 For chain size: 428, 520, 525, 528, 530



**KA-2996 H/D Chain Breaker**  
 For chain: 420, 428, 520, 525, 530, 532



**KA-2955 Chain Breaker Tool**  
 For chain: 420, 428, 430, 520, 530



**KA-2816 Chain Breaker Tool**  
 For 415, 420, 428, 520, 525, 530



**KA-2840 Chain Breaker & Riveting Tool Set**  
 For chain: 428, 430, 520, 525, 530



**KA-2995 Chain Cleaning Kit**

- Longer service life
- More power
- Simple - Fast - Easy
- Increased safety
- 6pcs Brush

**Operation:**

**Putting into place**



**Handing in**



**Cleaning**



**Accessory**



**KA-2995P Changeable Brush Set**

(6 pc/set)

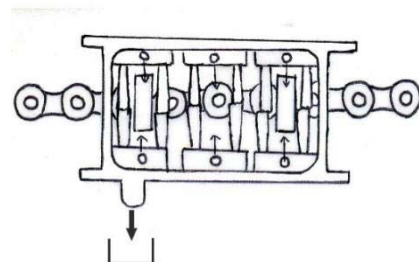

**KA-2824 Chain Brush**

- with adjustable brushes

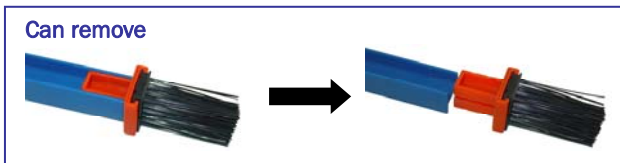

**KA-3450 Engine Inside Chain Tool**

**Front Fork Oil Seal Pusher**



**KA-6620**  
 ■ 35~45mm  
 ■ White box



**KA-6620S**  
 ■ 30~45mm  
 ■ Metal Box



**KA-6620M**  
 ■ 35~47mm



**KA-6620N**  
 ■ 42~54mm



- A Fork Oil Seal Pusher that can be used in Normal Position or even Upside Down!
- Trisect attachments.
- Bisect hammer.
- Inner Tube installs the Front Fork Oil Seal with outer diameter Ø 35- Ø 45mm easily and accurately.

Adjust the positions of trisect attachment accurately and then hammer in the oil seal with the slide hammer.

Material:  
 Attachment: Nylon  
 Hammer: Inner side is pasted with Vinyl Chloride.  
 Above material causes NO damages to the Inner Tubes.



**Inner Tube**  
**Slide Hammer**  
 ■ 01A Hammer A(Pin Side)  
 ■ 02A Hammer B(Hole Side)  
 ■ 02 Hammer Collar (Vinyl Chloride)  
**Attachment**  
 ■ 03 Fixation Cap  
 ■ 04 Collar (3pcs/set)  
 ■ 06 Small Round Screw M4 x 8  
**Oil Seal**  
**Outer Tube**  
 (Bottom Case)

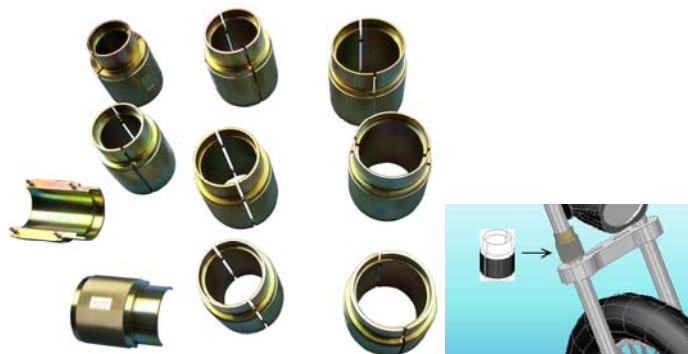

**KA-6620K 9pcs Seal Driver Kit**

- Split design and CAD-II plated carbon steel
- Contents:  
**KA-6620B** 49/50mm combo, fork seal drivers  
**KA-6620C** 45mm fork seal drivers  
**KA-6620D** 43 mm fork seal drivers  
**KA-6620E** 41 mm fork seal drivers  
**KA-6620F** 39 mm fork seal drivers  
**KA-6620G** 35/36 mm combo, fork seal drivers  
**KA-6620H** 48 mm fork seal drivers



46~54mm

30~45mm

**KA-6620SL Master Fork Seal Drivers**  
 Range: 30~54mm



**KA-9004**  
**T-Handle Disc Losed Tire Repair Tool Kit**



**KA-9004-5**  
**2pc T-Handle Radial Tire Repair Kit**



**KA-9004-8** 2pc Handle Radial Tire Repair Kit



**KA-9004-30** Tire Seal Refill 30pc/Box



**KA-7023 Rim Protector**  
Convenient tool while changing the tire with the weight



**KA-6889** Tire Crush Tool



**Tire Lever**  
**KA-2416** 240mm (9.5")  
**KA-2417** 280mm (11")  
**KA-2418** 380mm (15")  
**KA-2419** 530mm (21")

**KA-7022** Tire Lever  
Suitable for passenger cars, motorcycle and industrial tyres. Made with high quality drop forged and tempered alloy steel.  
Length: 11"(280mm)  
Width:1"(25mm)



**KA-4185**



**KA-4185A**

**Off-Road Tire Tool**  
**KA-4185 KA-4185A**

- Good auxiliary tool for tire irons when replacing the tire of off-road and also a must for installing tubes. Provides an easy way to push the tire bead down into the drop center of the rim on off-road wheels while using tire irons to change tires. Slip the slot of the tool over the spoke and push bead down on opposite side of tire from tire irons.
- It will facilitate pulling the tire over the edge of the rim; allow the tire removal and installation easier and faster.
- No more fighting to keep bead down while installing off-road tires.
- Material: SUS 304

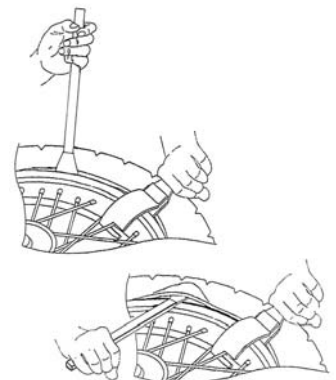



**KA-3463 1/4 T-Type shaft - 380L**



**KA-3464 1/4 T-Type shaft - 175L**



**KA-3465 1/4 T-Type shaft - 66L**



**KA-6885 Socket Type Tire Lever**  
 ■ H17m/m



**KA-6883 Socket Type Tire Lever**  
 ■ H15m/m



**PA-3627D 4 WAY TIRE VALVE REPAIR TOOL**



**KA-3382 Screw Bit Shaft**



**KA-3383 Screwdriver**  
 ■ 28m/m x 120mm



**KA-6887 Nipple Wrench**



**KA-6888 T-Type Ratchet - H14m/m**



**KA-3471 Suspension Hook Wrench Tool**  
 60mm x 65mm

**KA-2546 Hook Wrench**  
 30mm x 40mm



**Lock Nut Wrench**  
**KA-3372A** 35mm  
**KA-3372B** 36mm  
**KA-3372C** 39mm



**KA-2839 CARBURETOR'S GAUGE**  
 ■ 0~45mm L:102mm



**KA-2958K Universal Camshaft Pulley Holding**

Professional kit to lock the camshaft pulley  
 Small and compact, complete with  
 2 pin 5 x 8mm, 2 pin 6 x 10mm, 2 pin 7.5 x 18mm, 2 cam pin, 2 pin 3/8"



**KA-2841 Universal Holder**

- To hold flywheel & clutch pulleys
- With flat notches & opening from 70 to 125mm



**KA-3360 Universal Holder**

Stop the flywheel, clutch & Pulley from rotating while repairing job is done.  
 ■ With 5 & 9mm  
 ■ L: 320mm (12-1/2")

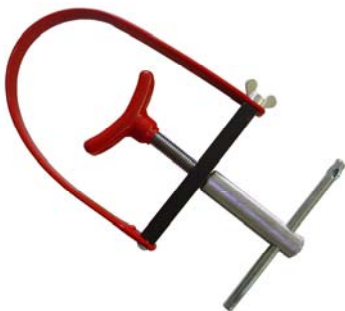
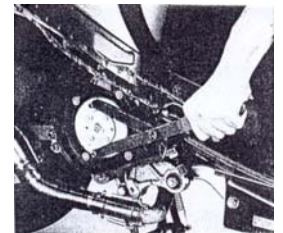
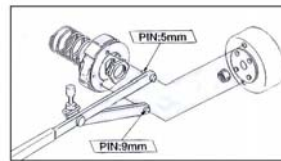

**KA-6882 Pulley Holder**

- Two adjusting holes for minimal adjustment.
- To extend the durability of the tools and securing the object in the minimum length of the belt, do not pull the belt violently.
- Capacity: from Ø 45 to 120 mm

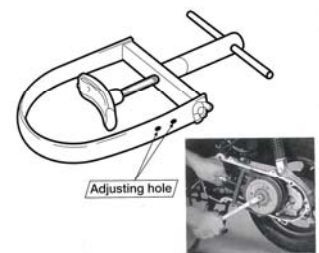

**KA-7020 Flywheel Puller**

The tool is specially designed for the standard AC Flywheel wheel ring. Suitable for all Tamper Lock type flywheel wheel rings (6 sizes).

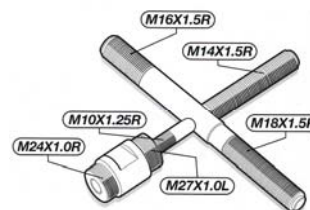



**KA-3461**  
Fly Wheel Puller Tool  
■ Diameter 100"



**KA-4186** Flywheel puller  
■ Puller kit designed to pull magneto flywheel or starter gear.  
■ Includes three 6 x 25mm and three 8 x 40mm bolts.  
■ Applications: Kawasaki Jet Ski 300/440/550, Yamada WR250F 01-02 and WR400F flywheel.

**Flywheel Puller Tool**



**KA-3408**  
■ 28M x P1.0(R)



**KA-3409**  
■ 27M x P1.0(L)



**KA-3410**  
■ 24M x P1.0(R)



**KA-3411**  
■ 16M x P1.5(R)



**KA-3412**  
■ 14M x P1.5 (R)



**KA-4074** Flywheel Puller  
For Bombardier/Cam-Am DS 650 00-07

- 38mm x 1.5 right hand internal thread.
- Lubricate all areas before use.

**KA-7669 10pc Flywheel Drive Puller Set**

- **Application:** YAMAHA, CAGIVA, MOTOPLATT, SUZUKI, SFERA, KAWASAKI, HONDA, KYMCO, PEUGEOT, BOSCH, MBK, KOKUSAN, DUCAN, PEUGEOT, MINARELLI, GLERA, KIMOO, DUCATI, SAM

■ **Contents / Size:**

KA-7669-1	M28 x P1.5
KM-7669-2	M27 x P1.25 M20 x P1.0
KS-7669-3	M26 x P1.5 M22 x P1.5
KA-7669-4	M28 x P1.0 M26 x P1.0
KA-7669-5	M25 x P1.5 M22 x P1.0
KA-7669-6	M27 x P1.0L M24 x P1.0
KA-7669-7	M19 x P1.0
KA-7669-8	M14 x P1.5
KA-7669-9	M16 x P1.5
KA-7669-10	M18 x P1.5

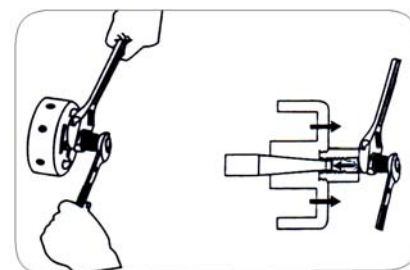

**Notice:** The plier connector should be fixed with the 19mm wrench. And take out the Flywheel after the plier rotary shaft is inserted into the plier connector.



**Flywheel Pilot Bearing Pullers**

Makes quick work of pulling stubborn and rusted bearings. The forcing screw expands the jaws inside the bearing, and at the same time, pushes against the crankshaft.

- KA-6681** For 1" I.D
- KA-6682** For 1-1/4" I.D





**KA-3466 Fly Wheel Puller Tool**  
 ■ 27M(L) x 24M(R)



**KA-3467 Fly Wheel Puller Tool**  
 28M(R)vespa



**KA-3451 Fly Wheel Puller Tool**  
 ■ 10-14-16-18mm



**KA-1261 27mm Motorcycle Flywheel / Mag Puller**



**KA-6885K 25pcs Motorcycle Repair Kit**



**KA-3459 Repair Tool Kit (32pcs)**



**KA-3873 90° Internal Snap Ring**

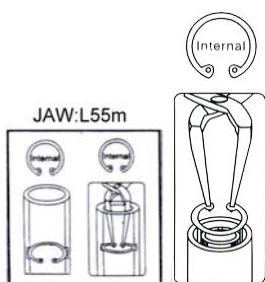

**KA-6318 3-IN-1 Snap Ring Plier (10~50mm)**



**KA-3376 Snap Ring Plier**



**KA-6316 Snap Ring Plier (10~50mm)**



**KA-3460 Piston Spindle Tool**

- 13, 15, 16, 19, 22mm



**KA-3452 Piston Spindle Tool**

- 13-15-16-19mm



**KA-5011 Piston Ring Installer**

- Save by reducing ring breakage.
- Tapered jaws to remove and install most passenger car and light truck rings from 3/64" TO 1/4" (1.2-6.3mm)



**KA-3870 Piston Detaching Tool**

- This tool is purpose designed to detach a piston from the disk brake base of a motor vehicle. The adjusting screw design, which is able to adjust the distance between two grasping portions and make the outer walls of the two holding blocks firmly press the inner wall of the piston allows the operator convenient to replace a piston or a washer with a new one.
- Capacity: 16.5 ~ 40mm



**KA-3870A Piston Detaching Tool**

- This tool is purpose designed to detach a piston from the disk brake base of a motor vehicle.
- Allows the operator convenient to replace a piston or a washer with a new one.
- Capacity: 16.5 ~ 40mm

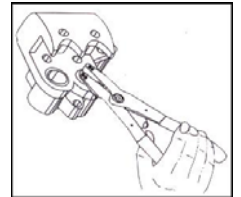

**KA-3870B Heavy Duty Piston Detaching Tool**

- Useful to disjoin the small piston from the disk
- Capacity 16.5 ~ 40mm



**KA-2953 Piston Locating Tool**

- M14 x P1.25
- For 2 stroke engines

**Piston Ring Compressor with Safety Valve**



	HIGH	CAPACITY
KA-2033	2" (50mm)	40~80mm
KA-2034	3" (75mm)	53~125mm
KA-2035	4" (100mm)	60~175mm
KA-2036	6" (150mm)	60~175mm
KA-6364A	3-1/4" (83mm)	57~127mm
KA-6364B	3-1/2" (88mm)	53~125mm
KA-6364C	3-1/4" (83mm)	88~178mm
KA-6364D	4" (100mm)	88~178mm
KA-6364E	6-1/2" (165mm)	90~175mm
KA-6364F	6" (150mm)	90~175mm

**KA-3134 Vice For Shock Absorber**

Useful to lock stems, tubes, pistons,...without any damage-to fix on wall or on worktable capacity from Ø 26 to Ø 72mm

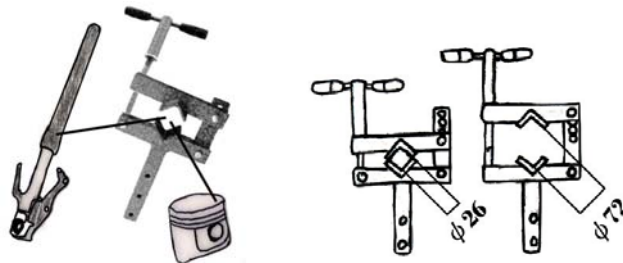

**Hook Spanner Wrench**

- KA-6853 3/4"~2"
- KA-6854 1-1/4"~3"
- KA-6855 2"~4-3/4"



**KA-7665 O-Ring Pick-Up Tool**

- L:95mm



**KA-7232K 11pcs Snap-Ring Plier Set (Internal & External)**



	TIP SIZE		TIP SIZE
5-1/2" BENT	0.38" (1.0mm)	8" STAIGHT	0.70" (1.8mm)
6" STAIGHT	0.38" (1.0mm)	8-1/2" BENT	0.90" (2.3mm)
5-1/2" BENT	0.47" (1.2mm)	9" STAIGHT	0.90" (2.3mm)
6" STAIGHT	0.47" (1.2mm)	2PC HOOK & PICK TOOL	
7-1/2" BENT	0.70" (1.8mm)		

**KA-6886K Bearing Puller Tool Kit (8~25mm)**

Contents:



<b>Frame</b>	Leg Range: 26-66m/m		
<b>Center Bolt</b>	8m/m(M) x 90m/m(L) P:1.25m/m		
<b>Center Nut</b>	8m/m(F) x 15m/m(L) x 14m/m(Hex) P:1.25m/m		
<b>Space Collar x 2pcs.</b>	22m/m(O.D.) x 8.2m/m(I.D.) x 20m/m(L)		
	22m/m(O.D.) x 8.2m/m(I.D.) x 8.6m/m(L)		
<b>Attachment</b>	8m/m - 11m/m	45m/m(L)	Hex: 14m/m
	10m/m - 13m/m	45m/m(L)	Hex: 17m/m
	12m/m - 15m/m	45m/m(L)	Hex: 17m/m
	15m/m - 17m/m	45m/m(L)	Hex: 17m/m
	17m/m - 20m/m	45m/m(L)	Hex: 19m/m
	20m/m - 24m/m	45m/m(L)	Hex: 26m/m
	25m/m - 29m/m	45m/m(L)	Hex: 26m/m
<b>Tapered Bolt x 2pcs</b>	8m/m(F) x 12m/m-P1.25(M) x 54m/m(L) Hex: 14m/m		
	8m/m(F) x 16m/m-P1.50(M) x 63m/m(L) Hex: 17m/m		
<b>Adapter x 2pcs</b>	1/2"-12T(F) x 8m/m-P1.25(M)		Hex: 21m/m
	5/8"-11T(F) x 8m/m-P1.25(M)		Hex: 21m/m

**KA-2124K Bearing Puller Tool**

(8m/m ~ 32m/m)

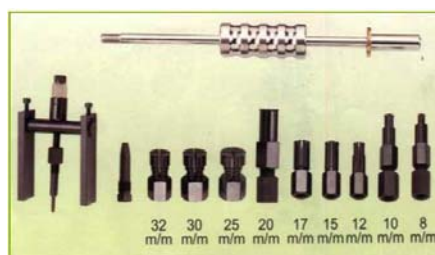

**KA-2432 Bearing Hole Puller Kit**



Part No.	Size	Description
2432-1	SHAFT	Slide Hammer Shaft 390MM/L
2432-2	HAMMER	Hammer Weight 100MM/L-2, 15lb(940g)
2432-3	8MM	5/16" to 13/32" (8-10MM)
2432-4	10MM	13/32" to 15/32" (10-12MM)
2432-5	12MM	15/32" to 9/16" (12-14MM)
2432-6	15MM	19/32" to 11/16" (15-17MM)
2432-7	17MM	11/16" to 25/32" (17-20MM)
2432-8	20MM	25/32" to 15/16" (20-24MM)
2432-9	25MM	1" to 1-1/8" (25-29MM)
2432-10	30MM	1-3/16" to 1-1/4" (30-32MM)

**Fixed Location:**



**KA-3348K 8pcs Bearing Remover Set**

■ Attachment size: 9.8, 11.8, 14.8, 16.8, 18.8, 19.8, 24.8, 29.8m/m



**KA-3456 Bearing Puller Tool**

■ 8, 10, 12, 15, 17, 20, 22, 25, 30, 32, 35, 40, 45mm



**KA-3457 Bearing Puller Tool**

■ 8, 10, 12, 15, 17, 20, 25, 30, 32, 35mm

**Bearing Attachment Tool**



KA-3413 (30m/m)



KA-3414 (25m/m)



KA-3415 (20m/m)



KA-3416 (17m/m)



KA-3417 (15m/m)



KA-3418 (12m/m)



KA-3419 (10m/m)



KA-3420 (8m/m)



**KA-1404 Pilot Bearing Puller (3 Jaw)**

Used for removing flywheel pilot bearings on cars, trucks, and tractors where working space is limited. Also very useful impaling bearings, and bushings on motors, generators, starters and magnetos. Steady pull with the screw type puller allows removal without shock to the bearing or housing, thus reducing the possibility of damage.  
Capacity: 1/2" - 2" (125 ~ 50mm)



**KA-3458 Bearing Oil Seal Install Tool**

8mm x 12mm	15mm	19.8mm x 30mm
10mm x 15mm	17mm	17mm x 30mm
17mm x 22mm	20mm	17mm x 28mm
20mm x 25mm	22mm	22mm x 32mm
30mm x 35mm	25mm	25mm x 37mm
	30mm	24mm x 43mm



**KA-3454 Bearing Install Tool**

8mm x 12mm	15mm
10mm x 15mm	17mm
17mm x 22mm	20mm
20mm x 25mm	22mm
30mm x 35mm	25mm
	30mm



**KA-3455 Oil Seal Install Tool**

19.8mm x 30mm
17mm x 30mm
17mm x 28mm
22mm x 32mm
25mm x 37mm
24mm x 43mm



**KA-5129 Metric Bushing Driver Set**

- Adaptors Held on drivers with knurled nut.
- Fit all remaining bushing.
- Size: 10 ~ 42mm





**KA-1311-3 2pc Bearing & Puller Separator Kit**

- Bearing separator 30~50mm



**KA-1311-1 2pc Bearing & Puller Separator Kit**

KA-1001 Bearing separator 1 1/4" - 2" (30-50mm)

KA-1002 Bearing separator 2" - 3" (50-75mm)

1. This combination set includes our two most popular bearing "splitters" (2" and 3"), four sets of hex push-puller legs and a bar type puller head with a 9/16" forcing screw. Separator tools are used with bar puller and legs for a wide variety of pulling jobs.
2. The 5" puller cross-bar with a 6-1/4" forcing screw or each of the bearing separators may also be used separately or in combination with other pullers or tools.



**KA-3298K Mini Bearing Separator Kit**

- Forcing screw 1/4" - 20T x L102mm
- Beam
- Main Rod 2pcs (Hex bar 8mm x L85mm x 1/4" - 20T)
- Extension Rod 2pcs (Hex bar 8mm x L40mm x 1/4" x 20T)
- Bearing separator Spread range: 10mm-30mm (SCM415 drop forged)
- Jaw 2pcs (L82mm)



**KA-2944 Bearing Remover/Installer Tool**

- 10-12-15-17-19-20-25mm



**KA-1020 10 Ton Multi Purpose Hyd. Gear Puller Kit**

- |                                  |      |
|----------------------------------|------|
| Contents: 1020-1 10 Ton hyd ram  | 1pc  |
| 1020-2 Combination cross head    | 1pc  |
| 1020-3 Combination leg           | 3pcs |
| 1020-4 Steel plate               | 6pcs |
| 1020-5 Extension rod 1" x 1-1/4" | 1pc  |
| 1020-6 Extension rod 1" x 2"     | 1pc  |
| 1020-7 Screw nut & washer        | 6pcs |



**KA-6553 Fast Fit Micro Puller**

- For rapid removal of small bearings
- Capacity: 1 ton
- Spread: 19~45mm (3/4" to 1-3/4")
- Reach: 73mm (2-7/8")



**KA-1262 Belt Tension Gauge**

This tool adjusts belt tension on most motorcycles equipped with a secondary drive belt. This tool provides a simple way to confirm the belt for proper tension.



**KA-1263 Tappet Adjusting Tool Set**

- Material: SC-M440
- Content three wrenches (8, 9 & 10mm) and three adjuster (screw type and 3 & 4mm square-type).
- Interchange adjusters and wrenches give nine different combinations.
- Applications:
  - HONDA: All ATC's and motorcycles with 4 cycle engines and screw type adjuster.
  - YAMAHA: SR 185/250, XT/TT250, XS400, ST185
  - SUZUKI: All 4 cycle ATV's and motorcycles with screw type adjusters.
- Any tappet adjuster with 8, 9 or 10mm adjusting nut and 3 or 4mm square or slotted adjuster.



**KA-1264 Motorcycle Turn Handle Bearing Extractor**

This high-quality tool is designed for shop or home mechanic. Made from alloy steel. The most convenient way for removing bearing. We could have got it done quicker. Optional removers are available for use on most models.

**KA-4273**

**Universal Bearing Puller Ring for Motorcycle Steering Head Bearings**

Very often, steering head bearings are replaced by workshop specialists. This is usually not what a motorcycle owner can do on its own.

Since the replacement can only be executed in the TÜV-certified workshops which are inspected regularly by officials.

The replacements for the steering head or crown are very expensive, complicated, and required enormous time and many tools such as angle grinders, welding torches, hammers and chisels. This is not economical for any conventional workshops.

- This tool set is designed to save time and money.
- Can repair and replace the head steering with simple this set of tool.
- Can be used to repair on 98% of models.

Content:

1. Puller for Inner Bearing Ring
2. Two keys: 35-40mm & 40-46mm
3. Packed in Blow Molded Case.





**KA-2125K Crank Pulley Puller**  
With accessories

**KA-3371 Crankcase Separator**

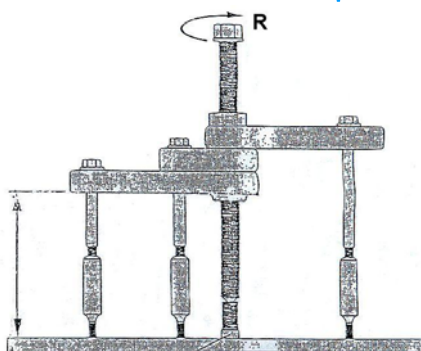

**KA-2921A Crankcase Separator**

Capacity: 22~120mm (DROP FORGED STEEL)

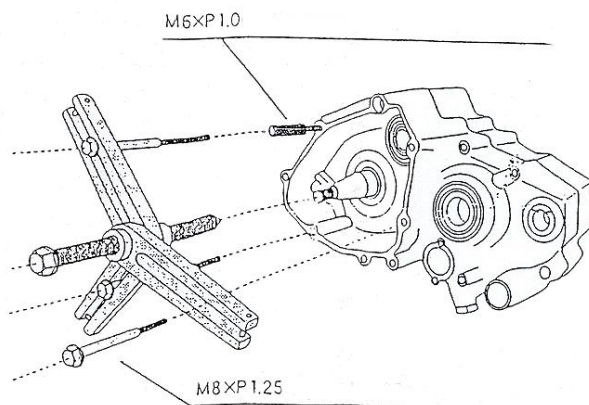
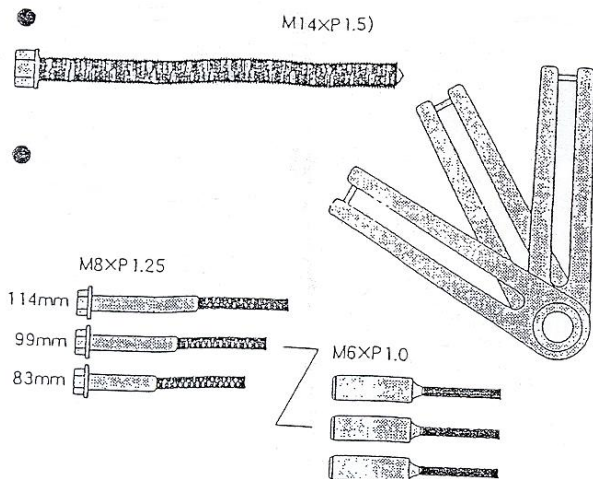
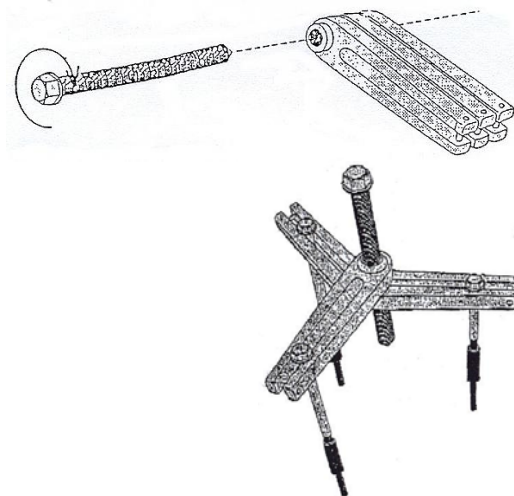





**KA-3349K Crank Pulley Puller (Heavy Duty)**



**KA-5031 Pulley Puller (Heavy Duty)**



**KA-3472 Steering. Attachment, tool**



**KA-3473 Oil funnel**



**KA-2957 Steering Wheel Puller**



**KA-3394 Steering Nut Tool**



**KA-3396 Start Wheel Puller**  
 ■ 24M x P1.0



**KA-3397 Start Wheel Nut Tool**  
 ■ H32m/m x 120 L



**KA-3398 Steering Nut**



**KA-3399 Steering Nut**



**KA-3393 Engine Start Gear Tool**



**KA-3402 Gear Nut Tool**



**KA-3395 Engine Start Gear Tool**



**KA-1260 20mm Gear Wrench**

- 72T
- L: 150MM



**KA-3406 Crank Install Tool**



**KA-3403 Tappet Adjust Tool**



**KA-3400 Engine Center Washer Tool**

- 20m/m x 17m/m



**KA-3401 Engine Center Washer Tool**

- 30m/m x 28 m/m



**KA-7039 90° Angle Driver Bit Set**



**KA-5548K 3pc Scraper Knife**



**KA-2838 Spark Plug Bolt Wrench**  
21 x 17mm & 32 x 27mm



**Turn Socket**  
**KA-3446** 10m/m  
**KA-3447** 12m/m



**Four Way Box Wrench**  
**KA-2948** 32~39mm  
**KA-2949** 34~41mm



**Fork Cap Wrench**  
For removing the fork caps on late-model RMs & CRs  
Can be used for removal of a compression stack on late-model RMs  
**KA-2950** 46~50mm  
**KA-2951** 49~50mm



**KA-2834 12 Point Pulley Lock Wrench**



**KA-2833 6 Point Pulley Lock Wrench**



**KA-2836 Head Set Wrench**  
■ L:230mm  
■ For tightening the steering nut



**KA-2837 Lock Rokee Washer Wrench**  
■ L:240mm



**KA-2832 Pulley "T" Lock Wrench**  
■ 14~17mm  
■ L:140mm



**KA-2843 Rotor Puller**



**KA-3469**  
Clutch Nut Tool  
Ø 17



**KA-3404**  
Clutch Nut Tool  
Ø 20



**KA-3405**  
Clutch Nut Tool  
Ø 24



**KA-3468**  
Clutch Nut Tool  
23mm x 20mm



**KA-3470**  
Clutch Nut Tool  
vespa



**KA-3387** Clutch Socket Tool  
■ 39m/m



**KA-3388** Clutch Socket Tool  
■ 41m/m



**KA-3389** Clutch Socket Tool  
■ 46m/m

**Clutch Nut Wrench**

- 2 cones
- L: 280mm



**KA-2825** 34mm

**KA-2826** 39mm

**KA-2827** 41mm

**KA-2828** 39mm & 46mm  
PIAGGIO-GILERA-TYPHOON  
STORM-NRG-STALKER  
RUNNER E MOTOR  
PURE-JET

**KA-2842** 46 x 72mm  
HONDA SCOOTER 125/150 4t  
KYMCO SCOOTER 125/150 4t



**KA-2829 Clutch Tool**

- 3 cones
  - 46mm
  - L: 300mm
- YAMAHA-MBK 50 2t  
MALAGUTI 50 2t  
KYMCO 50 2t  
PEUGEOT 50 2t  
SUZUKI 50 2t



**KA-2830 Clutch Outer Holder**

- L:315mm
- YAMAHA-MBK 50 2t  
MALAGUTI 50 2t  
KYMCO 50 2t  
PEUGEOT 50 2t  
SUZUKI 50 2t



**KA-2831 Clutch Outer Holder**

- L:280mm
- PIAGGIO-GILERA  
SFERA-ZIP-QUARTZ  
3 PIOLI/IVOTS/PINS



**KA-2906 Fan Clutch Holding Tool**

- New holder tool for removal and installation of Ford 6.0L PowerStroke Diesel engines from 2003 to present.
- Designed for Fan Clutch removal on 2003 and above Ford 6.0L Powerstroke engines.
- Unique fan clutch wrench grips and securely holds the pulley housing.
- Fan clutch holding tool loosens and removes oval or round hole clutch nut.



**KA-2945 Clutch Spring Check-Tool**

- For 125-250cc Engines with Ø 130-155mm pulley.



**KA-2946 Clutch Spring Check Tool**

- For 50-250cc engines with Ø 125-155mm pulley



**KA-2947 Clutch Spring Check-Tool**

- For 500cc engines with Ø 125mm max pulley



**KA-4187 Clutch Hub And Alternator Puller**

(for motorcycle)

Ideal tools to remove the indicated clutch plates.

Applications reference:

1. 45CC clutch
2. Big twin clutch-3, 5 and 10 finger
3. Big twin alternator cover
4. Big twin motor sprocket
5. Sportster transmission sprocket
6. Sportster clutch early and late



**KA-4184 Honda Oil Filter and Clutch Hub Spanner**

Designed for oil filter and clutch hub on many Honda models.

(single-cylinder and twin-cylinder machines)

- 3/8" driver and 24mm inside diameter.
- Material: heat-treated steel
- Applications: most pre-1978CB, CL, CT, SL and XL models, XR200 1980-1984, XR200R 1981-1994, XR250L 1991-1994, XR250R 1986-1994.
- Replaces large end of 077160020100 OEM tool



**KA-2952 Spring Hooks**

- Remove exhaust pipe spring, seat or tank holding springs or cotter pins
- L: 220mm (8-5/8")



**KA-5020 Valve Lappers – For hand lapping valves**

- 5020A** has 1-1/8"(29mm) and 1-3/8"(35mm) diameter cups for large valves.
- 5020B** has 5/8"(16mm) and 13/16"(21mm) diameter cups for small valves.



**KA-5033 Valve Stem Seal Pliers**

Pliers reach down around the valve stem into the confined area of the seal to grip it for removal.

"GRIPPING" serration in the tip allow them to grasp both original equipment and aftermarket seals regardless of their configuration.



**KA-5033A Extra Long Valve Stem Seal Ring Pliers**

- For removing valve stem seals in multi-valves engines.
- Jaw longitudinal toothed-avoids slipping down.
- For deeply leveled valve stem seals.



**Multi-Valve**

These tools are purpose to save time necessary when replacing valves in modern 16 to 20 valve heads.

**KA-4183A Multi-Valve, Large Tool**

Work on valves of 4-valve-per-cylinder heads (5.5mm valve stem diameter or larger with under 40 lbs. seat pressure)

**KA-4183B Multi-Valve, Small Tool**

Work on valves of 4 and 5 -valve-per-cylinder heads (5mm valve stem diameter or smaller)



KA-3448 Valve Cotter Tool



KA-3381 Valve Cotter Tool



**KA-4452K Heavy Duty Valve Spring Compressor**

- Used for Car & Motorcycle.
- Designed to compress and release valve spring after removing the collets. Pantograph-type levers ensure a consistent coaxial contact with the valve.
- Driving adaptor 16mm, 19mm, 23mm, 25mm, 30mm

**KA-4452KA Valve Cotter Compressor Tool**

- Remove & Install valve keepers.
- Retainer size: 16, 18, 20, 21 & 24, 27mm (O.D.: 18, 19, 23, 27, 30mm)
- Valve inlet size: Ø5, Ø6

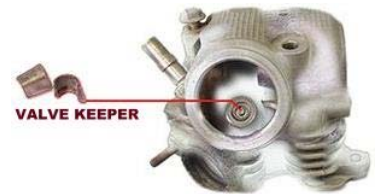

**Operation:**

Remove		Step 1: Cover retainer spring		Step 2: turn the handle and keepers shedding
		Step 1: Keepers put into hole		Step 2: Turn the handle



**KA-3453 Valve Cotter Tappet Piston Spindle Tool**

Tappet Adjust: 8, 9, 10m/m



**KA-2954 Absorber Rubber Ring Pick-Up Tool**





**KA-3505K 39/41 mm Fork Spring Compressor Kit (for Harley-Davidson)**

Designed to install fork caps on forks with large amount of spring pre-load. Will work on most 39mm and 41mm Harley-Davidson fork applications.

**Contents:**

- KA-3505-1 Jackscrew
- KA-3505-2 39mm Adapter
- KA-3505-3 39mm Socket
- KA-3505-4 41mm Adapter
- KA-3505-5 41mm Socket



**KA-3506 39 mm Fork Spring Compressor Kit (for Harley-Davidson)**

Designed to install fork caps on forks with large amount of spring pre-load. Will work on most 39mm Harley-Davidson fork applications.

**Contents:**

- KA-3505-1 Jackscrew
- KA-3505-2 39mm Adapter
- KA-3505-3 39mm Socket



**KA-3507 41 mm Fork Spring Compressor Kit (for Harley-Davidson)**

Designed to install fork caps on forks with large amount of spring pre-load. Will work on most 41mm Harley-Davidson fork applications.

**Contents:**

- KA-3505-1 Jackscrew
- KA-3505-4 41mm Adapter
- KA-3505-5 41mm Socket

**Combination Driver Tool**

- KA-3508A** 3/8" Dr. Square Combination Driver  
- size: 4 Lugs-24mm
- KA-3508B** 3/8" Dr. Square Bearing  
- with 6 Lugs-44mm
- KA-3508C** 3/8" Dr. Square Bearing  
- with 6 Lugs-47mm
- KA-3508D** 3/8" Dr. Square Bearing  
- with 4pcs pins
- KA-3508E** 3/8" Square Bearing and Seal  
- with 4pcs pins and one notch

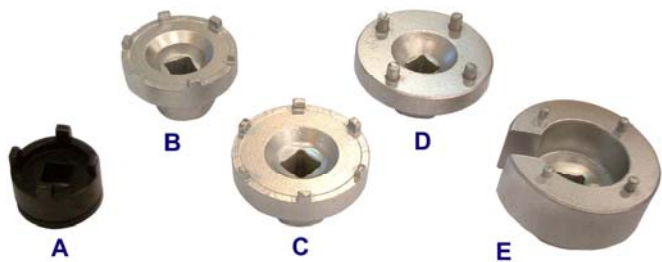

**KA-2984 Clutch Tool**

- Designed to hold clutch baskets, flywheels, gears, sprockets, etc, jaws open up to 5" wide, Made to medium carbon steel with hardened jaws.
- A use-tool for holding any kind of mechanical work.
- Material: Jaw-iron with heat-treated, Body-iron



ITEM NO.	Length	Jaw adjustment	g
KA-2984	10"(305mm)	135mm	725mm





**KA-5090 Plate Pushing Tool**

- To disassemble the clutch
- For professional model
- For VESPA 50/125/150/200 APE



**KA-5091 Plate Pushing Tool**

- To disassemble clutch ring nut
- For VESAP PX - PE



**KA-5092 Fuel Tap Tool**

- For disassemble petrol twist grips
- For all models

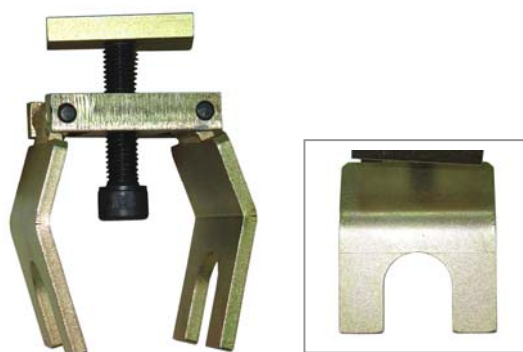

**KA-4180 Drive Shaft Floating Ring**



**KA-4179 Steering Tube Bearing Installer Set**



**KA-4178 Steering Plate Compression Press Set**



**Plate Pushing Tool**

- KA-4181** 20 & 24mm
- KA-4181A** 26 & 30mm



**KA-4182 Handle Threading Tool**



**KA-5109 3/8" Spark Plug Tool Kit**  
With feeler gauges brush  
5/8"(16mm) & 13/16"(21mm) socket



**KA-5110 3/8" Dr. Spark Plug Tool Kit**  
5/8" (16mm) & 13/16" (21mm) socket



**Spark Plug T-Handle W/Magnetic**  
**KA-5235A** 16mm with magnetic & swivel  
**KA-5235B** 21mm with magnetic & swivel



**KA-5111 Flexible Spark Plug Socket Set**  
5/6"(16mm) & 13/16"(21mm)



**Plug Socket Tool**  
**KA-3443** 16m/m x 65L  
**KA-3444** 16m/m x 72L  
**KA-3445** 21m/m x 67L



**Spark Plug Socket**  
**KA-6264** 3/8" x 14 x 90mmL - black finished  
**KA-6264A** 3/8" x 16 x 90mmL - chrome plated



**Spark Plug Socket**  
**KA-6265** 3/8" x 14 x 150mmL - black finished  
**KA-6265A** 3/8" x 16 x 150mmL - chrome plated



**Spark Plug Socket**  
**KA-6266** 3/8" x 14mm x 12PT x 250mmL - black finished  
**KA-6266A** 3/8" x 16mm x 12PT x 250mmL - chrome plated  
**KA-2819** 3/8" x 14mm x 12PT x 250mmL - chrome plated  
**KA-2819A** 3/8" x 16mm x 12PT x 250mmL - black finished



**Tubular Spark Plug Wrench**  
**KA-2904** Ø16MM  
**KA-2905** Ø22.8MM



**12" Spark Plug Extension Bar W/Magnetic**  
**KA-5236A** 3/8"x16mm  
**KA-5236B** 3/8"x21mm  
**KA-5236C** 1/2"x16mm  
**KA-5236D** 1/2"x21mm



**KA-6728 Spark Plug Cleaner**

- Cleans any size of spark plug quickly
- Two-way lever valve allows for blasting or air cleaning
  - Balst action removes carbon build-ups on plugs
  - Internally controlled abrasive blasting
  - Abrasive material supplied
  - Cleans plugs into the new one.



**KA-7001 Spark Plug Wire Tester**

Quickly locate faulty plug wires. No shock hazard. Now you can check spark plug wires without piercing the wires light flashes indicating sound wire.



**PA-A-2013 1-1/2" 13pc Wheel Hub Resurfacing Kit**

Rust build-up on brake rotors can cause warping, and that causes pulsation and diminished braking. This kit attacks the rust on lug studs and rotors on the hub assembly faster and easier than anything you've used before. Usable on most domestic and import vehicles with either front or rear disc brakes. The tool fits you power drill.



**KA-7311K-15M  
15pcs Professional Metric Crowfoot Wrench Set**

Metric Size:  
3/8" DR. 8, 9, 10, 11, 12, 13, 14, 15, 16, 17, 18, 19mm  
1/2" DR. 21, 22, 24mm

**KA-5007-A CV Boot Clamp Pliers**

For Easy Installation of Ear-Type Clamps on Fuel Filters, Water Pumps, Other Cooling System Hose, and CV Joint Clamps.

- Length: 245mm
- Weight: 535g
- Jaw opening: 23mm (max)
- Red Coating Handle
- Can be used with 1/2" SQ. Drive Torque Wrench



**SPARK PLUG HOLE THREAD CHASERS**

These thread chasers clean threads of dirt, carbon build-up and metal particles. Hexagonal section with neoprene band permits use of any standard deep socket. Ends shaped for easy starting.

**KA-3012 Spark Taper - 10 & 14mm**

Use with any standard 13/16" deep socket.



**KA-3013 Spark Taper - 12 & 14mm**

Use with any standard 13/16" deep socket.



**KA-3014 Spark Taper - 10 & 12mm**

Use with any standard 13/16" deep socket.



**KA-3016 Spark Taper - 14 & 18mm**

Use with any standard 13/16" deep socket.



**KA-3015 Spark Taper -14mm**

Features 5/8" hex and 3/8" square drive. Can be used with Extended Spark Plug.



**KA-3206 2pc Lambda Sensor Socket Thread Chaser**

- Used for repairing and cleaning damaged threads on oxygen sensor ports.
- Size:12mm x 1.25, 18mm x 1.5



**KA-5240 Rethreader Kit For 14mm Spark Plugs**

This tool will repair stripped spark plug holes back to a new condition. Kit comes complete with rethreaded tap and one each of four replacement sizes.

**Includes:**

- KA-5240-2 Insert - 3/8" long
- KA-5240-3 Insert - 7/16" long
- KA-5240-4 Insert - 1/2" long
- KA-5240-5 Insert - 3/4" long
- KA-5240-1 Tap and Reamer



**KA-5045 Rethreader Kit For 18mm Spark Plugs**

This tool will repair stripped spark plug holes back to a new condition. Kit comes complete with rethreaded tap and one each of four replacement sizes.

**Includes:**

- KA-5045-2 Insert - 7/16" long
- KA-5045-3 Insert - 1/2" long
- KA-5045-4 Insert - 5/8" long
- KA-5045-5 Insert - 13/16" long
- KA-5045-1 Tap and Reamer



**KA-5046 Rethreader Kit For 14mm Spark Plugs**

This tool will repair stripped spark plug holes back to a new condition. Kit comes complete with rethreaded tap and one each of four replacement sizes.

**Includes:**

- KA-5046-2 Insert - 3/8" long
- KA-5046-3 Insert - 7/16" long
- KA-5046-4 Insert - 1/2" long
- KA-5046-5 Insert - 3/4" long
- KA-5046-1 Tap and Reamer



**KA-6709K 15pcs Metric Rethreader Set**

**Content:**

- 7pc rethreader dies: 6x1.00, 8x1.25, 10x1.25, 10x1.50, 12x1.25, 12x1.5, 12x1.75mm
- 7pc metric rethreader taps: 6x1.00, 8x1.25, 10x1.25, 10x1.50, 12x1.25, 12x1.5, 12x1.75mm
- 1pc metric thread file



**KA-6398 Stud Remover**

Made of heat treated high grade Alloy Steel to loosen hard to turn studs. Compact and powerful. The tighter the stud, the tighter the grip. Capacity from 1/4" to 3/4" (6.35 ~ 20mm) diameter.



**KA-285 Retaining Ring**  
285pc, 18 sizes

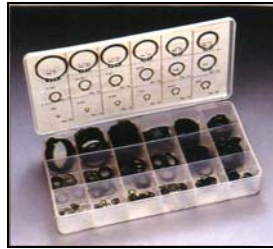

**KA-300 Snap Ring**  
300pcs, 18 sizes

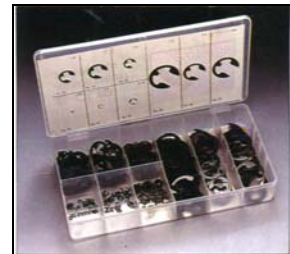

**KA-300E E-Clip**  
300pcs, 9 sizes



**KA-54 O-Ring**  
54pcs, 18 sizes



**O-RING**  
**KA-160M** (Metric)  
**KA-160A** (Inch)  
160pcs, 18 sizes



**O-Ring**  
**KA-225M** (Metric)  
**KA-225A** (Inch)  
225pcs, 18 sizes



**KA-6359 Chain Oil Filter Wrench**  
■ 3/8" & 1/2" dr. cap: 300mm (12")



**Heavy-Duty Filter Wrench**  
**KA-7317A** Cap: 6"(150mm) 1/2"dr.  
**KA-7317B** Cap: 3-3/4"(95mm) 1/2"dr



**KA-2013 Nylon Strap Oil Filter Wrench**  
Use wrench on oil filters up to a 6" (152mm) capacity. Strong nylon belt will not slip. Use with 1/2" square drive tools. 2" Wide



**Oil Filter Wrench**  
**KA-2017** Cap: 85~115mm(3-1/2"~4-5/8")  
**KA-2018** Cap: 60~90mm(2-1/2"~3-1/2")



**KA-76/12-P Filter Disassembling Tool For Piaggio**  
■ 400-500cc 4s Engines  
■ Useful for scored clutches and polygonal cartridges

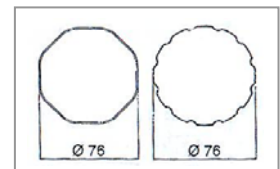

**KA-4271 15pcs Universal Caliper Wind Back Kit**

1:RIGHT HAND HELIX BOLT

2: Citroen/XM, Xantia. (F/R)

3 : Audi (F). FIAT/Alfa Romeo (F). Ford/Fiesta (F). ISUZU (F).

HONDA/Concesto (F.) Jaguar/XJ6,XJ40 (F/R). BMW/318is, 320i, 325TD, 518i, 525i &1x, 740i, 850ci, M5. (F). Mercedes Benz/190,200, 300, 420, 560 series (F).

Mitsubishi/Concesto (F). NISSAN/Mlera, Stanza, Sunny (F). Rover/Austin, Metro, 200 & 400 series, Maestra, Montego (F). TOYOTA/Camry (F). Volvo (F). VW/Passat, Golf GTI (F).

4 : FORD Australia/NZ Telstar, Laser(R). MAZDA (R). SAAB 9000 (R). FIAT/Alfa Romeo 1642.0 (R). HONDA/Prelude, CRS 16i, GM/Saturn (R). GM/Grand Prix, Lumina.

5 : 3/8" dr. Adapter used with extention bar and ratchet when need to apply more strength to the piston.

6 : NISSAN, PRIMERA, VW/GolfIV.

7 : Audi/80, 90, V8+100, Coupe E(R). Rover/800 ABS. SUBARU L+Z(R).

FORD/Sierra ABS, Granada, Scorpio ABS 85(R). NISSAN/Bluebird 1.8 Turbo, Silvia Turbo, Primera 2.0i LS/GS/GSX(R). PEUGEOT/405 1.9 Gi, Gri, Sri, Gtxi, MI 16, 605 2.0 Sri(R). TOYOTA/Celica, Corolla GT MR2(R). VW/Golf Gti, Jeta Synchro, Jetta Gti 16v, Passat CL, GL, GT and GT 16v, Corrado 16V scirroca GTX 16V(R).

8 : GM most 1-7/8" diameter pistons.

9 : GM most 2-1/8" diameter pistons. (CADI Seville/Eldorad 80-85).

0 : GM most 2-1/2" diameter pistons. (Seville/Eldored 79).

A : Renault/R21, Laguna (Rear Disk).

M : Ford Motors Mini Cooper.

N : SAAB. Honda.

F : Opel (Rear disk)



**KA-3060**  
**Disc Brake Piston Spreader**  
Capacity: 0~2 1/2" (0 ~ 65mm)



**KA-3060A**  
**H/D Disc Brake Piston Spreader**  
Capacity: 0~70mm(0~2 3/4")



**KA-5135**  
**Disc Brake Piston Spreader**  
Capacity: 0~70mm



**KA-6676**  
**H/D Disc Brake Spreader**  
Capacity: 0~87mm(0~3-1/2")



**KA-6847**  
**Disc Brake Spreader**  
Capacity:0~48mm(0~1 7/8")



**KA-3060B**  
**H/D Disc Brake Spreader**  
Capacity: 0~70mm



**KA-2997 6pcs 3/8" Dr. Ratcheting Tap and Die Tool Set**

**Productivity:**  
9" Ratcheting are reversible level eliminates had over hand turning



**Access:**  
Used in confined area such as taping engine blocks.



**KA-7187 Brake Spring Tool**

For the removal and replacement of the handbrake retaining spring on Mercedes-vehicles. Applicable for conical and cylindrical retaining springs. Length: 145mm



**KA-3869**



**KA-3869A**

**Brake and Clutch Cable Injector**

(for a motor vehicle)  
This tool is purpose designed to fix the brake and clutch cable when injecting the lubrication oil.

**KA-3869  
KA-3869A**

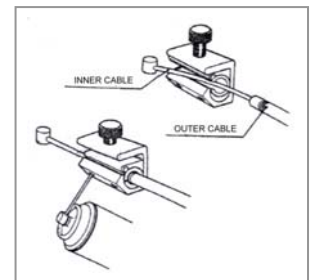

**KA-6500 Headlight Adjusting & Break Spring Hook (6" L)**

Made from heat treated alloy steel. Great for adjusting, removing and installing hard-to-reach adjusting spring. L: 6"(150mm)



**KA-3462 Brake Nut Adjust Tool(14m/m)**



**KA-3475 Brake Line Tool**



**Opening Single Ended Ratchet Wrench— hand with coating cove**

Can be used on pneumatic & hydraulic connections such as brake pipes.

KA-3480A	10mm	KA-3480G	19mm
KA-3480B	11mm	KA-3480H	22mm
KA-3480C	12mm	KA-3480I	24mm
KA-3480D	13mm	KA-3480J	27mm
KA-3480E	14mm	KA-3480K	32mm
KA-3480F	17mm		

**KA-3480K6** 6pc/set 10-11-12-13-14-17mm



**Opening Single Ended Ratchet Wrench— hand satin finish**

KA-3481A	10mm	KA-3481G	19mm
KA-3481B	11mm	KA-3481H	22mm
KA-3481C	12mm	KA-3481I	24mm
KA-3481D	13mm	KA-3481J	27mm
KA-3481E	14mm	KA-3481K	32mm
KA-3481F	17mm		

**KA-3481K6** 6pc/set 10-11-12-13-14-17mm



**Quick Grip Wrench**

- KA-3482 8", 8~17mm
- KA-3483 12", 14~32mm



**KA-3486 6pcs Impact-Driver**



**KA-3484 1/2" Impact-Driver**

- 1/2" x 5/16" socket
- 36L BIT PH2, PH3
- 36L BIT SLOTTED -8, -10
- 80L BIT PH2
- 80L BIT SLOTTED -8



**KA-3485 3/8" Impact-Driver**

- 1-3/8" x 5/16" socket
- 1-3/8" x 1/4" socket
- 2-1/4" x 22L BIT -4, -6
- 3-1/4" x 25L BIT PH1, PH2, PH3
- 3-5/16" x 32L BIT PH1, PH2, PH3
- 2-5/16" x 38L BIT -10-12, -14-16





**T-Handle Sliding Wobble**

- KA-7423** 1/4" 120 x 150mm
- KA-7424** 3/8" 200 x 250mm
- KA-7425A** 1/2" 200 x 250mm



**KA-4176K 10pcs T-Handle & Nut Driver Set (Hex)**

- 5/16" DR. CR-V
- Content:
 

<b>KA-4176A</b> size: 8mm	<b>KA-4176F</b> size: 13mm
<b>KA-4176B</b> size: 9mm	<b>KA-4176G</b> size: 14mm
<b>KA-4176C</b> size: 10mm	<b>KA-4176H</b> size: 17mm
<b>KA-4176D</b> size: 11mm	<b>KA-4176I</b> size: 19mm
<b>KA-4176E</b> size: 12mm	



**T-Handle Socket (Hex)**

- KA-4177A** 8 x 9 x 10mm
- KA-4177B** 8 x 10 x 12mm
- KA-4177C** 10 x 11 x 13mm
- KA-4177D** 10 x 12 x 14mm
- KA-4177E** 12 x 14 x 17mm



**3/8" Dr. Adjustable Extension Bar (CRV)**

MODEL	ADJUSTABLE LENGTH	WEIGHT
<b>KA-7329</b>	7-10", 178-254MM	300g
<b>KA-7330</b>	9-15", 228-380MM	360g

**1/2" DR. Adjustable Extension Bar (CRV)**

MODEL	ADJUSTABLE LENGTH	WEIGHT
<b>KA-7336</b>	7-10", 178-254MM	430g
<b>KA-7337</b>	10-16", 254-400MM	600g



**KA-7342B Multi Drive Angle Sliding T-Handle**

- Can be use for Sliding T-Bar
- Can be Foldable
- Drive angle can be: 75° 90° 105°
- Drive: 1/2" x 3/8" x 1/4"
- Length: 230 x 250mm

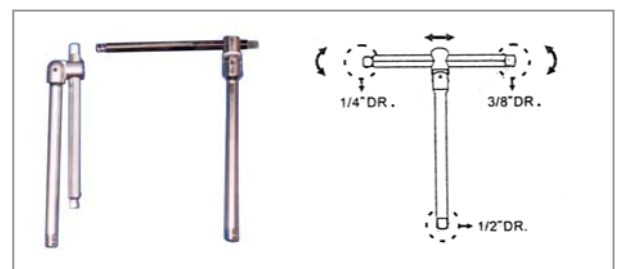



**Sliding T-Handle Socket (CRV) (HEX)**

■ Length: 200x300mm

MODEL	SIZE: mm
KA-7343B	8
KA-7344B	9
KA-7345B	10
KA-7346B	11
KA-7347B	12

MODEL	SIZE: mm
KA-7348B	13
KA-7349B	14
KA-7349B1	17
KA-7349B2	19



**T-Handle Socket (CRV) (HEX)**

■ Length: 200x300mm

MODEL	SIZE: mm
KA-7350	8
KA-7351	9
KA-7352	10
KA-7353	11
KA-7354	12

MODEL	SIZE: mm
KA-7355	13
KA-7356	14
KA-7357	17
KA-7358	19



**KA-7359 3 Way T-Handle Socket (HEX)**

■ Size: 8, 10, 12mm(CRV)

■ Length: 130 x 140mm

■ Content: **KA-7359A** 8 x 10 x 12mm  
**KA-7359B** 10 x 12 x 14mm  
**KA-7359C** 9 x 11 x 13mm



**Foldable Cross Ram Wrench (CR.V)**

**KA-7327C** 16", 1/2" DR. & 17, 19, 21mm

**KA-7327D** 14", 1/2" DR & 17, 19, 21mm



**Sliding T-Handle With Swivel Socket**

■ Length: 200 x 450mm

KA-5088A	6mm	KA-5088F	12mm
KA-5088B	8mm	KA-5088G	13mm
KA-5088C	9mm	KA-5088H	14mm
KA-5088D	10mm	KA-5088I	17mm
KA-5088E	11mm	KA-5088J	19mm



**Adjustable Wobble Extension Sliding T Handle**

**KA-7387W** 3/8"DR 10"~16"(250~400mm)

**KA-7388W** 1/2"DR 10"~16"(250~400mm)

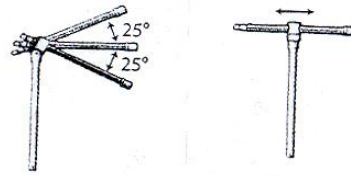

**Adjustable Wobble Extension Bar**

**KA-7326W** 1/4"DR 8"~12"(200~300mm)

**KA-7330W** 3/8"DR 9"~15"(225~375mm)

**KA-7337W** 1/2"DR 10"~16"(250~400mm)



**5pcs Wobble Extension Bar Set**

**KA-5089A** 1/4" DR x 50, 75, 100, 150, 225mm

**KA-5089B** 3/8" DR x 38, 75, 150, 250, 450mm

**KA-5089C** 1/2" DR x 50, 125, 250, 375, 500mm



**5pcs Extension Bar Set**

**KA-6384A** 1/4" x 50, 75, 100, 150, 225mm

**KA-6384B** 3/8" x 38, 75, 150, 250, 450mm

**KA-6384C** 1/2" x 50, 125, 250, 375, 500mm



**KA-5087 1/4"DR Adjustable Wobble Extension Set**

With: 1pc 1/4"dr 7"~12"(175~300mm)

Adjustable extension bar

1pc 1/4"dr mini ratchet handle 6"(150mm)



**KA-5087A**  
1/4" Adjustable Wobble Extension Bar  
■ 7"x12"

**KA-5087B**  
1/4"DR Mini Ratchet Handle 6"



**KA-4198 Axle Nut Wrench**

Ideal tool to install and remove front wheel axles and swing arm pivot shafts. Double sided 19mm and 24mm Hex. It also provides a 3/8" square drive hole in the handle for easy torque adjustments. Works on Honda, Kawasaki, Suzuki, and Yamaha.



**KA-4199 Motorcycle Valve Adjustment Kit**

It makes the valve adjusting easier. Fits most Triumph 500/650/750 twins 1950's - 1970's Fits 7/16 SAE, British 1/4 BS, 3/16 W, 5/16 BS, 1/4 W



**KA-4201 Master Link Pliers**

- Many chains use a "master link", the Master Link Pliers make removal and replacement of these "master links" quick and effortless.
- Insert the jaws into the master link, tighten the forcing screw for squeeze of handles until link is separated.
- Fits on 25, 415, 420, 425, 428 chains.



**KA-4202 Extended Rim Lock Nuts With Beveled Spacers**

- Designed to replace the original lock nut on many motorcycle models with standard rim locks (8mm x 1.25 bolt)
- Extra Length takes less time to remove or tighten and makes operation easier.
- It provides beveled spacers to protect rims.
- Made from 6061 T6 aluminum with 12mm hex head.



**KA-4203 Timing And Crankshaft Turning Tool**

- Ideal tool to turn timing mark on the degree wheel for perfect valve adjustments.
- It makes ignition-timing work to be performed.
- Works on most (1990-present) 750cc, 900cc and 916cc street bike models.
- Notes: Remove spark plugs and place engine in neutral when using this tool.



**KA-4204 Shock Bushing Driver Set**

- Ideal tool for removing bush from shock
- Application: 12.5, 14, 16, 18mm
- Instructions:
  1. Place block on solid bench
  2. Place shock bush over appropriate sized hole.
  3. Use appropriate drift to remove the bush.
  4. Knock bush out shock.
  5. Use copper mallet to avoid damaging the drift.



**KA-4205 Shock Bladder Puller**

This puller threads can reach onto the Schrader valve on the shock reservoir and make the bladder removal be easier.



**KA-4206 Universal Crankshaft Installation Set**

- It is ideal tool for installation the crankshaft into crankcase.
- Fits most single cylinder vertically split engines.
- Set consists of one installing pot, one pot spacer, one bolt with nut and 11 different size adapters.
- All adapters are made from CrMo steel.
- Except for one M12 x 1.25, all adapters have right hand threads.
- Size as follows: M7 x 1.0, M10 x 1.25, M12 x 1.25L, M12 x 10, M12 x 1.25, M14 x 1.0, M16 x 1.0, M18 x 1.0, M14 x 1.5, M10 x 1.25, M22 x 1.0
- For Yamaha YFM200/250/350/400 ATV



**KA-4207 Oil Filter Removal Tool**

- It is ideal tool for removal of many recessed oil filters.
- It is also an essential tool for the removal of KTM oil filters.
- The conical point screw allows user to pierce and grab sheet metal end cap easily. Avoids damaging the engine cases.



**KA-4209 Compression Bolt Removal Tool**

- Ideal tool to remove and install the compression valve assembly from the fork cap.
- It makes operator to properly torque the compression valve assembly during installation.
- 17mm hex head.
- Made from billet 6061 T-6 aluminum.
- Applications: 2007 and 2006 KTM with WP 4860 MXMA CC forks

Caution:

1. Fork cap assembly under pressure. Please wear safety goggles while operating.
2. Depressurize cartridge prior to disassembly.



**KA-4210 Steering Stem Bearing Race Removal Tool**

- It provides a simple way to remove the bearing race on a steering stem.
- It works on most all stems.
- Opening size: 30 ~ 68mm
- Instruction:
  1. Insert it into the stem.
  2. Open it up until it is tight against the stem.
  3. From the other end tap the tool out the lip on the tool.
  4. And then, it will catch the race and pull it through.



**KA-4211 Aluminum Vise Insert**

It is an essential tool for every mechanic's workbench. Aluminum jaws provide three machined openings to hold 5/16" to 9/16" (7mm to 15mm) axles for easy wheel hub and pedal adjustments securely without damage axle threads. The bridge spring keeps the jaws aligned and allows the tool to automatically open.



**KA-4212 Valve Shim Tool**

- Ideal tool when setting valves with shim type adjustment.
- Compresses valve shim bucket for removal of valve adjustment shim
- Applications: Z1/A/B-900, KZ900, KZ1000, KZ1100, KZ1300, ZN1300



**KA-4213 Piston Ring Tool**

- Designed to prevent ring breakage during cylinder installation.
- It can easily remove after cylinder is in position.
- Tool supplied with 4 rings to accept most engine sizes.
- Fits 40 - 85mm.



**KA-4214 Valve Shim Tool**

- Ideal tool when setting valves with shim type adjustment.
- Compresses valve shim bucket for removal of valve adjustment shim.
- Applications: XJ550, XJ650, XJ750, XS750, XS850, XS1100
- Do not use in XZ550, XVZ1200/1300, FJ1100/1200, XT250L and XT/TT350

**Safety Wire Nut And Metric / Imperial Bolt Drill Jig Kit**

Nut Drill Jig allows the safety wire holes to be drilled through the head of bolts or through nuts, across the diagonal easily. It will accept up to a 3.5mm diameter.



**KA-4197A / KA-4197B**

**KA-4197A Safety Wire Nut And Metric Bolt Drill Jig Kit**

- Kit contains one nut drill jig, one metric bolt drill jig.
- Metric Bolt Drill Jig provides 6 drill holes for metric sizes:  
6 x 1.0, 8 x 1.0, 8 x 1.25, 10 x 1.25, 10 x 1.5, 12 x 1.5 bolts

**KA-4197B Safety Wire Nut And Imperial Bolt Drill Jig Kit**

- Kit contains one nut drill jig, one imperial bolt drill jig.
- Imperial Bolt Drill Jig provides 6 drill holes for imperial sizes:  
1/4"-20, 5/16"-24, 3/8"-24, 7/16"-14, 5/16"-18, 3/8"-16 bolts

**KA-4197AB Safety Wire Nut And Metric / Imperial Bolt Drill Jig Kit**

- Kit contains one nut drill jig, one metric and one imperial bolt drill jig.
- Metric Bolt Drill Jig provides 6 drill holes for metric sizes:  
6 x 1.0, 8 x 1.0, 8 x 1.25, 10 x 1.25, 10 x 1.5, 12 x 1.5 bolts
- Imperial Bolt Drill Jig provides 6 drill holes for imperial sizes:  
1/4"-20, 5/16"-24, 3/8"-24, 7/16"-14, 5/16"-18, 3/8"-16 bolts



**KA-4197AB**

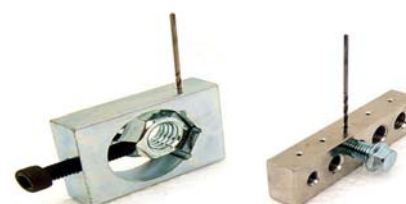



**KA-4208 4pcs FCR Carburetors Tool**

It is an ideal tool for FCR carburetors. It provides 4 tools: 6mm hex for main jets, a 3mm Allen for removing the float bowl and long-reach straight slot for pilot jets. The longer one is an essential tool for reaching into recessed cavities to adjust Keihin FCR carburetors.



**KA-4208A 6mm and 8mm Jet Wrench**

2 sizes in one, 6mm on one end and 8mm on the other end, it fits round jets. Another one with a rubber cap fits 6mm hex jets.



**KA-4196 Carburetor Adjustment Tool**

11" long tool with a 8mm hex nut and screwdriver slot adjusting bolt. The "combo" design that allows unlocking of the locknut, adjustment of the balancing screw and re-locking the lock nut one step. Fits both Keihin and Mikuni carburetors.



**KA-4215 Stud Installation Tool Set**

- Works on most motorcycles cylinder and will not damage stud threads.
- Contains 3 sizes: 6 x 1.0, 8 x 1.25, 10 x 1.25
- Hex head is 3/4" (19mm)



**KA-4216 Swing Arm Bearing Tool**

Designed for installation of the swing arm bearings on Honda, Suzuki, Kawasaki and Yamaha from 1990 through 2000. This tool provides 3 necessary drivers to fit the main swing needle bearings. Allows user to push bearing into the swing arm easily.

Description	Q'ty
Threaded rod	1
Thrust bearing	1
Driver 1 (22.0mm/26.8mm)	1
Driver 2 (21.0mm/26.0mm)	1
Driver 3 (20.0mm/26.0mm)	1
Large washer	1
Small washer	1
Nut	2



**KA-4217 Chain Alignment Tool**

Designed to simplify alignment of the counter shaft and rear sprockets during chain adjustment or wheel installation. Allows the alignment quick and accurate. Champs the square body to rear sprocket so the alignment rod will indicate sprocket alignment to chain.

**Note: the indicator must align the white line. It must be used in the plane place.**



**KA-4219 Rear Kit Installation Tool**

Ideal tool to compress the shock spring for Kawasaki Vulcan 800. Allows operator to remove and install the shock clevis easily.



**KA-4220 Piston Pin Tool**

An essential tool for removing and installing piston pins. It will not damage piston during operation.

Tool includes knurled aluminum handle, 9/16 hex lead screw and three left-handed adapter nuts.

Applications:

Piston sizes: 40mm(1-5/8") to 100mm(4")

Piston pin sizes: 12mm(1/2") to 25mm(1")

Including all single-cylinder engines from 50cc to 600cc and all 2, 3, & 4-cylinder models.

**Warning: Please wear safety goggles when use this tool.**



**KA-4191 Tire Bead Tool <For Motorcycles>**

- It is designed to push the tire bead down into the drop center of the rim without fighting while installing or repairing your off-road tires.
- It holds the tire bead down in the drop center of the rim during tire changes and makes tire changes easier. The securing thumbscrew keeps rims scar-free.
- Material : 6000 series aluminum



**KA-4084 2-Cycle Motor Oil Mixing Tool**

- Measure and mix only what is needed.
- Ratio scale takes the guess work out of mixing oil and gas.
- Complete with extension tube.
- Plastic construction.





HBA-M888

**Wheel Cleaning Stander**

Ideal for polishing & clean wheel.  
Base bottom with rubber keeping stand non-slip.  
For motorbike up to 350 kgs.  
Material: Roller by aluminum alloy



HBA-M888  
HBA-M888R

Dimensions: 23 x 21.5 cm

Dimensions: 23 x 32cm  
With Ramp



HBA-M888R



Rubber keeping stand non-slip



**HBA-M889 Bike Glide Buddy**

- 360° moving.
- Heavy duty constructions work on any bike.
- Low profile design allows bike to roll on and off easily.
- Kit will glide in any direction.
- Great for moving motorcycle in tight spaces.
- Rolls easily on concrete and asphalt surfaces.



360° moving

**KA-2100 2L Oil Drain Pan**

- Catches the engine waste oil when changing the Motorcycle's engine oil.
- Convenient
- Easy to use
- Environmental protection

- ✓ The front side opening design for easy dumping of all oil collection.
- ✓ Capacity: 2 liters





**KA-4046 Chain Clamp Pliers for Motorcycle**

- Designed to easy installation and removal of clip-type master chain links.
- Suitable Chain #428 and #420



**Motorcycle Chain Puller**

- Designed for work on drive chains found on motorcycles and all-terrain vehicles (ATVs).
- Specification size max. 45mm
- Suitable chain #428 and #420

**KA-4048**

surface: chrome finished

**KA-4048A**

surface: black finished with red screw nut

**KA-4048B**

surface: black finished with satin finished screw nut

**Operation:**

Fit tool jaws in chain link ends, tightening the forcing screw pulls the jaws together to hold the chain for easy removal or installation of the chain connector or master link.



KA-4048



KA-4048A



KA-4048B

**KA-4056 Master Link Pliers**

- Many derailleur chains use a “master link” that allows the chain to be replaced by hand, but over time, wear, dirt and corrosion can make it difficult to separate by hand.
- This tool can solve the problem and make removal and replacement of these master links quick and effortless.
- Insert the jaws into the master link and squeeze the handles until link is separated.



**KA-4047 6pcs Piston Ring Clip For Motorcycle**

- Size: 35~41mm (1-3/8" ~ 1-5/8")in.  
 41~47mm (1-5/8" ~ 1-27/32")in.  
 47~53mm (1-27/32" ~ 2-3/32")in.  
 53~59mm (2-3/32" ~ 2-5/16")in.  
 59~65mm (2-5/16" ~ 2-5/8")in.  
 66~73mm (2-5/8" ~ 2-7/8")in



**Clutch Nut Wrench**

It can be used for removing and replacing the clutch nut



**KA-3361A**

- 41 x 34mm
- With 3/8" driver and 19mm socket
- Suits to Yamaha and Suzuki

**KA-3361B**

- 32 x 39mm
- With 3/8" driver and 21mm socket
- Suits to Honda and Suzuki



**KA-3362 Fork Cap Wrench – multi size**

- It provides three sizes and fits a variety of sport bikes.
- Size: 24, 32, 41mm



**KA-4076 Fork Cap Wrench- for KTM 48mm WP**

This 4 pins spanner wrench is ideal tool to loosen the KTM 48mm WP fork caps without removing the handlebars.



**KA-4077 Fork Compression Valve Removal Tool**

- Ideal tool to remove the compression valve from cartridge.
- 19mm drive hex with 36mm octagon.
- Made from 6061-T6 aluminum.
- Application: Yamaha: YZ 125/250 05-06, YZ 250F/450F 06-08  
Honda: CRF250R 2010, CRF 450R 2009



**KA-3368 Showa BPF Fork Cap Removal Tool**

For removing aluminum fork cap on showa BPF 43mm forks. It fits 45mm fork cap hex.



**KA-3370 KYB Twin-Chamber Compression Tool**

This tool works on the Twin-Chamber KYB forks and is designed to remove the compression body from the cartridge.





**KA-3373 Fork Bleeding Tool Set**

It can easily thread onto the damping rod to facilitate cartridge fork bleeding and prevent the typical mess when changing fork oil. Set provides adapters for 10mm x 1.0mm, 12mm x 1.0mm, 12mm x 1.25mm and 14mm x 1.0mm damping rods.



**KA-3374 Fork Compression Damping Adjuster Tool**

This adjusting tool is flat and has a tip on the bottom so it easily fits between the handlebar and top of the fork tube on almost all setups.



**KA-3375 Fork Cap Tool**

Ideal tool to remove and install the fork cap. Fits most "OHLINS" suspension models. There is a square hole on the backside for a 1/2" drive. The rubber cushion design allows you without damaging the fork cap while using. Material: 7075-T6 aluminum



**KA-5197 Wheel Bearing Removal / Installation Tool**

**For Harley-Davidson**

- It is ideal tool to remove and install sealed type wheel bearings without damaging the wheel.
- It can be used on 3/4" and 1" I.D. bearings 2000-2006 and 25mm bearings on most 2007-2008 models with or without ABS.



**KA-2227 Motorcycle Side Stand**

- Lift the motorcycle tire above the ground and make the repair and maintenance jobs such as chain ring, tire and frame.
- The motor bike swing arm must have lift point or swing arm spool which support U shape or L shape rack.
- Quick lock mechanism. Easy to use and can be operated by hands.
- Support the wheel frame from 12-21 inch
- Adjustable Range: 230-280mm
- Total length: 285mm
- Weight: 285g





**KA-2224 Steering / Fork Cap Wrench For Motorcycle**

- Allows access with handle bar in place.
- 12 point design for easier tool placement.
- 30-32mm Wrench Size



**KA-3377 Shock Preload Adjusting Tool**

It is ideal tool for adjusting preload without damaging the rear shock spring collars. The "bent tip" adjusts spring collars in difficult to reach places.



**KA-3378 Shock Seal Head Installation Tool Set**

These tools protect the shock shaft seal when installing the seal head onto the shaft. They make seal head easy and quick removal and installation of seal assemblies. Set provides five sizes: 12.5 x 10mm, 14 x 12mm, 16 x 12mm, 18 x 16mm, 18 x 12mm



**KA-3379 Shock Compression Adjuster Removal Tool (socket YZ)**

It allows easy removal of the rear shock compression adjuster.  
Note: The punch marks at the threads must be drilled 1mm deep prior to removal.



**Shock Compression Adjuster Removal Tool**

It allows easy removal of the rear shock compression adjuster.  
Note: The punch marks at the threads must be drilled 1mm deep prior to removal.



KA-3390A



KA-3390B



KA-3390C

		
<b>KA-3390A</b> 24mm	<b>KA-3390B</b> 9mm	<b>KA-3390C</b> 21mm



**KA-3391 Damping Rod Tool**

Allows the damping rod to retrieve effortlessly after spring installation. Works on Kayaba, Showa and WP inverted forks.

Tool provides one rod w/M10 x 1.0 end and four brass hex adapters are included M10 x 1.0, M12 x 1.0, M12 x 1.25 and M14 x 1.0



**KA-4049 Cartridge Rod Holding Plate**

- Perfect for disassembly and assembly of KYB / Showa Twin Chamber and most street cartridge forks.
- Designed to hold back the spring allowing you to loosen or tighten the bottom nut or the fork cap on the cartridge rod.
- Fits 10 to 12.5mm rods.



**KA-4050 Parking Brake Piston Socket – for Suzuki**

Material: Heavy duty CR-MO steel construction.



**KA-4051 Parking Brake Piston Socket – for Yamaha**

Material: Heavy duty CR-MO steel construction.



**KA-2439A Motorcycle Brake Bleeder**

- Aids in the bleeding and servicing of hydraulic brakes.
- It allows user easy to make bleeding brakes by oneself.
- The unique check valve design makes fluid and air to escape while preventing air from re-entering the system.

**KA-4052K Front and Rear Wheel Nut Tool Set – for Ducati**

Set provides one combined socket and 4 sockets. It also provides 3 O-rings for replacement. The combined socket (KA-4052A) is two sizes in one, a 55mm 12pt for the rear and a 28mm 6pt for the front.



The other sockets size as follow:  
 KA-4052-01 41mm 6/12pt for the rear wheel  
 KA-4052-02 46mm 6/12pt for the rear wheel  
 KA-4052-03 30mm 6pt, for the front wheel  
 KA-4052-04 28mm 12pt, for the front wheel  
 All sockets with 1/2" drive.  
 Material: 7075-T6 aluminum with black anodizing

The 30mm 6pt (KA-4052-03) and 28mm 12pt (KA-4052-04) socket can be fitted into the combined socket, as shown in the picture. You can use them fit together or separate.



**KA-4052A-30 Front and Rear Wheel Nut tool**

It provides 2 sockets with 1/2" drive.  
 One combined socket(KA-4052A) for front and rear wheel nut. It is two sizes in one, a 55mm 12pt for the rear and a 28mm for the front. Another one(KA-4052-03) is 30mm for the front wheel.  
 Fits Ducati 1098/1198/streetfighter or multistrada 1200, 748, 916, 998, 996, Hypermotard, Multistrada, All Monsters, Supersports, Sport classic.  
 Material: 7075-T6 aluminum with black anodizing.  
 Suggestion: Instert 30mm socket into the combined socket for storage when service is finished.



**KA-4053 Rear Axle Alignment Tool**

It is essential tool proper axle alignment  
 The 90-degree angle and adjustable pointer design allows operator to rest it in the swing-arm pivot and axle.



**Instructions:**

1. Loosen rear axle nut, put the 90° angle end in swing-arm pivot bolt.
2. Loosen adjustable pointer and move it to end of rear axle. Tighten screw.
3. Transfer the tool to the other side of motorcycle and put the 90° angle end is swing-arm pivot bolt again. Do not readjust pointer.
4. Adjust the axle until both sides measure the same distance.
5. Adjust chain adjusters for proper chain tension.



**KA-4054K Spoke Torque Wrench set**

The spoke torque wrench set allows you to care for your wheels, true and maintain the desired tension of your spokes.

It provides four wrenches, the following sizes are included in the set:  
 No.1: 5.6mm, 5.7mm, 6.0mm, 6.3mm, 6.6mm, 6.8mm  
 No.2: 5.0mm, 5.4mm, 5.8mm, 6.2mm, 6.4mm, 7.0mm  
 No.3: 5.1mm, 5.5mm, 6.1mm, 6.5mm, 6.7mm, 6.9mm  
 No.4: 4.0mm, 7.1mm, 7.4mm, 5.6mm, 6.0mm, 6.2mm





**KA-4055 Cylinder Head Nut Torque Tool – 14mm, 15mm**

- These tools enable you to properly torque the 14mm and 15mm cylinder head nuts.
- There is a square hole on these tools for a 1/2" drive.
- 15mm torque tool fits on all modern 2V and 4V Ducati's (Monster, Multistrada, 748, 749, 750, 851, 888, 900, 916, 996, 998, 999, 1000)
- 14mm torque tool fits on the newer 4V Ducati's (600, 620, 848, 1098, 1198 and Similar)

**Suggestions:** Always use these tools at right angles to the torque wrench; this preserves the proper torque value. Make reference to the service manual for your bike model before use.



**KA-4057 ATV Steering Knuckle/Ball Joint Separator**

- It consists of a tool body and both types of press bolts to fit Honda and Yamaha.
- It allows you without damaging the A-arm, ball joint studs or rubber boots while separating the ball joints from the knuckle body.
- It works on the following ATV models:  
**Honda:** TRX250R 86-89, TRX250X 87-88/91-92, TRX250 Recon 97-01, TRX300EX 93-01, TRX450R 04-07, TRX450ER 06-07  
**Yamaha:** YFZ350 87-01, YFM350X 87-01



**KA-4058 Foot Break/Shifter Bolt Removal Tool**

For Ducati Desmosedici RR

- Ideal tool to prevent damage to the bolts or your bike while removing the foot break/shifter bolts.
- Tool has a 1/2" drive.



**KA-4059 Drive Gear Removal Tool**

For Ducati

- The distributor drive gear is held in position by the KM3 nut, this tool can actually get to the lock washer, making the removal easier to perform.
- It fits Ducati Roundcase 750 sport, 750GT, 74SS and others with KM3 nuts.



**KA-4060 Cam Pulley Nut Tool**

For Ducati

- It fits Ducati Pantah and other 2 valve belt drives, as well as 4 valve 916 belt drives.
- Tool provides one holding tool and one socket tool with 1/2" drive.
- The holding tool allows you to hold the camshaft timing pulley from rotating and the socket tool to loosen and tighten the cam pulley retaining ring nut.





**KA-4061 Engine Rotating Tool**

For Ducati



- It allows you to rotate your engine easily and safely while checking the valve clearances or setting the timing.
- It works on Monster / 748 / 996 / 999 / SS



**KA-4062 Alternator Cover Puller**

For Ducatil



- It is essential tool to remove the left hand side cover on Ducati Engines.
- Puller provides one tool body (made from 6061 aluminum) and comes with 3 bolts (M10 x 1.25 x 50L-1pc, M6 x 1.0 x 30L-2pcs)
- It fits 1990-2009 Ducati Models 600/ 620/ 695/ 696/ 748/ 749/ 750/ 800/ 848/ 851/ 888/ 900/ 906/ 907/ 916/ 996/ 998/ 999/ 1000/ 1078/ 1098/ 1100/ 1198



**KA-4063 Clutch Hub and Drum Tool**

For Ducatil



It is designed to hold both clutch basket and hub while removing both of these items. It allows you to assemble the R&R clutch in safety, especially if you are installing an aftermarket clutch basket. The tool must be held while trying to remove or install the hub nut or the clutch basket cap screw. So this tool is equipped with a tang and a long bolt that allows you to fit it to one of the bolt locations that are present after you remove the clutch cover. It will work with all modern 6 speed Ducati's equipped with a dry clutch. Material: Polyamides (PA) with fiber.



**KA-4075 Ducati Bevel Twin Sprocket Nut Socket & Nut**

Designed for tighten the sprocket ring nut on a Ducati Bevel Drive Twin. This tool is a set, with a new nut.





**KA-4064A Ducati Camshaft Alignment Tool**

18 tooth sprocket

- It fits the 851, 888, 916 and 996 engines.
- It allows you to keep the camshaft sprockets correctly aligned while installing of new cam belts.
- It also helps you to remove the nut attaching the pulley to the camshaft.
- Install the tool with lobes on the camshaft with the nut to be removed.
- Use a spanner socket to remove the nut.
- Material: Aluminum 6061



**KA-4064B Ducati Cam Belt Lock Tool**

18 tooth sprocket

- It fits 748, 916, 996 and Desmoquattro.
- It helps you to hold the loaded cam from rotating while installing the belts on 4 valve Ducati engines.
- It will not fit st4 or s4 engine.
- Slide the tool between the cam belt pulleys and slide the old belt off.
- Material: Aluminum 6061.



**KA-4064C Ducati Short Cam Belt Lock Tool**

20 tooth sprocket

- It helps you to hold the loaded cam from rotating while installing the belts on 4 valve Ducati 749/ 999 Testastretta engine.
- Slide the tool between the cam belt pulleys and slide the old belt off.
- Material: Aluminum 6061.



**KA-4065 Top Yoke Ring Nut / Steering Stem Nut Tool**

For Mv Agustga

- It is an essential tool for removing top yoke ring nut, steering stem nut and steering head when you are greasing the stem bearings.
- It is also helpful tool to periodically make sure it is tight.
- Because it is made from aluminum, it will not damage your bike parts while working.
- Featuring a 3/8" square drive.
- It fits Mv Agusta Brutale, Mv Agusta Brutale 910, Mv Agusta F4 1000, and Mv Agusta F4 750.



**KA-4066 Steering Stem Nut Tool For Ducati**

- It enables you to correctly torque the steering stem nut.
- It is designed to be used with a 3/8" drive.
- It fits all 4V superbikes, Multistrada, Hypermotard and other models with the large diameters steering stem nut.
- The rubber cushion design allows you without damaging the steering stem nut in the process of removal and installation.
- Material: 6061-T6 aluminum.





**KA-4067A Front Axle Alignment Tool For Ducati, 30mm ID**

- This tool allows you to help install and maintain correct alignment of the front axle while the axle nut is being tightened.
- Fits Ducati 848, 1098, 1198 and other models that use a 30mm ID axle.
- Material: Aluminum 6061 T6



**KA-4067B Front Axle Alignment Tool For Ducati, 25mm ID**

- This tool allows you to help install and maintain correct alignment of the front axle while the axle nut is being tightened.
- Fits Ducati 748, 916, 996, 998, 749, 999, ST2, ST3, ST4, 620SS, 800SS, 1000SS and other models that use a 25mm ID axle.
- Material: Aluminum 6061 T6



**KA-4067C Front Axle Alignment Tool For Ducati**

- This tool allows you to help install and maintain correct alignment of the front axle while the axle nut is being tightened.
- Fits for All Ducati that have Ohlins forks and a 25mm inside diameter axle. It also fits the Hypermotard.
- Material: Aluminum 6061 T6



**KA-4068 Timing Plug Wrench**

- It fits the straight-slot timing plugs on most motorcycles and ATVs.
- Blade size is 22mm(7/8")



**KA-4069A Ducati Head Timing Tool 1000M/03**

- Belt roller timing of two-valve head.
- It fits most Ducati motorcycles.
- Size: M8 x 1.25 + M5 x 0.8

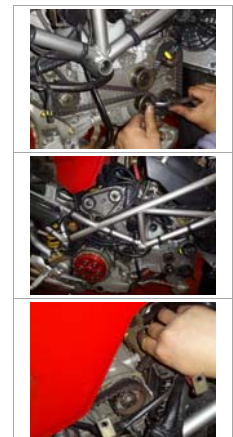



**KA-4070 Wheel Bearing Locking Ring Tool**

For Triumph

- It is designed to remove and install the lock rings that hold in the wheel bearings on most models.
- Material: stainless Steel



**KA-4071 Triumph Clutch Spring Nut Tool**

- It is a handy tool that helps you to adjust the clutch pressure plate springs simple.
- Measures 3" long.



**KA-4072 Primary Chain Adjusting Tool**

For Vintage Triumph 500/650/750cc

- It fits most of the unit twin T100, T120, TR6, T140 and TR7 models.
- The size and shape of this tool fits into the rear adjusting hole without removing pegs or levers.
- Turn the end with a screwdriver blade for ease of adjusting.

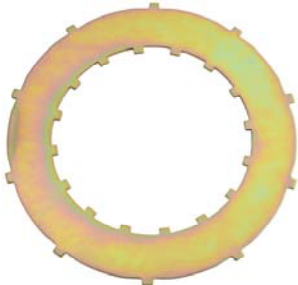

**KA-4073 Clutch Locking Tool**

For Triumph and BSA

- This tool helps you to lock the clutch drum and center together for easy tightening as well as removal of the clutch center nut.
- A helpful tool for any primary or clutch work you need to do, or if you need to remove your clutch basket while rebuilding your gear box or entire motor.
- Models supported include the BSA A7, A10(the late 4 spring clutch), A50 and A65(4 spring clutch), Triumph 500/ 650/ 750cc twins.



KA-2079

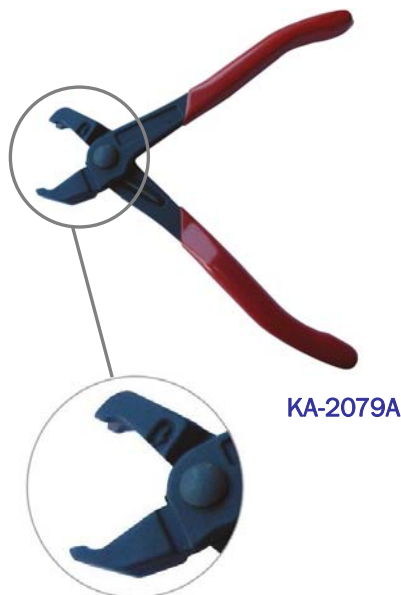

KA-2079A

**Chain Pin Remover/Installer Plier**

**KA-2079 KA-2079A**

For remover and installer chain pin.  
Slim jaw design can clip chain pin easily.

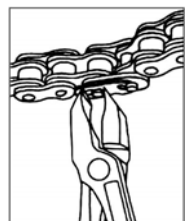



**KA-4195C Motorcycle Hex Axle Tool (6 in 1)**

- Six stepped sizes: 12, 14, 17, 19, 22, 24mm
- 3/8" square drive on both ends. Can also be used with socket.
- Fits internal hex axle on most modern motorcycles, including:  
 Buell: XB9R, XB9S, XB12R, XB12S (2003-2004)...  
 Honda: CBR600RR, CBR1000RR...  
 Kawasaki: ZX6R, ZX6RR, ZX600E/K, ZX7R, ZX9R, Z1000, ER-6N, Versys 650...  
 Suzuki: GSXR 2000-2007, DL 1000 V-Strom (all), SV 1000...  
 Yamaha: R1, R6, XT6600Z...  
 Also useful for BMW, KTM, etc.



**4-in-1 Hex Axle Tool (for Sport bikes)**

**KA-4195A** Material: 7075-T6 Aluminum, for strength-weights are extremely light. Ideal for touring or off-road tool kit.

**KA-4195B** Material: CRMO steel, Heavy duty, for shop use.



**KA-4195A**



**KA-4195B**

This tool fits into the internal hex on many late model sport bike axles and some dirt bikes.

It provides four metric hex sizes: 17, 19, 22, 24mm

3/8" square drive on both ends and works with any 3/8" drive wrench.

Do not exceed 90 ft-lb(122 Nm) torque on this tool. It may cause tool to fail resulting in injury to user and damage to the equipment.

Buell: XB9R, XB9S, XB12R, XB12S (2003-2004)

Honda: CBR600RR, CBR1000RR

Kawasaki: ZX6R, ZX6RR, ZX600E/K, ZX7R, ZX9R, Z1000

Suzuki: GSXR 2000-2007, DL 1000 V-Strom (all), SV1000

Yamaha: R1, R6

**KA-4078 Damper Rod Fork Tool**

- Ideal and perfect tool to assemble and disassemble of most 41, 43, 46 and 47mm Kayaba and Showa inverted forks.
- Not needed for 91/92 Honda CR models.
- Replaces the following tools where the manufacturer recommends : 07PMB-KZ410A and YM-1423.



**KA-6881 Valve Adjustment Tool**

This tool helps you to adjust valve easily.

**Application:**

Honda : Dax 50/70, Monkey Z50, CB/CY50, CM185-250, CB250RS, XL250 S/R, CL250S

Yamaha : XT250, SR250, XT500, SR500, XT500/600, SPX600, XS650/650SE,

Suzuki : Bandit, GSX





**KA-4079 Primary Gear Wheel Bracket**

A special tool for primary gear wheel.  
It fits KTM.



**Valve Shim Measuring Tools**

Work on all engines using 8mm or 7mm valves.  
Sold as a pair, one is for measuring the closing shim; the other is for opening shim.

**KA-4080A** 8mm

**KA-4080B** 7mm



**KA-4081 8mm (5/16") Valve Guide Drift Tool**

This tool provides a safe and easy way to remove and install valve guides without damaging the cylinder head.  
It fits Norton, BSA and Triumph bikes.  
Material : T-6061 aluminum



**KA-4700A Clutch Spider Nut Driver**

- It is essential tool when servicing or re-building a Polaris clutch.
- It fits P85 and P90 primary clutches on all **Polaris** ATVs and snowmobiles.
- It also fits **Kawasaki** 300 & 400 Prairie 2x4 and 4x4, 99-02 models.



**KA-4700B Clutch Spider Nut Driver**

- It is essential tool when servicing or re-building a Polaris clutch.
- It fits P85 and P90 primary clutches on all Polaris ATVs and snowmobiles.



**KA-4701 A-Arm Needle Bearing Press Tool**

- It fits **KTM** ATV 450/525 series.



**KA-4702 Steering Bearing Press Tool**

- It fits **KTM** ATV 450/525 series.



**KA-4703A Primary Drive Clutch Puller**

- Clutch puller for **Polaris** ATV 02-08 sportsman 600/700 twin EFI X2.
- 3/4" - 16 rolled thread, 10 - 1/2" total length



**KA-4703B Primary Drive Clutch Puller**

- Clutch puller for **Polaris** ATV 02-08 sportsman 600/700 twin EFI X2.
- 3/4" - 16 rolled thread, pusher pin 4 - 5/16" long



**KA-4706 Press Tool For Rear Ex-centric**

- For use on **KTM** **ATV** 450/525 series.



**KA-4536ML Master Link Pliers**

- Uniquely Special designed pliers for installing and removing the master links.
- One side has groove and a bit longer than the other, so it latches on mater links easily and securely.





**KA-4707 ATV Swing Arm Tool**

- It is a 2 in 1 tool.
- One end is for removing and reinstalling the pivot bolt lock nut, the other end is for removing the pivot bolt.
- It fits most all 4-stroke **Honda** 4 Wheelers



**KA-4708 ATV Pinion Nut Tool**

- This pinion nut tool fits **Kawasaki** KVF360/650/700/750 series.
- 1/2" square drive.



**Pinion Bearing Nut Tool**

This tool is designed for removing and reinstalling the pinion bearing nut in **Honda** **ATV**.

**KA-4709A 64mm Pinion Bearing Nut Tool**

- It fits TRX250/350/400/420/450/500/650/680.

**KA-4709B 60mm Pinion Bearing Nut Tool**

- It fits early ATC, TRX250/300/350.



**KA-4710 Water Pump Drive and Rotor Service Tool**

Multi-purpose tool for helping to remove and install the water pump drive gear on the rotor and to remove the rotor from the crankshaft.

- It fits **Polaris** ATV, Side x Side and also works on RZR XP.



**KA-4703C Primary Drive Clutch Puller**

- A compact design helps you to service clutch without removing the fuel tank.
- It works on all **Polaris** Ranger & RZR UTV and Sportsman ATV models. **NOT RZR-XP 900**

*NOTE: It is not necessary to pull or remove the primary clutch if you are only servicing / changing the weights and spring.*





### KA-4711 Ball Joint Replacement Tool

- Used to remove and install the lower ball joints on **Polaris ATV and side x side** models with pressed-in ball joints on the front strut casting.
- Tool includes one ball joint install adapter, puller plate, receiving cup, forcing screw, 3/4"-16 x 16L x 28H nut, two 1/4"-20 x 70L screws and two 1/4"-20 x 50L screws.



### KA-4712 Drive Clutch Fixture

- This fixture helps you to hold the stationary sheave when removing the spider on **Polaris** ATV and **RANGER** drive clutches.
- It provides three M12x1.75x15mm cap screws for use with the **Yanmar** diesel drive clutch.



### KA-4713 Universal Clutch Compression Tool

- This tool provides a quick and effective way to compress the drive or driven clutch without binding during assembly or disassembly.

**Applications:**

All **Polaris** full-sized models ATV, Side x Side and Snowmobile drive clutches. **Polaris** and **TEAM** clutches.



### KA-4714 Shock Spanner Wrench

- Fits **Honda** MX/ACT 200/250/250R/350X
- Fits 68mm/87mm lock rings with a 8mm notch and many street, off-road and ATV single shock applications.



### KA-4715 ATV Clutch Puller Tool

- Clutch Puller for Honda Models.
- Tool has both male and female threads so you can use either end for installs.
- It works on a variety of Honda 4 stroke ATV models.

## Clutch Puller



Item No.	Size	Application
KA-4705-01	M18 x 1.5	All <b>Yamaha</b> 4 strokes, 84-94 PZ480, 94-99 V-Max 500/600/700, 00-06 SX/SXR/Viper/Venom
KA-4705-02	M14 x 1.0	<b>Ski-doo</b> liquid twin 443/454/494/583/617/643 1990-1999 and fan cooled twin 440/503 1997-2001
KA-4705-03	M14 x 1.5	<b>Ski-doo</b> 99-15 two stroke/four stroke, 95-01 triples, 93-99 670 twin
KA-4705-04	M14 x1.0	<b>Ski-doo</b> 583 clutches.
KA-4705-05	M14 x 1.5	<b>Polaris</b> all U.S. Twin models 1997-99 (except 440 XC Edge 99)
KA-4705-06	M14 x 1.5	<b>Arctic Cat SXS</b> : 700 Wildcat Trail 14, 1000 Wildcat 4 2013-14, 1000 Wildcat X 2013-14 <b>Arctic Cat Snowmobile</b> : 1,000cc 2 stroke 2007-09, 1,100cc 4 stroke 2007-09, All models 2010-13
KA-4705-07	M14 x 1.5	For newer <b>Arctic Cat</b> snowmobiles
KA-4705-08	M18 x 1.5	<b>Yamaha</b> YPZ/YXR clutches all years
KA-4705-09	3/4" – 16	<b>Polaris</b> Indy series, 1988-89 Longtrak Reverse, 1986-87 Sprint 340, 1986-87 Sprint 340 ES, 1988/90 Sprint ES 339cc, 1985, 1987-90 Star, 1993-95 Starlite and 1988-90 Startrak
KA-4705-10	M20 x 1.5	<b>Yamaha</b> 1978-88 EC340 series, 1979 EX440C, 1981 EX440E, 1980 SR540D SRV, 1980 SRX440D
KA-4705-11	M18 X 1.5	<b>Yamaha</b> YPZ and YXR, 85-86 Excel V, 85-86 Phazer, 85-86 SRV, 85 SS440, 92-93 V-Max 4, 97 V-Max 500, 600, 700.
KA-4705-12	3/4" – 16	<b>Polaris ATV/UTV</b> : 900 RZR S 4x4 15, 900 RZR XC 15, 900 RZR 4x4 15, 900 RZR XP 4x4 11-14, 900 RZR XP 4 4x4 12-13, 900 Ranger XP 13-15, 900 Ranger Crew 14-15, 1000 RZR XP 4x4 14-15, 1000 RZR XP 4 4x4 14-15 <b>Polaris Snowmobile</b> : 4 stroke models 2006-08, 440 XC Edge 1999-03, 700 XCR 1993-03, 800 XCR 1999-03, all models 2010-13, all U.S. Twins 2000-09
KA-4705-13	5/8" - 18	<b>Ski-Doo</b> : Most 1976-85 and 1986-93 models using square shaft clutch with standard thread. <b>Polaris</b> : 1965-1972 models with steel clutch.
KA-4705-14	M14 x 1.0	1986-up <b>Ski-Doo</b> TRA Clutches with 25mm crankshaft taper and 3/4" (19mm) head bolt, except models with 599, 670, 699, 779, and 809 engines
KA-4705-15	M18 x1.5	All <b>Kawasaki</b> built snowmobile clutches.
KA-4705-16	3/4" – 16	<b>ATV/UTV:</b> <b>Polaris</b> : all Models 85-12 except 900 RZR XP 4x4 11-12, 900 RZR XP 4 4x4 12, 550 Sportsman XP 4x4 09-12, 550 Sportsman all models 10-12, 570 RZR 4x4 12, 800 RZR 4x4 all models 08-12, 850 Sportsman XP 4x4 09-12, 850 Sportsman all models 10-12 <b>Snowmobile:</b> <b>Comet</b> : 100C/102C/108C/108EXP <b>Polaris</b> : 340 Classic/Deluxe/Touring 1999-06, 500 Indy/Classic 1999-06, 600 Triumph/Widetrack LX 1996-06, all models through 1998
KA-4705-17	1"-12	<b>Polaris</b> all secondary clutches 1985-05