

KA-6719KN Diesel Engine Compression Tester Kit

- Comprehensive test kit for both direct and indirect diesel injected cars.
- Simple & easy to use.
- For use on both direct and indirect injection engines.
- Checks engine compression under cranking conditions.
- Small profile, quick coupling adapters for speed & security
- Built-in pressure relief valve enables repeat tests without dismantling.
- Flexible hose (355mm) gives access to restricted plug & injector ports.



DESCRIPTION		OVERALL LENGTH	GAUGE DIAMETER	SCALE
A	GAUGE ASSEMBLY	560MM	83MM	0-70BAR (0-1000PSI)
B	CENTRE PILLAR	LENGTH	INT. THREAD	EXT. THREAD
		165	M8x1.25	1/2x20UNF
C	SPACER SET	LENGTH	INT. DIAMETER	EXT. DIAMETER
		38.3	17	20.1
		25.6	17	20.1
		19.1	17	20.1
		12.65	17	20.1
		6.6	17	20.1
D	END ADAPTER	LENGTH	INT. THREAD	EXT. DIAMETER
		30	1/2x20UNF	21
		32	1/2x20UNF	24
F	END ADAPTER	41.5	1/2x20UNF	24
G	90° ELBOW			
H	CLAMP PLATE	LENGTH	WIDTH	HOLE DIA
		78	25	17
		64	25	17
I	CLAMP PLATE			
J	REPLACEMENT SEAL AND WAHSEK SET			

KA-6720KN Diesel Engine Compression Tester Set (Cars)

Comprehensive test kit for both direct and indirect diesel injected commercial, marine and industrial engines.

- Simple & easy to use.
- Checks engine compression under cranking conditions.
- Small profile, quick coupling adapters for speed & security
- Built-in pressure release enables complete test without dismantling.
- Flexible hose (355mm) gives access to restricted space.

©APPLICATIONS

BMW, HOLDEN, NISSAN, VAUXHALL, CARBODIES, ISUZU, OPEL, VOLKSWAGEN, CITROEN, LAND ROVER, PEUGEOT VOLVO, DACIA, LEYLAND/DAF, RENAULT, DIAHATSU, MAZDA, ROVER, FIAT, MERCEDES-BENZ, SEAT, FORD, MITSUBISHI, TOYOTA



DESCRIPTION		OVERALL LENGTH	GAUGE DIAMETER	SCALE
A	GAUGE ASSEMBLY	560mm	83mm	0-70 BAR (0-1000PSI)
B	GLOWPLUG ADAPTER	OUTSIDE DIA	LENGTH	THREAD
		14H	74	M10X1.25
C	GLOWPLUG ADAPTER	5/8H	54	M12X1.25
D	GLOWPLUG ADAPTER	19H	72	M14X1.25
E	DUMMY INJECTOR	Ø21	114	N/A
F	DUMMY INJECTOR	27H	65.5	M24X2.0
G	STANDYNE DUMMY INJECTOR	Ø19	112	N/A
H	GLOWPLUG ADAPTER	12H	114	M10X1.25
I	GLOWPLUG ADAPTER	12H	119	M10X1.0
J	DUMMY INJECTOR	21H	76	M20X1.5
K	90° ELBOW			
L	REPLACEMENT SEAL AND WAHSEK SET			
M	CLAMP PLATE	LENGTH	WIDTH	HOLE DIA.
		64	25	17

KA-7191 Diesel Engine Compression Tester Set

- Measures cylinder pressure on diesel equipped cars and trucks.
- Supplied with one gauge and all necessary adapters.
- Gauge includes release valve and 368mm (14.5") of hose, dial reads from 0 - 1,000 psi and 0 - 70 bar.
- Unique swivel end quick coupler allows the operator to connect the adapters quickly and easily.





KA-7191A Heavy Duty Global Diesel Compression Test Set

Contains compression tester and an assortment of adapters to test a wide variety of vehicles, trucks, heavy-duty equipment deluxe gauge with rubber boot.

- ALLIS CHALMERS, BEDFORD, J.I CASE, JOGN DEERE, FLAT ALLIS, FORD TRACTOR, AUD, BENZ, VW, VOLVO, CUMMINS, NAVISTAR, DETROIT DIESEL, CATERPILLAR.



KA-7191B Diesel Compression Tester

2-1/2" dial, glycering filled gauge with glass lens in stainless steel housing. 4,500 PSI rated nylon jacketed pressure hose assembly. Dual scale -0-1,000 PSI; Metric Scale -0-70 BAR. 13 Piece adapter set (Deere & BMW adapters included)

- AUDI, VOVO, BENZ, PEUGEOT, BMW, CUMMINS, FIAT ALLIS, TOYOTA, ONAN, WAUKESHA, FORD, GM, NAVISTAR...etc



KA-2402 Diesel Engine Compression Tester Set

(FOR CUMMINS ENGINES)

ITEM NO.	ENGINE	TESTING PORT	THREAD
0201	2.9L, 3.9L, 5.9L	FUEL INJECTOR	24.0mm - 1.5
0202	6 BT, 4.02"bore, 5.9 liter	FUEL INJECTOR	24.0mm - 2.0
0203	V-185, V-210, V-225 V-555, VT-255, VT-555	FUEL INJECTOR	
0204	These 5.5" bore engines: NH(855 cubic inches), V-6, V-8, V-12 & 903 V-8 Cylindrical PTB	FUEL INJECTOR	
0205	GAUGE INCLUDES RELEASE VALVE AND 368mm(14.5") OF HOSE, DIAL READS FROM 0-1,000 PSI AND 0-70 BAR.		



KA-2402A Diesel Compression Tester With Adapters

Easy-to-use compression tester is designed specifically for medium-duty engines equipped with glow plugs. Dual reading gauge measures compression to 1000 PSI and 7000 kPa. Gauge has a push-button release valve and quick disconnect fittings on the hose end. Tester comes with all the necessary glow plug and nozzle adapters in a handy storage case.

Tester service these engines:

- Cummins B and C
- Navistar DT466/DT360
- Ford/Navistar 6.9 & 7.3L
- GM 6.2L and 6.5L
- Hino diesel and Mitsubishi Fuso truck engines



KA-2402B Automotive Diesel Compression Test Set

- Tester with handy deflator for releasing air & retesting.
- A 16-1/2" wire reinforced hydraulic hose with a quick coupler on a swivel for ease of connection.
- A 2-1/2" gauge. Records pressures from 0-1000 PSI and 0-70 bar.
- Adapters for All GM, Isuzu, Lincoln Mark VII and Continental, Ford/Navistar, Audi, Mercedes, Peugeot, Toyota, VW, Volvo-Bacharach conversion adapter also included.
- In a red metal box with insert; instructions and specifications included.



KA-7234KA Master Cummins Diesel Fuel Injection Test Kit

Includes the fitting gauge needed to check fuel pressure, fuel volume, and fuel restrictions. Contents:

- Special quick-disconnect banjo fitting (M14 x 1.5 male).
- Two fuel injection quick-coupler adapters.
- Quick disconnect banjo fitting (M12 x 1.5 male).
- Gauge assembly.
- Fuel volume test adapter.
- Diesel fuel inlet restriction test adapter.
- Application: 1988-98 Dodge pickups and vans with 5.9L 12-valve, and 1998 1/2-newer 5.9L 24-valve Cummins Diesel engines.

KA-7239K Diesel Compression Tester Set(For Mack Truck Engines)

Set contains one gauge and a complete adapter system for testing cylinder compression through the injector port on most mack truck engines. Gauge includes release valve and 368mm(14.5") of hose, dial reads from 0 - 1,000psi and 0 - 70bar. Unique swivel end quick coupler allows the operator to connect the adapter quickly and easily.



Application	Engine
Allis chalmers	6000, 7000, 10000, 11000
Bedford	200, 220, 300, 330, 466
Case, J.I.	all models not using pencil nozzle
Deere, John	404, 466, 531, 619
Fiat Allis	8035-02-300, 8035-02-301, 8035-02-302, 8045-02, 8045-03
Ford Tractor	all
International Harvester	D/DT 361, D/DT 429, DV 462, DV/DVT 550 DT/DV/DVT 573, 361, 407
Mack Truck	END 405, 457, 475, 510, 519, 605, 672, 673, 674, 711, 864, ENDT 673, 675, 676, 865, 866
Onan	DSL, MDSL
Waukesha	180DLC, 190D, 195D, 197D
White Farm	66, 77, 88, 99, 166, 177, 188, 199, 550, 660, 770, 880, 950, 1550, 1555, 1600, 1650, 1655, 1750, 1755 & 1800



KA-4365 Oil Pressure Gauge Set

Use on diesel and gasoline engines . Includes standard and metric adaptors for most popular domestic and import cars, trucks, tractors and stationary engines Includes:

- 0-100 PSI (0-700 kPa) Gauge Assembly
- Adaptor (1/8-27 to 1/4-18)
- Adaptor (1/8-27 to 1/-28 BSPT)
- Adaptor (1/8-27 to M12-1.5)
- Street Elbow
- Coupling
- Hose Assembly
- Adaptor (1/8-27 to 3/8-18)
- Adaptor (1/8-27 to 10-1.0)
- Adaptor (1/8-27 to M14-1.5)
- 2" Large Nipple



KA-2877N Diesel Injector puller

Assists removal of stubborn bosch and lucas diesel injectors - saves time and money when injectors are difficult to remove.

- With M8 - M12 - M14 adapters
- L:230mm

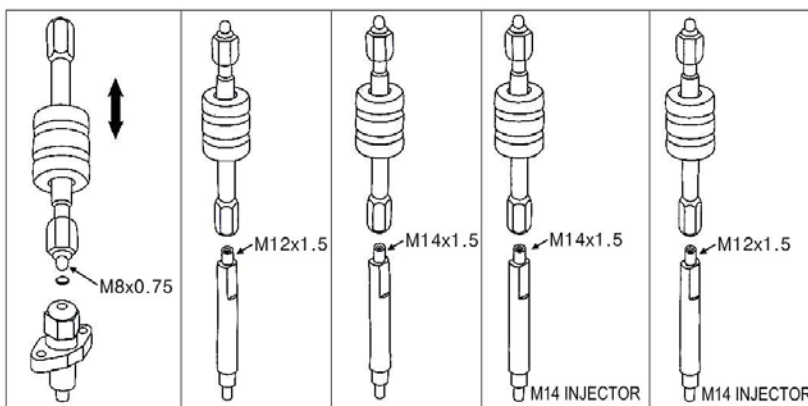



KA-2899K Flow Meter common Rail Set

The purpose of this instrument is to measure rapidly and effectively the amount of fuel that every injector returns to the deposit tank, so that you will know if any injector is damaged.

Features:

- Direct measurement of return flow of the injector
- Measurement of return flow using external flow meter
- Possibility of simultaneous measurement of up to 6 injectors



KA-2899K1 Flow Meter Common Rail Adaptor Set

This kit is design to measure the amount of the fuel that every injector returns to the deposit tank rapidly and effectively.

Therefore, you can detect if the injector is damaged.

Special Feature:

- 24 injector adaptors for BOSCH, SIEMENS, DENSO and DELPHI injector
- Direct measurement of return flow of the injector.
- With use of external flow meter to measure return flow.
- Possibility of simultaneous measurement of up to 6 injectors.
- Blow molded case

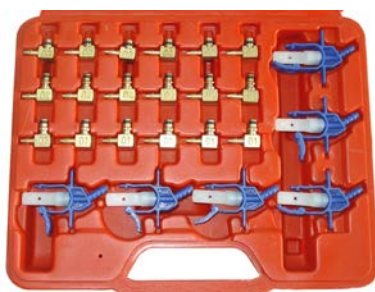

KA-2899K2 24pcs Flow Meter Common Rail Set

- Direct measurement of return flow of the injector
- Measurement of return flow using external flow meter
- Possibility of simultaneous measurement of up to 6 injectors
- Box for transportation and storage is included
- 24pcs injector adaptors: apply for BOSH-01, SIEMENS-02, DENSO-03 and DELPHI injector



**KA-2899K3
Return Fuel Volume Tester for Common Rail Injectors (8V)**

Specification & Application:

1 off measuring unit with 8 off 1000mm rubber hoses.

1set (8 unit) C1 adapters for BOSCH injectors

1set (8 unit) C2 adapters for SIEMENS injectors

1set (8 unit) C3 adapters for DENSO injectors

1set (8 unit) C4 adapters for DEPHI injectors

Packing: Blow Case 10sets/1.2'

“ QUICK REPLACEMENT TYPE “

The purpose of this instrument is to measure rapidly and effectively the amount of fuel that every injector returns to the deposit tank, so that you will know if any injector is damaged.



KA-2899KQC

36pcs For Flow Meter Common Rail (Quick Replacement)

Can used with old type of KA-2899K, KA-2899K1

- Direct measurement of return flow of the injector
- Measurement of return flow using external flow meter
- Possibility of simultaneous measurement of up to 6 injectors
- Box for transportation and storage is included
- Set included 24pc injector adaptors : apply for BOSH-01, SIEMENS-02 , DENSO-03 and DELPHI injector



KA-2898KQC Flow Meter common Rail Set (Quick Replacement)

Features:

- Direct measurement of return flow of the injector
 - Measurement of return flow using external flow meter
 - Possibility of simultaneous measurement of up to 6 injectors
- Box for transportation and storage is included



KA-2898KQC1

Flow Meter Common Rail Adaptor Set (Quick Replacement)

Features:

- Direct measurement of return flow of the injector
- Measurement of return flow using external flow meter
- Possibility of simultaneous measurement of up to 6 injectors
- Box for transportation and storage is included
- Set included 24pc injector adaptors : apply for BOSH . SIEMENS . DENSO and DELPHI injector



KA-2898KQC2

24pcs For Flow Meter Common Rail Set (Quick Replacement)

(Quick Replace Something)

- Direct measurement of return flow of the injector
- Measurement of return flow using external flow meter
- Possibility of simultaneous measurement of up to 6 injectors
- Box for transportation and storage is included
- Set included 24pc injector adaptors : apply for BOSH-01, DENSO-03 and DELPHI injector



KA-7191C Diesel Engine Cylinder Leakage Test Kits

KA-7191C covers most popular cars and vans.
 KA-7191C has additional glow plug adaptors for more coverage and KA-7191C also includes the adaptor set for clamp-type injectors to cover more car, van, truck, bus, agricultural and marine applications.

Glow plug adaptor application:
 Alfa, BMW, Chrysler, Daewoo, Ford, Hyundai, Isuzu, Land Rover, LDV, Mazda, Mercedes Benz, Mitsubishi, Nissan, Opel, PSA, Renault, Saab, Suzuki, Toyota, VAG, Vauxhall, Volvo Diesel Engine.
 Injectors: M20, M22, M24 & Ford Stanadyne injector plus clamp-on injector.



KA-7191D Diesel Engine Compression Tool Kit

KA-7191D includes the additional Clamp-on Injector Adaptor Set, the large 2-1/2", 70 bar (1000psi) gauge with rubber bumper, straight and right angled connect fittings, wide range of glow plug and injector adaptors which enables KA-7191D to cover the majority of car, van, truck, bus, agricultural and marine diesel engines.

Glow plug adaptor application:
 Alfa, BMW, Chrysler, Daewoo, Ford, Hyundai, Isuzu, land Rover, LDV, Mazda, Mercedes Benz, Mitsubishi, Nissan, Opel, PSA, Renault, Saab, Suzuki, Toyota, BAG, Vauxhall, Volvo Diesel Engine.
 Injector: M20, M22, M24 & Ford Stanadyne injector plus clamp-on injector.



VALVE SPRING COMPRESSOR

- FOR LARGE ENGINES & DIESEL ENGINES
- UNIQUE 'DIRECT ACTION' COMPRESSOR LEVER GIVES IMPROVED VISIBILITY & EASE OF USE IN AREAS OF DIFFICULT ACCESS...
- COLLET RELEASE ADAPTERS: RESTRICTED ACCESS ADAPTER, 25MM, 30MM

	JAW OPENING(A)		THROAT(B)
	MIN	MAX	CLEARANCE
KA-5124	35mm	142mm	250mm
KA-5124A	45mm	142mm	250mm

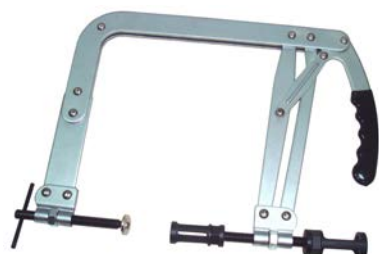

KA-6427 VALVE SPRING COMPRESSOR

- FOR LARGE ENGINES & DIESEL ENGINES
- UNIQUE 'DIRECT ACTION' COMPRESSOR LEVER GIVES IMPROVED VISIBILITY & EASE OF USE IN AREAS OF DIFFICULT ACCESS...
- COLLET RELEASE ADAPTERS: RESTRICTED ACCESS ADAPTER, 25MM, 30MM

	JAW OPENING(A)		THROAT(B)
	MIN	MAX	CLEARANCE
	35mm	200mm	250mm



KA-4310 Ford 7.3L Fuel Cap Tool

- Design allows for easy removal and installation of FORD 7.3L diesel fuel caps and other diesel filter systems using the same configuration.
- Works with fuel caps from 1995 to present.
- Improves ability to remove and install caps where access is a problem.



KA-7018 Heavy-Duty Diesel Engine Nozzle Testing & Cleaning Set

FOR ALL DIESEL ENGINE CARS & TRUCKS

For Testing injection nozzle opening pressure, leakage spray pattern, Atomization & Chatter Characteristic & Cleaner.



Capacity: SAFE WORKING PRESSURE

- Max.: 9000 PSI (640 KG/CM²)
- Adapters: M-12 x P1.5, M-14 x P1.5, M-16 x P1.5
- Weight: 8 kg
- Pressure Gauge: 70mm, Pump: 11mm, Stroke: 20mm
- Discharge Amount: 2.0cc

- Simple & Easy to operating by hand
- Follow New International Standard
- Clean the Nozzle with **3M** Cleaning Solution for Diesel Nozzle. (Please fill the Cleaning Solution in the white pot)

Pressure unit conversion table

	psi	bar	kg/cm ²
1PSI	1.0	0.069	0.07
1BAR	14.5	1.0	1.02
1kg/cm ²	14.2	0.98	1.0

1bar=100kPa

WARNING

1. Before operating, please fill the pump with approx. 6cc diesel fuel to avoid idling.
2. To avoid injury by high pressure spraying while operating, do not stand in front of the nozzle, do not place hands in front of the nozzle, do not expose any body parts in front of the nozzle, please do not operate when any person is standing in front of the nozzle.
3. Please wear safety goggles or slippery-proof footwear.
4. Please do not operate near fire.

KA-7018A Diesel Engine Nozzle Testing & Cleaning Set

- The liquid tank is provided with a filter.
- Supplied with M14xM14 and M14xM12 pipes.
- Weight: 2 kg
- 3.5" dial gauge reading 0-600 bar also reading 0-8700 lbs/sq.Inch.

WARNING

1. Keep away from any heat places
2. We recommend using special fluids to operate this device properly, such as Shell oil S.9365. or 1P Fanum Fluid Cd.



KA-7782 Oil and Diesel Oil filter Wrench

- 14 sides
- A: 74mm, B: 68mm



KA-7783 Oil and Diesel Oil filter Wrench

- 8 sides
- A: 74mm, B: 35 mm



KA-7784 Oil and Diesel Oil filter Wrench

- 10 sides
- A: 92mm, B: 43 mm



KA-7785 Oil and Diesel Oil filter Wrench

- 15 sides
- A: 105mm, B: 67 mm



KA-3138 UNIVERSAL TWIN / 4 CAM LOCK (GAS & DIESEL ENGINES)

- It is designed to lock twin camshafts to timing marks during timing belt replacement
- Fit onto sprockets and extends to lock into sprocket teeth
- Adjustable arms to fit various diameters and tooth pitch
- Also suitable for locking between cam and diesel inj. Pump sprockets on man opporation.



KA-5242 Universal Twin/4 Cam Lock (Gas & Diesel Engines)

- It's designed to lock twin camshafts to timing marks during timing belt replacement. Fit onto sprockets and extends to lock in to sprocket teeth. Adjustable arms.
- To fit various diameters and tooth pitch. Also suitable for locking between cam and diesel inj. Pump sprockets one man opporation.



KA-7779 Diesel Injection Pump Wrench

- 13mm 12PT 90 Degree Crank.
- Made for fastening screws at the injection pump, when replacing the toothed belt or adjusting the injection starts.
- Application: 1.6 4 cylinder Diesel engine Audi 80, VW Golf, Jetta Caddy, Passat Santana



KA-9001A Viscous Fan Hub Spanner

- For removal of thermo, Viscous fan hubs. Cranked for easy access.
- Size: 32mm
- Application: BMW 316i, 520i, 525i, 530i, 535i, 730i, 735i
FORD CAPRI, SIERRA GRANADA 2.0 & 2.8
FORD TRANSIT 2.0 1986-90.(with viscous fan)
LCX 2.0, LCT 2.0, 2.5 DIESEL 1980-90, LCX 2.5D & LCY 2.5D



KA-3633 Special Wrench for Turbo

The Special Wrench For Turbo
Special wrench for screwing on the turbo-charger in diesel engines of VW / AUDI; new model, short type, from now on very convenient assembling and disassembling for screw underneath the turbo-charger.

- For:VW / AUDI
- Drive: 3/8" □
- Size : 12 mm x 12PT



KA-5171 Diesel Injector Nozzle Socket

- 1/2" DR. socket can use for SIEMENS & BOSCH
 - Size: 25, 27, 29, 30mm
- Suitable for Peugeot and Citroen with 2.0 engines (110/135HP) HDI engine.



KA-2054 3pcs Diesel Injector Puller Set

- This special designed diesel injector puller set is ideally for the need to remove stubborn diesel injector. No need to remove cam cover and the use of slide hammer. Fitted mainly to Mercedes C-class, E-class, Sprinter Vehicles and Chrysler Grand Cherokee 27crd(00-)



KA-2056 Diesel Injector Nozzle Extractor Set

Suitable for PSA 2,0 (110, 135 HP) HDI engines e.g. Peugeot, Citroën etc. (engine code DW 10)

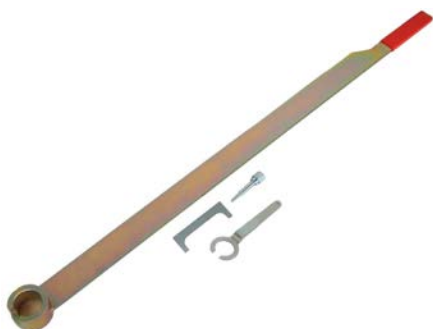

KA-8374 Diesel Engine Setting/Locking Tool Set

- VW GROUP 2.5TDI common rail diesel engines (Belt) in **VOLKSWAGEN** LT Crafter **BJJ, BJK, BJL and BJM engines**

- Contents:
 - Crankshaft pulley holding tool
 - Crankshaft locking pin
 - Camshaft setting plate

Tensioner adjuster



KA-3100DAD Diesel and Gasoline Timing Light with Tach/Dwell/Volt Tester

- Works on all 12V and 24V diesel and gasoline engines.
- High impact ABS housing
- Detachable heavy duty inductive pick-up clamps. Leads and diesel sensor for easy operation and replacement.
- Bright xenon flash tube provides concentrated light for easy visibility of timing mark.



KA-2200DTA Diesel Advance Timing Light with

- Works on all 24 volt diesel engines.
- High impact ABS housing
- Detachable heavy duty inductive pick-up clamps. Leads and diesel sensor for easy operation and replacement.
- Bright xenon flash tube provides concentrated light for easy visibility of timing mark
- Adjustable advance knob with scale reading in direct degrees.



KA-001DB Diesel Converter Box

- Fits for all timing lights

KA-8340

VW 3-IN-1 Bosch VE Fuel Injection Pump Adapter Timing Tool

Tools are used for the accurate setting of the Bosch diesel fuel injection pump timing. The holder screws into the back of the injection pump, giving a dial indicator reading necessary for setting the correct pump timing. This set comes complete with the correct tools for the job.



Contents:

- Bosch Diesel Injection Pump Timing Indicator Tools
- Dial Indicator and Holder

- Metric Dial Indicator, plusholder plus extension pins(2) making the timing easy to set, as the timing has a range from 0.83mm to 1.15mm. For use on VW and Audi diesels.
 - Indicator Holder Set - suitable for timing Bosch VE injection pumps. Includes M8, M10 and M12 adapters. To be used in conjunction with Dial gauge.

Applicable : Bosch VE fuel pump, Diesel pumps. Indicator Holder for both size shanks. Also works with 1981-1986 Volvo 6 cyl 2.4L diesels, 1989-1994 Dodge 6 cyl 5.9L diesels.

KA-8340A VW Bosch VE Fuel Injection Pump Adapter Timing Tool

Tools are used for the accurate setting of the Bosch diesel fuel injection pump timing. The holder screws into the back of the injection pump, giving a dial indicator reading necessary for setting the correct pump timing. This set comes complete with the correct tools for the job.



Contents:

- Bosch Diesel Injection Pump Timing Indicator Tools
- This set has a dial gauge with an 8mm shank.
- Dial Indicator and Holder

- Metric Dial Indicator, plusholder plus extension pins(2) making the timing easy to set, as the timing has a range from 0.83mm to 1.15mm. For use on VW and Audi diesels.
 - Indicator Holder Set - suitable for timing Bosch VE injection pumps. Includes M8, M10 and M12 adapters. To be used in conjunction with Dial gauge.

Applicable : Bosch VE fuel pump, Diesel pumps. Indicator Holder for both size shanks. Also works with 1981-1986 Volvo 6 cyl 2.4L diesels, 1989-1994 Dodge 6 cyl 5.9L diesels.

KA-6358 2-In-1 Diesel Fuel Pump Timing tool

For Bosch VE type pumps (including KIKI and Nippon Denso) with 8-12 threaded pump threads.



Contents:

- 1x30mm TUNUBG KIIK (F)
- 1x30mm PUMP TOOL EXTENSION
- 1x8x12mm ADAPTOR
- 1x42mm PUSH ROD
- AX82MM PUSH ROD



KA-6797 13pc Diesel & Petrol Engine Timing Kit



KA-6798 8pc Ford Diesel Engine Injection Timing Tool

Applications: 1600cc & 1800cc diesel engines fitted to Ford Fiesta, Escort, Orion, P100, Sierra and Mondeo models.
 Also suitable for 2500cc DI engines on 1985 and later Ford Transit Vans and Galaxy 1900cc TD vehicles.



KA-5137 Engine Turning Tool

- For use on cummins 855 cubic inch diesel engines.
- Easily turns engine over without damage to accessory drive pulley
- Aids in adjusting valve or timing injectors.
- 24" long for extra leverage.



KA-5134 12PCS ENGINE TIMING SET – LAND ROVER

- NEW EDC MANUAL TRANSMISSION TIMING PIN.
- 200 TDI 300 TDI & 2.5 DIESEL ENGINES
- COMBINED CRANKSHAFT DAMPER PULLER AND FUEL PUMP GEAR LOCKING TOOL



KA-8274 Renault Timing Kit (DCI Engine)

- Set of camshaft and crankshaft locking pins for Renault diesel and petrol engines.
- Suitable for locking engine during cam belt replacement or during associated engine maintenance.
- Application: Renault Diesel; Modus, Clio, R19, Megane, Scenic, Laguna, Espace, Kapace, Kangoo, Extra, Express, Rapid, Trafic 1.5dCi/1.9D/1.9TD1.9dTi, Engine Codes: K9K, F8Q, F9Q-Petrol; Clio, R19, Laguna 1.8/2.0, Engine Codes: F3P F3R, Tool Codes: MOT1489, MOT1430, MOT1054



KA-8238 Diesel Engine Locking / Setting Kit + Pump Duse

- Setting and locking kit for a range of VAG vehicles with Pumpe Duse TDI PD (1.9) and V6 engines.
- Contents: Injection pump locking pin, locking tensioner tool and crankshaft locking tool.



KA-8253 Engine Timing Tools

Applicable:

- VW-AUDI 2.5 TDI V6 and AUDI A8 3.3 TDI V8 ENGINE.
- AUDI V6 PETROL AND V6 / V8 DIESEL ENGINE.



KA-8267 Engine Timing Tool Set

contains:

- This comprehensive set of tools enables the correct timing positions to be achieved on both camshaft and crankshaft whilst replacing the timing belt or chain on both petrol and diesel engines.
- Includes a special wrench for controlled turning of the exhaust camshaft sprocket when removing and installing the VANOS unit
- Includes primary Timing Chain Pre-Load tool for tensioning the timing chain on M50 engines
M22 Threaded for M42/M60 Engines.
M26 Threaded for M50/M52 Engines



KA-8256 Engine Timing Tool Set For VW & Audi

- This kit of twelve tools is required for petrol and diesel engine service including timing belt replacement on recent models and also older 1.9D models from 1976.
- Models: Audi: A4, A6, A8, A11 year(97-04)
VW: Passat: (98-04)
Engines Codes: AFB, AKE, AKN AYM, BAU, BCZ, BDG, BDH, BFC



KA-8256A Engine Timing Tool for VW & AUDI W/4 GROOVES and ALU FINISH

- This new kit of twelve tools is required for petrol and diesel engine service including timing belt replacement on recent models and also older 1.9D models from 1976.
- Models: AUDI: A4, A6, A8 , A11 yoad (97-04)
VW: PASSAT: (98-04)
Engines codes: AFB, AKE, AKNAYM, BAU, BCZ, BDG, BDH, BFC.



KA-8256B Engine Timing Tool – VW & AUDI

- This new kit of twelve tools is required for petrol and diesel engine service including timing belt replacement on recent modles and also older 1.9D models from 1976.
- Models: AUDI: A4, A6, A8 , A11 yoad (97-04)
VW: PASSAT: (98-04)
Engines codes: AFB, AKE, AKNAYM, BAU, BCZ, BDG, BDH, BFC.



KA-8263 Engine Timing Tools – VW & AUDI W/4 GROOVES and ALU FINISH

- This kit of twelve tools is required for petrol and diesel engine service including timing belt replacement on recent models and also older 1.9D models from 1976.
- Models: Audi: A4, A6, A8, A11 year(97-04)
VW: Passat: (98-04)
Egnines codes: AFB, AKE, AKN AYM, BAU, BCZ, BDG, BDH, BFC





KA-8213 Engine Timing Tools – VW & AUDI

- For Petrol And Diesel Engine Service
- Application: Timing Belt Replacement for Recent Models , Older 1.9d Models From 1976.
- For Following MODELS:
AUDI: A4, A6, A8, All Road (97-04)
VW:PASSAT: (98-04)
- For ENGINES CODES: AFB, AKE, AKN, AYM, BAU, BCZ, BDG, BDH, BFC.

KA-8229 Diesel Engine Setting / Locking Kit

- Anodized finish for corrosion protection.
- Instructions for use are printed inside this card.

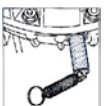
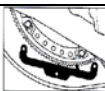



	For vehicles without this type of sump pan, use the flywheel TDC setting tool. Secure the tool to the cell housing with the marker point bent in towards the flywheel ting gear. Align the TDC mark on the flywheel with pointer.
	Any other use of these tools than that described in the section above is considered as misuse.
	On vehicles from 1998on, the injection pump locking pin is required as part of the procedure. With the TDC set up, pass the locking pin through the hole in the timing pump gear and locate it.

KA-8229A Diesel Engine Setting / Locking Kit – OPEL, Vauxhall

- This tool set allows the precise location of the crankshaft in the TDC-Position against the fly-wheel.



	<p>TDC-Locking Tool for Crankshaft</p> <ul style="list-style-type: none"> ● Application: Astra 1,7 D up to '97 ● Adjusting Tool for the TDC-Marking on the flywheel.
	<p>Locking Pin for Flywheel/Crankshaft</p> <ul style="list-style-type: none"> ● Application: Astra 1,7 D from '98 ● Pin fir locking the crankshaft in the TDC-Position.
	<p>Locking Tool for Flywheels</p> <ul style="list-style-type: none"> ● Application: Opel/Vauxhall Diesel-Engines(Isuzu) ● With 1,5 and 1,7 and for Opel/Vauxhall Fuel-Engines(OHC) from 1,2 to 2,0

KA-8214 KA-8214A Diesel Fuel Pump Timing Set

It is made for Resetting The Timing Postion On Diesel Engines
 Application for following fuel pumps:
 Bosch Ep/VeRotory, Kikki, Nippon Denso, Cav Roto diesel in Alfa Romeo, Audi, Bmw, Daihatsu, Fiat, Ford, Isuzu, Iveco,Lancia, Land Rover, Mazda, Mitsubishi, Nissan, Renault, Rover And Volkswagen.



KA-8214A

Includes:
 --locking pin Ø15.5 for VW/Audi
 --fixing gauge for VW/Audi/Ford etc
 --guide bolt set for front beam

KA-8215 Diesel 1.7 OPEL & ISUZU

- Applicable MODELS: OPEL ENGINES: ASTRA, CAVALIES, VECTRA-A (87-00), ISUZU,N OVA, CORSA/COMBO, ASTRA, CAVALIER, VECTRA, FRONTERA, MONTEREY, MIDI,
- BRAVA (88-04)
- ENGINES OPEL:16DA, 17D, 17DR, X17DTL ISUZU:4EC1, 4EE1, 4JB1,4XJ1, 4JA1,4JG 2, 4FC1, 4FD1, 4FG1, Z17DT,Y17DT/DTL.



KA-8220 Engine Timing Tools Set – VGA

- This Kit if designed for Petrol and Diesel Engine.
- This Kit is for following services:
 Timing Belt Replacement for recent models or older 1.9D Models 1976 onward.





KA-8219 Engine Timing Tool Set – CITROEN & PEUGEOT

- This Sets make the engine timing job correctly while replacing the timing belt.
- For most recent models with Petrol or Diesel Engine.



KA-8258 Engine Timing Tool Set- Citroen & Peugeot

This comprehensive set tools enables the correct engine timing to be made when replacing the timing belt. Suitable for use on the most recent cars with either HPI(petrol) or HDI(diesel) engines.

Citroen: AX, BX, ZX, XM, VISA, SAXO, XSARA, XANTIA Synergie/Evasion, Berlingo, Jumpy, C15, C25, Picasso, C5

Peugeot: 106, 205, 305, 307, 309, 405, 406, 605, 607, Expert, Partner, Boxer



KA-8283 Engine Timing Tool Set – CITROEN & PEUGEOT

- This comprehensive set tools enables the correct engine timing to be made when replacing the timing belt.
- Suitable for use on the most recent cars with either HPI(PETROL) or HDI (DIESEL) engine.



KA-8243 Diesel Engines 1.5/1.9/2.2/2.5 DCI

- CLIO, MEGANE, SCENIC, LAGUNA, ESPACE, KANGOO, TRAFIC & MASTER(99-04).
- ENGINE: 1.5, 1.9, 2.2&2.5DCI.
- CODES: K9K, G9T, G9U.



KA-8216 Diesel 1.3 CDTI- OPEL

Applications:

VAUXHALL / OPEL 1.3 CDTI COMMON RAIL.

VAUXHALL / OPEL CORSA, COMBO Z13DT ENGINE.



KA-8218 Diesel 2.0 & 2.4 TDDI-TDCI (chain)

- MODELS:MONDEO & TRANSIT (01-04)
- ENGINES 2.0 & 2.4 DURATORQ 16V.
- CODES: FMBA/B, D5BA, ABFA, D3FA, D2FA, D4FA, F4FA.



KA-2472K

43pcs Diesel & Petrol Setting / Locking & Timing Kit – French Cars

The most complete kit of timing and setting tools for French engine applications available. Suitable for new Di and twin cam engines and includes unique Multi-Lock timing device which can be used to lock camshaft to fuel injection pump in sync. Includes tools for camshaft, injection pump, crank 'lock', tensioner adjustment, twin cam setting and RAM/EPIC injection timing adjustment. Supplied with full applications listing. Includes carry case.

Applications:

Setting/Locking – Citroen, Peugeot, Renault Diesel and Petrol Engines. Also engines fitted in Fiat/veco, Vauxhall, Rover, Volvo, LDV, Chrysler, Mitsubishi, FSO and Tata.

Fuel Injection Pump Timing / Adjustment – Renault RAM timing System and PSA 'EPIC' injection pumps.



KA-8234 Diesel Engine Setting / Locking Tool Kit

Models: ASTRA, ZAFIRA, VECTRA & SIGNUM(04-)



KA-8270 Engine Timing Tool Set For Professional Engine Repair

Feature:

Petrol Engines:

FIAT Brava, bravo, Barchetta, Cargo, Coupe, Marea, Palio Weekend, Punto, Multipla, Stilo, Idea Doblo Twin Can Genines 1.2 1.4 1.6 1.8 16V

Diesel Engines:

FIAT Barva, Bravo, Marea / Weekend, Palio, Punto. Multipla, Doblo, Ulysse, Ducato, Stili JTD Diese Engines 1.9D / TD 1.9JTD 2.4TD/JTD



KA-8276 Engine Timing Tool Set For-BMW

This comprehensive set of tools enables the correct timing positions to be achieved on both camshaft and crankshaft whilst replacing the timing belt or chain on both petrol and diesel engines.

- Includes a special wrench for controlled turning of the exhaust camshaft sprocket when removing and installing the VANOS unit
- Includes primary Timing Chain Pre-Load tool for tensioning the timing chain on M50 engines
 - M22 Threaded for M42/M60 Engines
 - M26 Threaded for M50/M52 Engines
- This set enables the correct timing to be made when servicing BMW M47 2.0 16 engines.

E46	318D	302D	330D
E39	520D	525D	530D
E38	730D		



KA-8277 Engine Timing Locking Tool Set FORD/MAZDE

- Designed for pulling off the camshaft timing belt wheel and locking or positioning the engine output shafts such as the camshaft and the crankshaft.
- Required for changing the timing belt or for engine repair.

Applicable for FORD 1.8 D/TD/TDCI diesel and 1.25-2.0 16V Zetec petrol engine e.g FORD Fiesta, Fscore/Oruon, Focus, Puma, Sierra, Modeo, Cougar, Couier/Kombi, P100 and Mazde 121



KA-8278 Engine Timing Tool Set – Opel / Vauxhall

- Changing the timing belt suitable for identical engines in e.g: Saab., Renault...etc
- Locking the camshaft and crankshaft
- Diesel engine 1.3CDTi, 1.6v, 1.9CDTi, 2.0DTi, 2.2DTi

Application for Agila, Combo-C, Corsa, Frontera, Omega, Sintra, Tigra, Vectra, Zaira,
 Petrol engine 1.0 12v / 1.2
 16V(since 97) 1.4/1.6/1.8/2.0/2.2
 16V(since 95)



KA-8261 Engine Timing Tensioner Kit

For most petrol and diesel engines
A comprehensive range of tension lever and wrenches required for changing the cam belt on most popular petrol and diesel engines including: Alfa Romeo, Fiat, Citroen, Peugeot, Renault, Volkswagen



KA-8317 Diesel Injection Pump Puller For BMW

This tool is specifically designed for holding the sprocket/chain in place when disassembling the VP44 injection pump and high pressure pump.

- Common rail fitted to BMW engines:
318D/compact(E46), 320D/TD compact(46), 330D(E46), 525D(E39), 525D(E60/E61), 530D(E39), 530D(E60/E61), 535D(E60/E61), 730D(E38), X53.0D(E53)



KA-8285



KA-3656 Diesel Injection Pump Puller for Land Rover

This tool is specifically designed for holding the sprocket/chain in place when disassembling the VP44 injection pump and high pressure pump.

- Common rail fitted to Land Rover engines:
Land Rover / Freelander (TD4) / Rover / 75 (M47)



KA-8286 Puller for Injection Pump Tools Kit for BMW

- Applicable for BMW 4 cylinder diesel engine(M41), 6 cylinder diesel engine- 2,5(M51) also for Opel/Vauxhall Omega 2,5 TD.
- To loosen the injection pump pulley form the shaft when dismantling the injection pump.



KA-8299 Injection Pump Adjustment Tool

Suitable for Renault, Mitsubishi, Opel/Vauxhall and Volvo 1.9 direct-injection diesel engines (F8Q and F9Q) with adjustable injection pump wheel. e.g. Renault Megane/Scenic, Kangoo; Mitsubishi Carisma; Opel Arena and Volvo S40/V40.

The injection pump to the camshaft (start of delivery) can be adjusted with the injection nozzle adjustment tool in conjunction with the KL-0129-1 A set of tools and the required locking tools.

Content:

- Special socket wrench insert 27 mm hex for the hub fixing screw
- Adjusting wrench with 3 pins (for turning and adjusting the hub)
- Adaptor for Bosch injection pumps (M10x1 to M8x1)



KA-8314 Engine Timing Tool Set for Professional Engine Repair

- For BMW diesel engines M41, M51, M47TU, M47TU/T2, M57/ TU / T2: 2.0l / 3.0l year 1998-2008
- Installation and removal of the camshaft / hydraulic chain tensioner
- Checking and adjustment of camshaft timing.
- Easily accessible operating instructions including cross references to original part numbers
- Spare parts optionally available.
- Clear arrangement of tools in high-quality plastic case with soft foam insert

E36:	318tds / 318tds Compact BJ. 94-00 / 325td /tds BJ. 91-99	E38/E65/E66:	730d
E34/E39:	525td/tds BJ. 91-03	E83:	X3 , 2.01d / 3.01d
E38:	725tds BJ. 91-03 M47 / M47TU / T2 / M57TU / T2	E53/E70:	X5 , 3.01d
E87:	118d / 120d	E90/E91:	316i , 316ti , 318ci , 318ti , 320i
E46:	318d / 318td Compact / 320td Compact / 320d / 330d		
E39:	520d / 525d / 530d	Land Rover:	
E60/E61:	525d / 530d / 535d	Land Rover:	2.5DT BJ. 1994-2002
E63:	635d	Land Rover:	3.0TD6 BJ. 2002-2006
		Freelander:	2.0TD4 BJ. 2002-2006



KA-8324 Diesel Engine Camshaft Locking Tools For VGA/FORD/VOLVO

- The diesel timing kit is a set of essential tools for setting and locking the camshaft and crankshaft when changing the timing belt on Audi Seat Volvo and Volkswagen diesel engines.
- The kit also forms a part of the engine timing & locking and the comprehensive diesel engine and fuel pump timing & locking kit

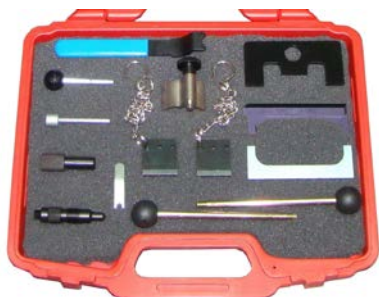

KA-8326 Timing Devices For Audi/Seat/ Skoda and Volkswagen Engine

Applicable : Audi/Seat/ Skoda/ Volkswagen, 75HP (cylinders)-90HP-100HP-110HP-115HP-130HP-150HP Engine Timing Tool Kit

- This tool kit is used to maintain petrol and diesel engines and replace the timing belt on many models.

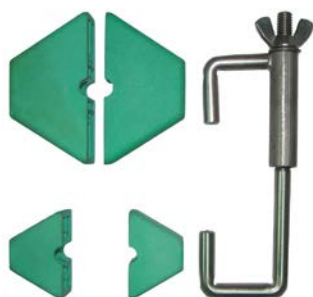

KA-8329 Universal Sprocket Locking Device For Twin Cam & Quad Cam Engines

- Universally adjustable for toothed pulleys spaced between approximately 5mm to 85mm apart
- For engines with twin camshafts (CITROEN FIAT FORD HONDA RENAULT ROVER SAAB SUBARU TOYOTA VOLVO) and for diesel engines to lock the camshaft and injection pump (VW-Audi Ford Seat Skoda)
- By inserting the locking tool in the drive pulleys it is during repairs or changing the timing belt.

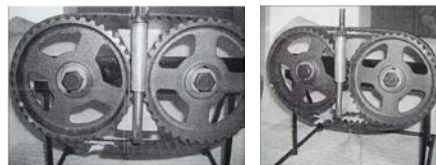

KA-8327 Diesel Engines Timing Tool Set For Fiat 1.7D/1.7TD 1.9D 1.9TD

Applicable: Fiat Punto 1.7D/TD Tipo 1.9D/Ducato 1.9D/Tempra 1.9D Tipo 1.9TD/Ducato 1.9TD/Tempra 1.9TD diesel engines with an adjustable camshaft timing belt pulley.

Item No.	Vehicle	Year	Component	Engine Codes	Applicable
KA-8327-17 Diesel Engine Locking Tool Set For Fiat Punto 1.7D/TD	Punto 1.7D Punto 1.7TD	1996-1997	Camshaft Locking Tool-A	176 B3.000 176 A3.000 176 A5.000	Fiat Punto 1.7D/TD diesel engines with an adjustable camshaft timing belt pulley.
KA-8327-19D Diesel Engine Locking Tool Set For Fiat Tipo 1.9D/Ducato 1.9D/Tempra 1.9D	Tipo 1.9D Tempra 1.9D Ducato 1.9D	1987-1998 1987-1998	Camshaft Locking Tool-B	149 B1.000 160 A6.000 160 A7.000 160 D1.000 230 A2.000 230 A3.000 230 A4.000 280 A1.000	Fiat 1.9D/Ducato 1.9D/Tempra 1.9D diesel engines with an adjustable camshaft timing belt pulley.
KA-8327-19TD Diesel Engine Locking Tool Set For Fiat Tipo 1.9TD/Ducato 1.9TD/Tempra 1.9TD	Tipo 1.9TD Tempra 1.9TD		Camshaft Locking Tool-A Camshaft Locking Tool-B	149 B1.000 160 A6.000 160 D1.000 230 A2.000 230 A3.000 230 A4.000 160 A7.000 280 A1.000	Fiat 1.9TD/Ducato 1.9TD/Tempra 1.9TD diesel engines with an adjustable camshaft timing belt pulley.

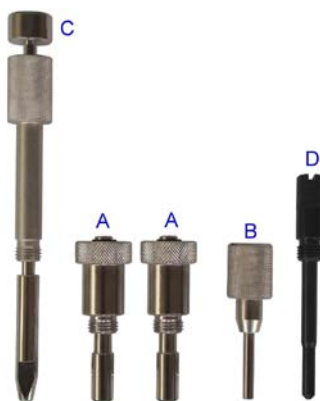

KA-8332 Diesel Engine Timing Tool Set For Fiat 2.3 JTD

This kit includes the latest crankshaft timing pin required from 2006-2008. The 2.3 JTD twin camshaft common rail diesel engine is belt driven between crankshaft and inlet camshaft but utilizes a chain to connect both camshaft. The high pressure fuel pump does not require timing. Follow all the manufacturers' specified procedures in preparation to remove the worn or damaged timing belt.

Part	Description
A	Camshaft Timing Pins (2)
B	Camshaft Timing Pins (2005)
C	Camshaft Sprocket Alignment Pin
D	Camshaft Timing Pins (2006)

Manufacturer	Model	Engine Size	Year	Engine Code
Fiat	Ducato	2.3JTD Multijet 120	2002-06	F1 AE0481D, F1AE0481N
Fiat	Ducato	2.3JTD Multijet 120	2006-08	F1 AE0481D, F1AE0482N
Fiat	Ducato	3.0JTD Multijet 160	2006	F1AE0481D



KA-8344 Diesel Engine Timing Locking Tool Kit

This kit can use for PSA2.5, FLAT 2.8D, Iveco, Renault and Vauxhall. Include 2pcs setting pin, 1pc flywheel locking pin and 1pc tensioner retaining tool.

- Also for Citroen/Peugeot, Fiat and Iveco models Traffic(80-00), Master(80-07), Mascot(99-07).
- Fiat, Psa, Renault models Daily(91-05), Turbo daily(94-00).
- Relay/Jumper(01-02), Boxer(00-06).

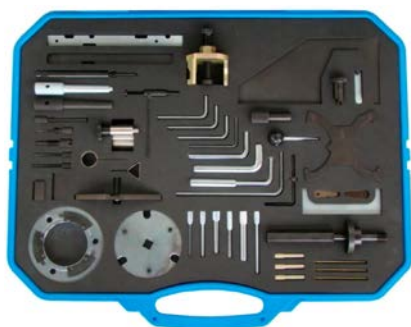

KA-8362 Engine Timing Tools for FORD

Applicable: for Ford 1.25L 1.4L 1.6L 1.8L 2.0L 2.4L Cmax / Cougar / Couier / Duratec-SCI / Fieata / Focus / Fscore / Fusion / Kombi / Mondeo / Puma / Sierra / Tourneo / Transit petrol engine and diesel engine



KA-8364 Timing Belt Tool Set For VW TDI

- Used for locking the camshaft, crankshaft and diesel pump while setting the timing belt.
- Applicable for 1999-2008 VW TDI and pumped use engines.
- Includes new-style cam lock bar.
 - Both 2 pin spanner wrenches
 - Both styles of crankshaft stops



KA-8375 Diesel Engine Setting/Locking Tool Set

- BMW N47/N47S 2.0d Diesel engine in:
 - 1 series: 118d (E81/E87), 120d (E81/E82/E87), 123d (E81/E82/E87)
 - 3 series: 318d (E90/E91), 320d (E90/E91/E92)
 - 5 series: 520d (E60/E61)
 - X3 2.0d: (E83)
- Contents:
 - Flywheel locking pin
 - Camshaft setting plate
 - Crankshaft turingtool

- Identify injector "blow-by" exists (The leaking of combustion gases from the cylinder through the injector seat, the "blow-by" causes starting symptoms and poor running, excessive smoke, tar build-up, loss and noise of compression).
- Re-face the diesel injector seat in order for the new or reconditioned injector to be fitted correctly.
- Clean and re-cutting of injector seat.
- Avoid a high risk of "blow-by" occurring cause of the build up of carbon deposits and the effects of corrosion.
- Application for all modern common rail diesel engines.
- Don't use with air tools



KA-3636A 5pcs Diesel Injector Seat Cutter Set

Material: CRMO

Kit contents:

- 15mm Flat Reamer for Universal injector.
- 17mm Flat Reamer for Delphi/Bosch injectors (BMW/PSA/Renault/Ford).
- 19mm Flat Reamer for Bosch injectors (Mercedes CRD).
- 19mm Angled Reamer for Fiat/Iveco.
- Pilot post x 1pc



KA-3636AE 6pcs Diesel Injector Seat Cutter Set

Material: CRMO

Kit contents:

- 15mm Flat Reamer for Universal injector.
- 17mm Flat Reamer for Delphi/Bosch injectors (BMW/PSA/Renault/Ford).
- 17mm Angled Reamer for Mercedes Benz CDI
- 19mm Flat Reamer for Bosch injectors (Mercedes CRD).
- 19mm Angled Reamer for Fiat/Iveco.
- Pilot post x 1pc



KA-3636B 6pcs Diesel Injector Seat Cutter Set

Material: CRMO

Kit contents:

- 15mm Flat Reamer for Universal injector.
- 17mm Flat Reamer for Delphi/Bosch injectors (BMW/PSA/Renault/Ford).
- 19mm Flat Reamer for Bosch injectors (Mercedes CRD).
- 19mm Angled Reamer for Fiat/Iveco.
- T handle x 1pc
- Pilot post x 1pc



KA-3636C EVA Tray



KA-3636E 7pcs Diesel Injector Seat Cutter Set

Material: CRMO

Kit contents:

- 15mm Flat Reamer for Universal injector.
- 17mm Flat Reamer for Delphi/Bosch injectors (BMW/PSA/Renault/Ford).
- 17mm Angled Reamer for Mercedes Benz CDI
- 19mm Flat Reamer for Bosch injectors (Mercedes CRD).
- 19mm Angled Reamer for Fiat/Iveco.
- T handle x 1pc
- Pilot post x 1pc



KA-3636D 8pcs Diesel Injector Seat Cutter Set

- Used for cleaning place under injection washer after replacing injector.
- It is necessary to clean place under and above washer for perfect fit new or replaced diesel injector.





KA-3636G 8pcs Diesel Injector Seat Cutter Set

*Carbon Residue tends to accumulate on the injector seat and injector nozzle
Regular diesel injector seat cutter seat only cleans and cut the injector seat, but
KA-3636G not only clean the seat but also the nozzles*

- A complete kit to service seat & injector nozzle
- Clean the injector nozzles
- Clean and re-cut the injector seat
- Re-face the diesel injector seat to fit the new or reconditioned injector correctly.
- Application for all modern common rail diesel engines.
- Don't use with air tools
- Material: CRMO



Kit contents:

- 15mm Flat Reamer for Universal injector.
- 17mm Flat Reamer for Delphi/Bosch injectors (BMW/PSA/Renault/Ford).
- 17mm Angled Reamer for Mercedes Benz CDI
- 19mm Flat Reamer for Bosch injectors (Mercedes CRD).
- 21mm Angled Reamer for Fiat/Iveco.
- Injector Cleaner (58-60 degree)
- T handle x 1pc
- Pilot post x 1pc



KA-3642 Copper Washer Removal Tool For Diesel Injector

- Size: inner hole 7
- Length: 230mm
- Collet type easy to holding the copper washer.



KA-8377 Diesel Injector Remover



- This specialist kit is designed primarily for removing seized diesel injectors from VAG TDI engines
- The set includes a 0.5kg slide hammer with threaded adaptors in direct, offset and hook profiles.
- Model: VAG-TDI



KA-4027 4pc Diesel Injector Removal Set-Delphi & Bosch

Specifically designed for removing Delphi/Bosch diesel injectors using a Slide Hammer with 5/8" UNF thread.
 Adaptors can also be used with an air tool to loosen the injectors by vibration.
 Set of 3 adaptors plus a special tool for removing the internal part of Bosch injectors.



KA-8374 Diesel Engine Setting/Locking Tool Set

- VW GROUP 2.5TDI common rail diesel engines (Belt) in
VOLKSWAGEN LT Crafter
BJJ, BJK, BJL and BJM engines
- Contents:
 Crankshaft pulley holding tool
 Crankshaft locking pin
 Camshaft setting plate

Tensioner adjuster



KA-4028 Puller for Sealing Ring

For use on sealing rings with internal diameter 4 - 16 mm, e.g. injector nozzle sealing rings on Mercedes CDI engines.
 The puller extracts the sealing rings correctly, for example from between the injector nozzle and the cylinder head.
 To pull out the sealing ring, screw the taper point of the tool into it, then remove with the impact-type puller.



KA-3639 Injector Puller Set

Mercedes CDI
 This six piece puller set has been especially designed for removing stubborn injectors on Mercedes Benz vehicles fitted with CDI engines.
 Packed in a blow moulded case.

Injector Extractor

- With this tool, when removing seized or stuck Common Rail injectors, no more need to disassemble the cylinder head.
- Applicable for MERCEDES-BENZ CDI engines 611, 612, 613, etc.
- Especially for the limited spaces due to the cylinder head cover



KA-3968

- Contents:**
- 1 Impact Extractor
 - 1 Injector Claw
 - 1 External Adapter
 - 1 Slide Hammer



KA-3970

- Contents:**
- 1 Impact Extractor
 - 1 Injector Claw
 - 1 External Adapter

Injector Puller For Mercedes-Benz (slide hammer style)

- For removing adapted tight common rail injectors without having to disassemble cylinder head.
- Use for Mercedes-Benz CD engines 611.612.613...etc.
- Injection puller with impact hammer, injection nozzles that do not fit very tightly can be pulled out without needing to take them apart or remove the cylinder block.

KA-3969 4PCS



KA-5167B 6PCS



KA-5167C 7PCS

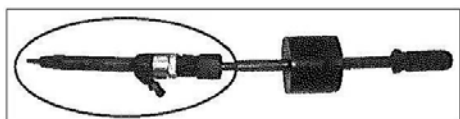

This high quality tooling is designed for the removal of stuck and seized injectors.

KA-5167A 9pcs Common Rail Injectors Extractor Set

Feature:

- With slide hammer for DB CDI-engines & Mercedes CDI engines OM 611, 612, 613 etc.
- For removing stuck and the seized common-rail injectors without dismount the cylinder head.
- The sturdy construction will enable the swift removal of even the most severely seized in injector.

Specification:

- Material: S45C steel
- Total Length: 350mmL
- Contents: Slide Hammer (1.75kgs)
Adaptor M17 x 1.0
Adaptor M27 x 1.0 for Bosch injector nozzle.
Adaptor: Puller w/M12 x 1.75



KA-3664 VW. AUDI Common Rail Diesel Injector (TDI)

- Special two jaws design to fix the injector and pull out with slide hammer
- Applicable: VW, AUDI (TDI) engine



KA-3665 VW. AUDI Injectors Remover Set (FSI)

- Use "U" sleeve or two jaws hook to fix the injector and then pull out with slide hammer
- Applicable: VW, AUDI (FSI) engine



KA-3677 Solution For BMW Common Rail Injectors

- Complete set for removing **BMW CR** Injectors without dismantling the cylinder head.
- Equipped with a blower adapter to clean the injector seats.
- Bosch injectors: common rail injectors mounted on BMW
- Application Engines: BMW Common Rail : M47TU, M57, M57TU
- Content:
 - KA-3677-01 M17-M16 screw with num
 - KA-3677-02 Hexagonal wrench to remove the solenoids
 - KA-3677-03 Main extractor's body
 - KA-3677-04 2 pcs x 140mm support foot
 - KA-3677-05 2 pcs x 115mm support foot
 - KA-3677-01 Ch.29 socket with 1/2 connection to remove the electronic group



KA-3678

Removing and Cleaning BMW Injectors Common Rail Diesel

- Complete set for removing **BMW CR** Injectors without dismantling the cylinder head.
- Equipped with a blower adapter to clean the injector seats.
- Bosch injectors: common rail injectors mounted on BMW
- Application Engines: BMW Common Rail : M47TU, M57, M57TU , M87, M87TU

KA-4296 Glow Plug Removal Set

Diesel Engine requires GLOW PLUG for combustion process in engine cylinder. The heating element in glow plug heat up and drive the cylinders gradually. But the heating elements are very delicate, and require special tool for removing the glow plug. KA-4296 is the best tool set for successful removal of glow plug.

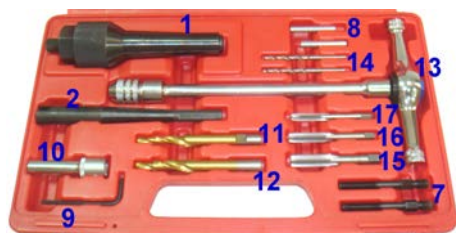

Specification

Parts No.		Parts No.	
1	Hex 12mm spindle, Hex 30mm nut, cone center tool	11	7 x 5.5
2	Drill installer	12	9 x 5.5
7	1/4" -28 UNF, Hex 9mm -2pcs	13	T-handle
8	Ø6 x 3.5 x 40L -2pcs	14	Ø3.5 drill -2pcs
9	Alley key	15	M10 x P10
10	9.7mm square socket	16	M8 x 1.0
		17	1/4" - 28UNF



KA-7845 Diesel Engine Low Pressure Diagnostic Kit

- KA-7845 is designed specifically to inspect the low pressure or return fuel side of diesel engines.
- Two manometers with different scales (-1~5 & -1~15 bar) offer accurate pressure loss inspection results.
- Ten fuel line adapters fits wide range of diesel engines.
- Translucent tube on adapters makes the observation of impurities and air bubbles in the fuel system easily.
- 2 meter long hoses allow the connections in the confined area in engine compartment.
- Quick and efficient to find leaks.
- Application: the supply of fuel from the tank.



KA-4033 Glow Plug Tool Set

- For Mercedes CDI engines
 - Suitable for Mercedes CDI engines OM 611, 612 and 613.
 - The glow plug tool set KA-4033 enables the correct removal of burnt and/or stuck due to corrosion or torn off glow plugs as well as the repair of the glow plug retaining thread.
 - The cylinder head does not have to be removed.
- (Note: Screwing the compressed air adapter into the injector nozzle bore and injecting compressed air into the combustion chamber prevents dirt and metal particles from entering the combustion chamber)*

Advantage:

- Large time saving and cost saving
- Clean working methods.
- The tool is easy to operate.



KA-3676 Truck Injectors Solution

- Injector puller solution SSANGYONG & MERCEDES
- Special Injector puller solution for new generation trucks
- Application rang: SSANGYONG, MERCEDES, trucks with injector-Pump systems or with traditional truck injectors (Volvo, scania, Mercedes, man, Renault, iveco, etc...)
- Content:
 - KA-3676-01 socket for Delphi injectors & Trucks
 - KA-3676-02 Injector "hook"
 - KA-3676-03 Extension handle
 - KA-3676-04 Upper handle
 - KA-3676-05 Body-tamper
 - KA-3676-06 Cardanic joint
 - KA-3676-07 M18 x 1.5 nut

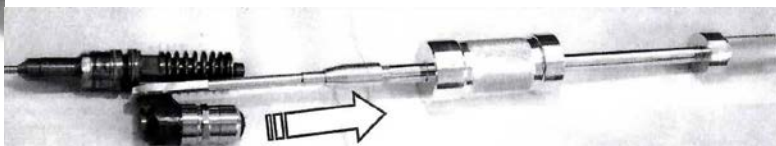



KA-7845 Diesel Engine Low Pressure Diagnostic Kit

- KA-7845 is designed specifically to inspect the low pressure or return fuel side of diesel engines.
- Two manometers with different scales (-1~5 & -1~15 bar) offer accurate pressure loss inspection results.
- Ten fuel line adapters fits wide range of diesel engines.
- Translucent tube on adapters makes the observation of impurities and air bubbles in the fuel system easily.
- 2 meter long hoses allow the connections in the confined area in engine compartment.
- Quick and efficient to find leaks.
- Application: the supply of fuel from the tank.