



### KA-4521 FUSO Flywheel Holder (Manual)

Use for holding flywheel to prevent from rotating.

**Applicable:**

FUSO EURO 5 lift cars/IVECO engine. (MANUAL)  
FUSO NO.: MH063967  
IVECO NO.: 99360306



### KA-4522 FUSO & IVECO Crankshaft Rear Oil Seal Removal Tool

- Use for installing IVECO F1C ENGINE / FUSO LIFT CARS(EURO 5) Crankshaft
- Rear seal installation.

**Applicable:**

Models: DAILY  
IVECO OEM no.ref.: 99346259  
FUSO NO.: MH063963



### KA-4523 Diesel Oil Filter Wrench For FUSO 401

- Use for removing the plastic case when replacing the filter.
- Size: 1/2"Dr. x  $\Phi$ 96.5 x 12PT

**Applicable:** FUSO 401/ Daewoo Bus.



### KA-4524 FUSO Crankshaft Front Oil Seal Installation Tool

- Use for installing crankshaft front oil seal.

**Applicable:**

FUSO EURO 5 lift cars / IVECO engine.  
FUSO NO.: MH063962  
IVECO NO.: 99346258



### KA-4525 FUSO Crankshaft Front Oil Seal Removal Tool

- Use for removing front crankshaft oil seal.

**Applicable:**

FUSO EURO 5 lift cars/ IVECO engine.  
FUSO NO.: MH063989  
IVECO NO.: 99340059



**KA-4526 FUSO Diesel Injector Removal Tool**

- Use for removing the injector connector from diesel engine.

**Applicable:**  
 FUSO EURO 5 lift cars/ IVECO engine.  
 FUSO NO.: MH064377  
 IVECO NO.: 99342156



**KA-4527 FUSO Fan Clutch Holder (2 point)**

- Use for holding the clutch to remove the fan axial nut.

**Applicable:** FUSO EURO 5 engine  
**FM number:** MH064219.



**KA-2197 Super Thin Back Probes With Angles**

- Probes are provided in straight, 45° and 90° can access to connectors in limited spaced.
- Super thin probes access to connector back easily between the insulation and weather seal, creating contact on the metal part without damage the insulation.
- 6 colors help identify different lines for testing.
- Rear side of female 2mm to connect probes from digital multimeter (DMM) without needing additional adapters.



- A. Straight: 0.7mm probe overall length 202±2mm
- B. 45°: 0.7mm probe overall length 197±2mm
- C. 90°: 0.7mm probe overall length 183±2mm
- D. Multimeter probe connector

**Instruction:**

1. Refer to the wiring diagram on the automotive manufacturer's manual.
2. Locate the connector and identify the line to be tested.  
 If multiple lines will be tested, then use back probes with different colors.
3. Insert the test probe into the rear side of the connector (Fig. 1) and feel a slight resistance to make sure the probe is in contact with the metal part.
4. Connect digital multimeter (DMM) to the test probe.
5. Remove the multimeter after a reading is made.

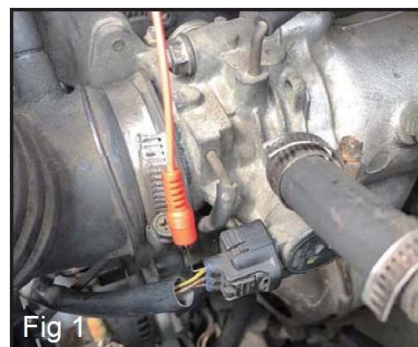

**KA-2199 Universal Thread Restoring File**

- The universal thread restoring file is designed to renew all 60° machine screw.
- Fractional, metric, NPT and NPS pipe thread sizes of any diameter.
- It will restore right or left hand threads.
- Thread angle: 60°
- Length X size: 9" x 7/8" x 1/8"



**KA-1267D 90° Axle Hose Clamp Pliers**

- Material: steel & alloy
- For spring clamp range: 3/4" ~ 2-3/4"
- Length: 185mm
- Weight: 470g
- Patented



The patented ratcheting feature provides user with infinite locking positions.

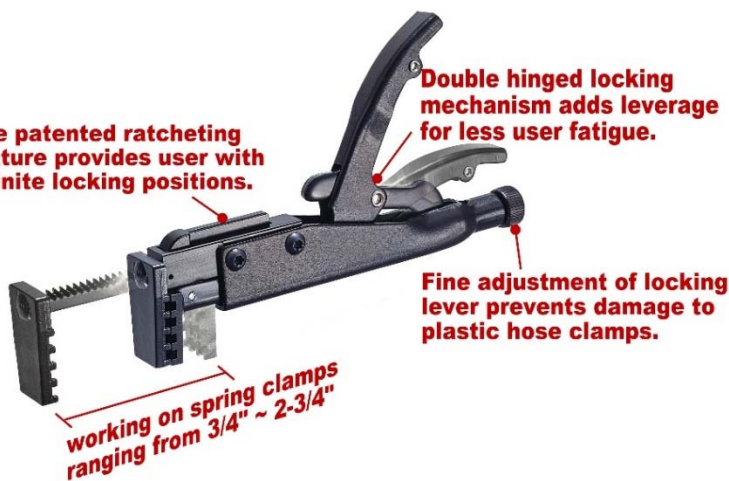

**KA-2198 Drive Shaft Joint Inserter**

- It is guide of the C-Ring tool.
- Compress the circlip that is spreading, and fix the fixed joint.
- C ring can be reliably held. It can be assuredly assembled.
- Since it is a screw type, you can easily compress the circlip evenly.
- All length: 150mm
- Max open range: 50mm

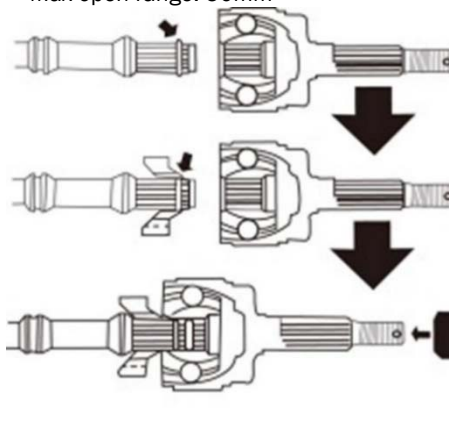



**KA-8064 Engine Timing Tool Kit For VAG 1.6/2.0 TDI**

- An 8 piece kit consisting of the components required to lock the crankshaft, Cam pulley and fuel pump pulley in their timed positions to allow the removal and replacement of the camshaft timing belt
- Application: 1.6 / 2.0 TDi diesel engine.



**KA-8065 Combination Timing Tool Set For BMW N47**

- This set for installing and removing camshaft & variable camshaft timing unit, also for aligning the balance shaft and crankshaft timing position.
- BM number: 115320, 116480, 118760, 118740, 113340, 114320, 118750, 118790.

**KA-2201 Metric Socket / Wrench Insert Set (No-Marring)**

- Ideal for classic and high quality vehicles.
- Sizes 12mm reduced to 8mm, 14 reduced to 10mm, 16mm reduced to 12mm, 17 reduced to 13mm, 19mm reduced to 15mm, 22mm reduced to 17mm.
- Prevents damage to Chrome and anodised bolts (Non marking).

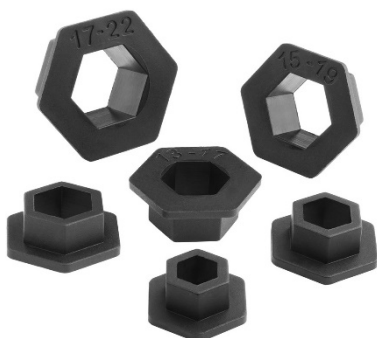

Fastener	Socket	Torque
8 mm	12 mm	9 Nm
10 mm	14 mm	17 Nm
12 mm	16 mm	27 Nm
13 mm	17 mm	45 Nm
15 mm	19 mm	50 Nm
17 mm	22 mm	79 Nm



**KA-4133 Fuel Return Line Tool For VAG TDI – CR**

- Designed for professional removal / installation of the fuel return line push – fit connector (round type) at the injectors.
- Suitable for VW, Audi, Skoda, Seat 2.0, 2.7 and 3.0 TDI common rail diesel engine.



Models	
<b>VW</b>	Eos, Golf V - VI, Jetta, Passat, Passat CC, Scirocco, Tiguan, Transporter T5, Phaeton
<b>Audi</b>	A3, A4, A5, A6, A7, Q5
<b>Skoda</b>	Yeti
<b>Seat</b>	Exeo
Engine codes	
BMK, BPP, CAAA, CAAB, CAAC, CAAD, CAAE, CAGA, CAGB, CAGC, CBAA, CBAB, CBAC, CBDA, CBDB, CBDC, CDUD	





**KA-2202 Airbag Removal Tool for Land Rover**

- To release the driver airbag module from steering wheel.
- Suitable for land rover discovery 3-4, Freelander 2 and Range Rover Sport.

**Instruction:**

1. Place the hook into the small slot on the side of the steering wheel rear casing.
2. Insert the tool and then engage the retaining spring.
3. Pull on the tool while pushing gently on the airbag (to reduce the pressure on the retaining spring).



**KA-4134 Crankshaft Pulley Assembly Tool Set (VAG)**

- Used for dismounting and mounting the crankshaft pulley on 4-cyl. 1.8L / 2.0L 4V TFSI direct injection petrol engine (third generation EA888 – timing chain).
- Tools for securing crankshaft pulley, keep everything in time while performing a chain service.



**KA-4135 Hybrid Belt Tensioner Tool For Hyundai /Kia**

- The tool must be used to compress the stiffer hydraulic tensioner as part of the Hybrid Starter Generator (HSG) belt removal steps.
- Suitable for: Hyundai sonata / Ioniq  
Kia Optima / Niro



**Contour Gauge**







- **Instant template**  
Works well in copying the shape of irregular items, replicate the shape of moldings or match cut outs, providing you with accurate reads.
- **Flexible shaping measure ruler**  
This contour profile gauge can be applied to copy or track the shape of irregular objects, with ruler on the top, you can quickly figure out the size of them, instant template for marking precise tile cut.

**KT-2908 5"**  
**KT-2908A 10"**

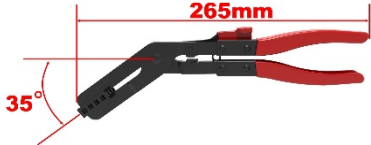

**Universal Hose Clamp Plier**

- Special jaws designed for most kinds of hose clamp.
- Finger tip "position lock" to keep hose clamp spread open.

Item No.	Capacity	Angle Jaw	Length
<p><b>KA-2357</b></p> 	0 ~ 65mm	--	
<p><b>KA-2357N35</b></p> 		35° angle	
<p><b>KA-2357L</b> - Extended</p> 	0 ~ 50mm	--	
<p><b>KA-2357LN35</b> - Extended</p> 		35° angle	



**KA-4104**  
**Valve Spring Compressor 4.0, 4.6 with Valve Spring Compressor Spacer**

Ford valve spring compressor for 4.0 SOHC and some 4.6 V8's –Ford p/n T95T-6565-A OTC and Rotunda 303-581. Primarily used on Ford 4.0L SOHC V6's.





**KA-4106 Clamping Washer Tool for VAG / Ford**

- For quick and safe removal / fitting of clamping washers which are used on underbody heat shields ...etc.
- Applications for: Audi, Seat, Ford, Volkswagen, Skoda.
- The clamping washers are also found on many other vehicle marques.
- 1/4" dr. with quick chuck end for use with 1/4" dr. wrenches, drivers or cordless drills.
- Can compatible with connect clamping discs for VAG.

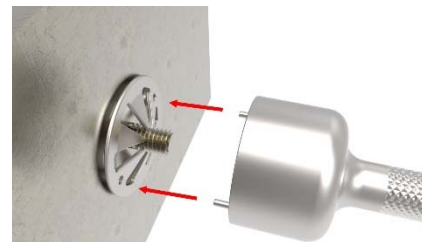

**KA-4103 Harmonic Balancer Remover**

- This balancer remover is suitable for a variety of engines that are fitted with 3 & 6 spoke balancers.

- Applicable:  
GM V8 engines: 5.3Litre, 5.7LS1, 6.0LS2, 6.2LS3, 7.0Litre.  
Ford: Coyote 5.0 supercharge.  
Chrysler / Dodge / Jeep: 3.5Litre, 3.7Litre V6, 4.7Litre, 5.7Litre, 6.1Litre.



**KA-5258 Front Wheel Nut Socket (four holes) For Suzuki Jimny**

- Special designed to remove the four holes front wheel nut.
- Applicable: SUZUKI (JIMNY) 1.3.



**KA-4514A Shock Absorber Tool Kit (15pcs)**

- Contents:**  
 7 x Go Through deep sockets: 16, 17, 18, 19, 21, 22, 24mm  
 4 x 1/2" Dr. Hex bits: 5, 6, 7, 8mm  
 1 x 1/2" Dr. sliding T-Bar  
 2 x 1/2" Dr. slot bit sockets 5x8mm, 6x8mm  
 1 x 21mm Hex. Go through ratchet



**KA-4101 Ball Joint Adapter Set for Lexus / Toyota**

- This set is used in conjunction with the C-frame to remove and install ball joints on select Lexus and Toyota vehicles.
- Set contains adapter for use on:  
Lexus - 2003~2009 GX470  
Toyota - 2003~2017 4 Runner, 2007~2014 FJ Cruiser.





### KA-4107 Head Bolt Remover for Ford 6.0L

Use with 3/4" drive tools to transmit high torque needed to loosen and tighten head bolts. Allows access to rear head bolts by eliminating the need to remove the cab from the chassis, prevents damage to rear heat shield and eliminates the need to remove the evaporator housing.



### KA-6875 EGT Sensor Socket Set

- Designed to remove most exhaust temperature sensors.
- Straight and offset in single Hex (6PT) x 3/8" Dr.
- Size: 13, 14, 17mm
- Suits to use on cars, light commercial and HGVs.

Due to heat cycles and the corrosive environment in the modern diesel exhaust system. The EGT sensors become very difficult to remove without damaging them. This set of sockets is designed to drive all 6 sides of the hex equally to reduce the chance of damage.



### KA-6078F Manual ATF Refill With 20 Adapters

**Nylon material . Lightweight . Durable . Economy**

- Manual type pressure tank to refill ATF on automatic transmissions without a dipstick.
- Includes 20 adapters for most common vehicles.
- Tank with 6 liter / quarts capacity, suitable for most transmissions - Audi, Cadillac, Ford, GMC, Infiniti, Mercedes, Nissan, Toyota, Volkswagen, and Volvo.
- Specially designed tank base for feet to step on to stabilize the tank while pumping.
- Adapters in nylon 6-6 material provides lightweight but also durable features.



### KA-6000B Oil Extractor Set

- Manual type vacuum creator for extracting engine oil (and ATF, coolant...etc)
- Tank capacity 6 liter / 1.5 gallon
- Tank base for feet to step on to stabilize the tank while pumping
- Transparent hose makes it easier for mechanics to check extracted engine oil quality
- Conical pour spout for spill-free waste oil discharge



### KA-3771S Injector Shaft Cleaning Set

To clean the injector shaft and seat as well as the injector surface.



Description	KA-3771S
Wire Brushes Ø18, 19, 21, 24, 26	Each 1 pc
Cleaning brushes (9 x 100 x 300mm)	2 pcs
Flexible bit holder	1 pc
Adaptor with brush holder	1 pc
Mounting bar	1 pc
1/4 Hex cleaning brushes	2 pcs
Sealing plugs	8 pcs
Cleaning brush sleeve	1 pc
Sand paper discs	1 bag



### KA-4108 Ford Fuel Line Disconnect Tool - 5/16 x 3/8

- Ford Fuel Line Disconnect Tool - 5/16" x 3/8"
- Both Ends Required Due to Limited Clearance Between Fuel Line Connector End and Fuel Rail
- Services Transit 20L, 35 GTDI, 62L Boss Engines



### KA-4109 Transmission Oil Cooler Line Disconnect For Ford

- Two sizes of 3/8" and 1/2" are designed to disconnect transmission cooler lines.
- Simply push the line toward the connector, then engage tool and pull line from connector.
- Use 3/8" size for 2003 and later Ford V8 Explorer, 2004 and later Ford F150 and Cadillac vehicles
- Use 1/2" size for Ford F250, F350 and F450 Super-Duty trucks



### KA-4111 10 Point Socket Set- 8mm & 10mm

- For removal and installation of the driver side & front passenger side seat tracks.
- Both sizes needed for this application.
- For 2009 & up Honda Odyssey and Pilot seat tracks.
- 1/4" square drive.
- Material: CR-MO

### KA-4112 Steering Wheel Spacer Sleeve Puller Kit (Puller and Drive-In Mandrel)



- Clamping range: 27 - 30 mm
- Drive-in Mandrel for Spacer Sleeves:
- The drive-in mandrel made of brass allows the spacer sleeve to be pushed into the steering column without risk of damage.
- Suitable for vehicle models as from 1988 onwards such as VW Golf (II and III), Jetta, Vento, Polo, Passat, etc.

When replacing steering column switches, it is necessary to firstly remove the steering wheel and then to extract the spacer sleeve from the cone.

The special design of the puller ensures that its collet chuck precisely encompasses the spacer sleeve which enables quick and smooth extraction of the spacer sleeve.



### KA-4113 VAG Special Tool Pipe Wrench For Damper Cartridge

- Mounting the damper cartridge Front for Audi 100, Audi 200 and A6 C4 models.
- For opening and closing the cap nut on the strut.
- Drive 1/2 "square drive.



### KA-4114 Chrysler Transmission Dipstick

- Use on 6F24 automatic transmissions found on Late model 2012 and up Dodge Dart, Fiat 500, Jeep Cherokee, Compass & Patriot.
- Black finish with reverse printing on scale for easier reading.
- Knurled handle, Tapered end.



### KA-4115 Through-Handle Specialty Pry Bar

- Unique shapes for prying in restricted locations
- Heat-treated and tempered alloy steel for superior strength
- Great for body shop applications and front end alignments
- Material: CR-MO



### KA-4116 Glow Plug Aperture Cleaner

- This tool offers an adjustable cleaning solution for M10 glow plug apertures
- For cleaning M10 glow plug apertures when replacing glow plugs
- Particularly useful when the original glow plugs have been removed
- Size: M10x1.0 and M10x1.25



**KA-4117 Disc Brake Pad Thickness Gauge**

- Fast and efficient measure for brake disc thickness.
- Performing the measure without wheel removal.
- Patented Taiwan, European



**KA-2166-2226A 3 Pcs Centering Sleeve Set**

- For fast disassembly and assembly of truck tyres.
- No damage to thread as well as exact centering of the wheel to hub nut by tapered sleeves.
- Application: DAF, FORD, MAN, MERCEDES-BENZ, RENAULT, VOLVO.
- High precision due to precise threading.

**Specification:**

- Drive: 1/2".
- Length: 115 mm.
- Internal thread: M22 x 1.5.
- For rim hole: Ø26mm.
- Black Oxide Finished.



**KA-7192T 500C.C Brake Bleeder**



**KA-4123 Camber adjustment tool for BMW rear axles**

- Ideally suited for adjusting the camber on the rear axle
- The rear wishbones can be moved with this therefore setting the camber
- Application range: BMW 3 series, (E36, E46)



**Truck Brake Cage Bolt Socket**

**Quickly Unlocks Truck Air Brakes.**

- Use in 1/2" DR. Can be used with impact wrenches.
- Extra deep 1-1/16" socket loosens the cage bolt to unlock air brakes on trucks.
- Can remove the air brake booster for replacement.

**KA-4100-1116** 1/2" Dr. x 1-1/16"

**KA-4100-1516** 1/2" Dr. x 15/16"

**KA-4100-34** 1/2" Dr. x 3/4"



**Adjustable Ratcheting Wrench**

- Combine adjustable and ratcheting functions.
- Forged with high-end stainless molybdenum vanadium steel.
- Easy to operate
- Time Saver



Item No.	Size
KT-C203A-0911	9mm, 10mm, 11mm, 11/32", 3/8", 13/32", 7/16"
KT-C203A-1214	12mm, 13mm, 14mm, 15/32", 1/2", 17/32", 9/16"
KT-C203A-1517	15mm, 16mm, 17mm, 19/32", 5/8", 21/32", 11/16"
KT-C203A-1820	18mm, 19mm, 20mm, 23/32", 3/4", 25/32"
KT-C203A	KT-C203A-0911 + KT-C203A-1214 + KT-C203A-1517 + KT-C203A-1820



Push the jaw to open the calmp onto the nut.



Drive the clamp to tight and release the nut.



**KA-3800 2 In 1 Multi Wire Stripper & Crimper Tool**

- Easy One-Hand Selector Switch.
- One end features a professional grade stripper for AWG sizes 10, 12, 14, 16, 18 and 20 Gauge wire.
- Flip the handles around and you have a full range crimper for 22-18, 16-10 size terminals.
- Three position safety lock: open to switch, lock to hold on position, closed to prevent operation.

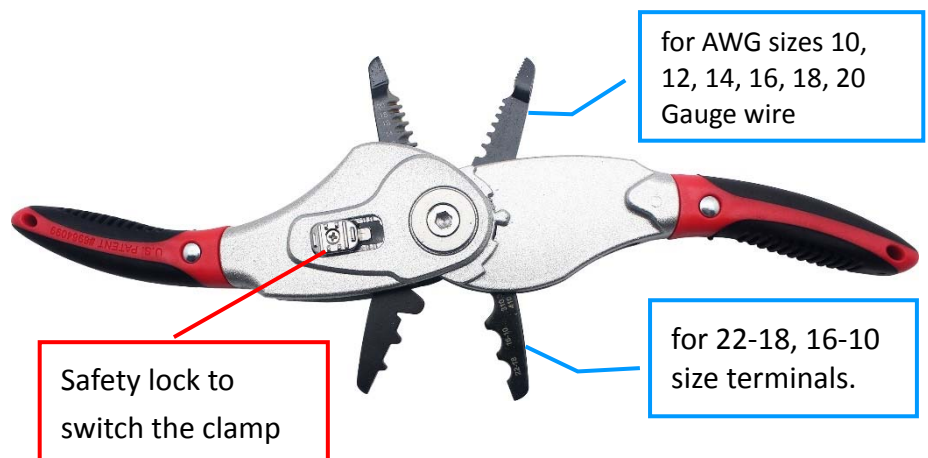

### KA-5462 8" Internal/External Snap Ring Pliers

Operates both internal & external rings.  
 Unique jaw design to easily remove for straight and 90° angle tips.  
 Alloy steel and PVC grip with storage for tips.



**Specification:**  
 Overall length: 7"  
 Width: 5"  
 Thickness: 23mm

**Content:**  
 1 set - straight tips for 1.2mm & 1.8mm  
 2 set - 90° tips for 1.2mm & 1.8mm  
 1 pc - hex key

Screw the nut to  
 Quick & Easy Change  
 Tips Without Tools

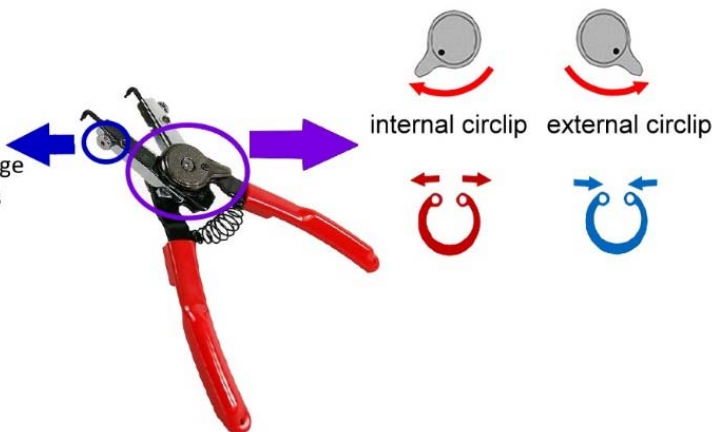

### KA-5463 16" Heavy Duty Snap Ring Pliers With Reversible Action

Switch internal / external  
 Replaceable tips, adjustable stop  
 External ring size: 89 - 165mm  
 Internal ring size: 78 - 159mm  
 Tip size, straight tips 2.8 & 3.2mm  
 90° tips 3.2mm  
 1pc hex key for change head function  
 Material: carbon steels



#### Assembling Process

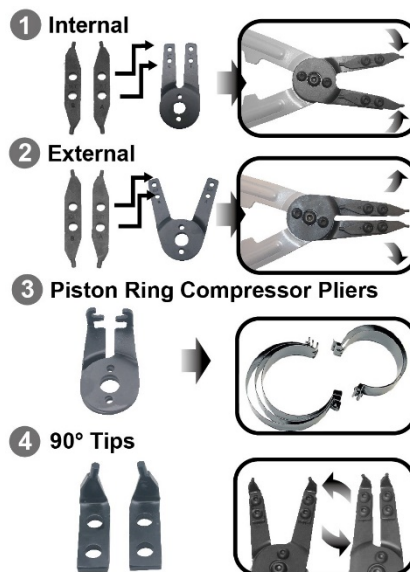
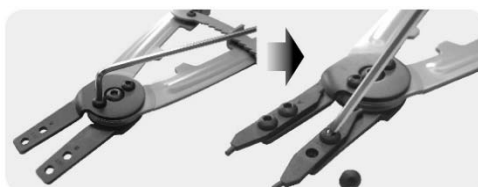

### KA-5461 8" & 16" Circlip Plier Tool Set

#### Contents:

16" circlip plier	
Internal head	2pcs
2 in 1 internal tips	2pcs
External head	2pcs
2 in 1 external tips	2pcs
90° tips	2pcs
Piston ring compressor plier head (73 to 117mm / 2-7/8" to 4-5/8")	2pcs
Hex key	1pc
screw	6pcs
8" circlip plier	
Straight tips	2pcs
90° tips	4pcs
Hex key	1pc





**Multi-Grip Self Adjusting Pliers**

- Special design of jaws auto-adjust to any size with one-handed operation.
- Layered steel construction for added strength.
- Combo straight and V-type jaws for hex, square and round objects.
- Non-slip shaped cushioned grips for comfort.

**KA-3801K** 7" & 10"

**KA-3801S** 7"

**KA-3801M** 10"



**KA-3799 12" Oil Filter Pliers**

- Two stage action that automatically adjusts to the size of the filter, then tightens.
- Layered steel construction for added strength.
- Features serrated jaws to maximize grip & non-slip handles for added control.
- Capacity: 60-120mm diameter.



**A/C Compressor Clutch Holding Tool (Ford-Europe)**

- Hold the A/C clutch hub with the special tool.
- Remove the hub bolt and A/C clutch disc.
- 3/8" Dr.

<b>KA-4140A (2.0L Panther L4 diesel engine)</b>	
Transit	2013~
Transit Custom	2012~
<b>KA-4140B (DV6 engine)</b>	
C-MAX	2010~, 2015~
Fiesta	2017~
Focus	2010~, 2014~, 2018~
Ka+	2016~
Kuga	2012~
Transit/Tourneo Connect	2013~
Transit/Tourneo Courier	2013~
<b>KA-4140C</b>	
B-MAX	2012~
C-MAX	2010~, 2015~
Fiesta	2008~, 2012~
Focus	2010~
<b>KA-4140D</b>	
C-MAX	2010~, 2015~
Ecosport	2012~
Edge	2015~
Fiesta	2018~, 2012~, 2017~
Focus	2010~, 2014~, 2018~
Galaxy	2015~
Kuga	2012~
Mondeo	2014~
S-Max	2015~
Transit	2013~
Transit Custom	2013~
Transit/Tourneo Connect	2013~
Transit/Tourneo Courier	2013~

**KA-4140A**  
 ■ OEM Ref. 412-157

**KA-4140B**  
 ■ OEM Ref. 412-154

**KA-4140C**  
 ■ OEM Ref. 412-103

**KA-4140D**  
 ■ OEM Ref. 412-134

48"

36"

24"

12"

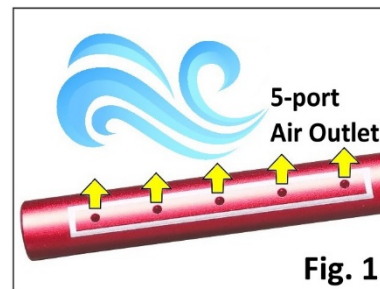
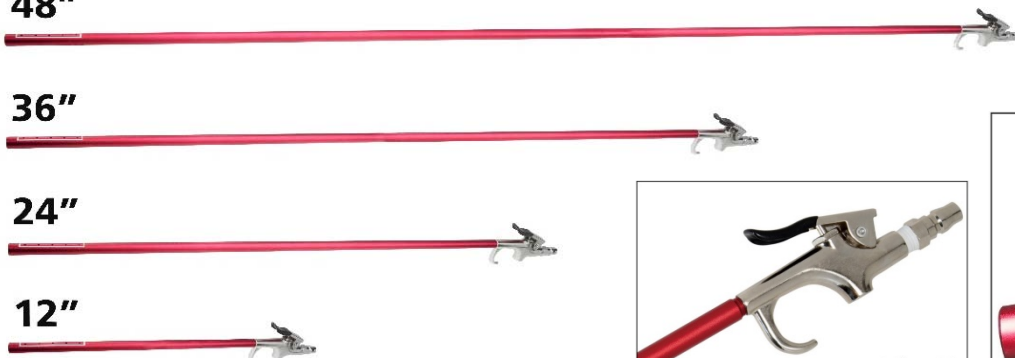

**Tube-Type Cleaner With Air**

- Tube type cleaner with compressed air to clean hard-to-access areas, such as filters and radiator.
- 90° angle and 5-port air outlet to increase accessibility and maximize air pressure and volume (Fig. 1).
- Ergonomic handle design enables users to control the air direction easily and work with the tool comfortably (Fig. 2).

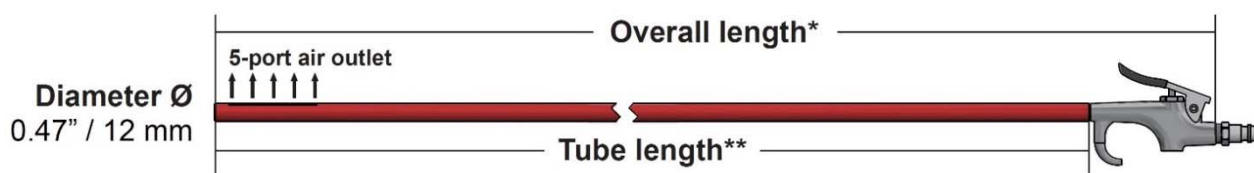

Specification:		Item No.	KA-4123-12	KA-4123-24	KA-4123-36	KA-4123-48
Tube material	Aluminum	Tube length	12"	24"	36"	48"
Working Pressure	90 psi / 6.2 bar	Tube length	304mm	609.6mm	914.4mm	1219.2mm
Max. pressure	170 psi / 11.7 bar	Overall length	15"	27"	39"	51.1"
Avg. air consumption	5 CFM / 140 LPM	Overall length	383mm	688mm	993mm	1298mm
Inlet threads	1/4"	Tolerance	±0.08" / ±2mm			

**Instructions:**

1. Connect shop air to the cleaner tool.
2. Insert the tube to the car part or area to be cleaned (Fig 3).
3. Use one hand to hold the tube for stabilization during operation (Fig 4).
4. Use the other hand to hold the handle.
5. Press the trigger to introduce air into the tool to clean.



**KA-5464 Crankshaft Socket for Subaru**

- Used to align crank to T.D.C. while working with timing chain. Also works on older 3 or 6 cylinder Dohc engines.
- Application:
  - 2013-2015 SUBARU-BRZ
  - 2012-2015 SUBARU-FORESTER
  - 2012-2015 SUBARU-IMPREZA
  - 2015-2015 SUBARU-IMPREZA WRX
  - 2013-2015 SUBARU-LEGACY
  - 2013-2015 SUBARU-OUTBACK
  - 2006 SUBARU-OUTBACK,(6-CYL.)
  - 2006 SUBARU-TRIBECA B9
  - 2013-2015 SUBARU-XV CROSSTREK

**KA-5465 8pcs Head Gasket Alignment Tool (VAG)**

- For VAG engines to align the gasket.
- These pin allow the mechanic to place the gasket on the block accurately.
- Application: Beetle 2.0L (1999-2004)
- OEM No. 3450 (3450-1, 3450-2, 3450-2A, 3450-3)
- Contents:
  - 1pc M6 x 1.0mm pin extraction tool
  - 1pc M6 x 1.0mm pin extraction tool (no handle)
  - 2pcs M10 x 1.5mm long pin
  - 2pcs M9 x 1.25mm long pin
  - 2pcs M10 x 1.5mm short pin

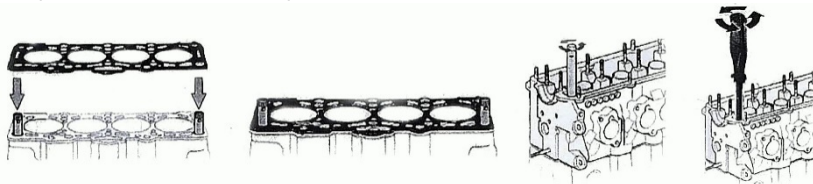

**KA-5466 Subframe Alignment Pins**

- Ensure correct alignment of subframe, suspension and steering components.
- Application: for a wide range of Ford.
  - Vehicles-including: C-MAX, COUGAR, ESCORT, FIESTA, FOCUS, FUSION, GALAXY, KUGA, MONDEO, ORION, PUMA, S-MAX, TOURNEO CONNECT, TRANSIT, TRANSIT CONNECT, TRANSIT CUSTOM.
- Equivalent to OEM 205-316A.

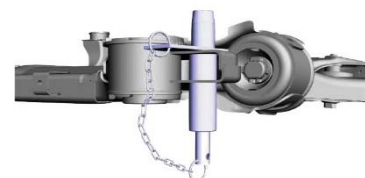

**KA-7846 HOG RING PLIERS SET**

For closing hog rings to repair passengers car sets. Suits each type of vehicle use.



**KA-3805 Drum Brake Shoe Spreading Tool**

- Adapt to 3/8" Dr. and 14mm Hex allowing use of a ratchet or spanner.
- Brake shoe spreader range 18mm to 105mm.
- Spreads and hold the brake shoes apart allowing removal of the brake cylinder, etc.
- Eliminates the need to remove the brake shoes or apply the handbrake.
- Eliminates the need to dismantle the brake shoe assembly leaving hands free to work

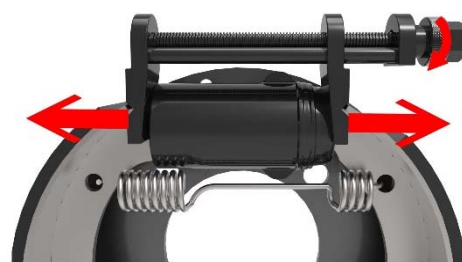

**KA-3830 Adjustable Ball Joint Separator**

- Used for removing many ball joints and tie rod ends.
- Features a rust resistant finish.
- A handle for use with hammer.
- Adjustable jaws width: 18mm to 43mm.







**KA-4136 3/8" Dr. Spark Plug Thread Chaser (M14 x 1.25)**

- Made of high strength chrome vanadium steel.
- Works on 3/8" Dr. M14 x 1.25mm spark plug threads.
- Manganese phosphate coating prevents rust.
- Low profile design and narrow profile, and long length make it ideal for hard to reach areas.



**KA-4137 3/8" Dr. Fuel Injector Line Socket (19 & 22mm)**

- Designed to easily torque the fuel injector lines correctly, reducing if not eliminating the possibility of a fuel leak or damaging the line, fuel rail or fittings.
- Easily applies the factory required torque of 30 ft-lb.
- No torque adaptors with complicated calculations required.
- Use on cummins ISB engines 1998 to present.
- 19 & 22mm, 3/8" drive.



**KA-3831 Valve Spring Compressor For GM LS**

- Works on most GM LS-Type engines.
- Allows removal of the valve spring without removing the rocket stand or other rockers.
- Can be used on or off the vehicle.



**KA-4103A Harmonic Balancer Puller**

- Tool fits securely into cast slots of harmonic balancer enabling easy removal even with radiator in place.
- The only harmonic balancer puller designed for most of 6 cylinder vehicles.



**KA-4138 Rear Hub Socket - Toyota Land Cruiser**

- Application: Toyota Land Cruiser including GXL Advantage, Blue Marlin, Blue Marlin GXL - Full details on website.
- 1/2" Dr. 55mm deep with 3 spoke profile x 7.5mm diameter plus 3 x 15mm slotted grooves.

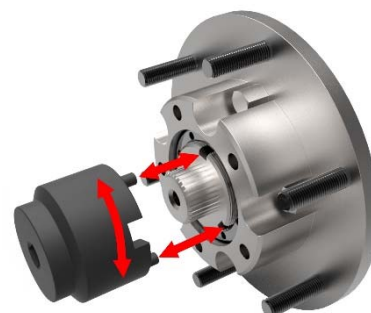

**KA-4139 Hub Nut Socket**



**Application to:**

- 2006 (Ram Truck) - System (3 - Differential and Driveline)
- 2007 (Ram Truck) - System (3 - Differential and Driveline)
- 2008 (Ram Truck) - System (3 - Differential and Driveline)
- 2009 (Ram Truck 2500/3500) - System (3 - Differential and Driveline)
- 2010 (Ram Truck Cab Chassis, Ram Truck 4500, Ram Truck 1500) - System (3 - Differential and Driveline)
- 2011 (Ram Truck 1500) - System (3 - Differential and Driveline)
- 2012 (Ram Truck 1500) - System (3 - Differential and Driveline)
- 2013 (Ram Truck 3500, Ram Truck Heavy Duty, Ram Truck Cab Chassis, Ram Truck 4500, Ram Truck 2500) - System (3 - Differential and Driveline)
- 2014 (Ram Truck 3500, Ram Truck Heavy Duty, Ram Truck Cab Chassis, Ram Truck 4500, Ram Truck 2500, Ram Truck 4500/5500 Cab Chassis) - System (3 - Differential and Driveline)



**KA-6253B**



**KA-6261C**

**Oxygen Sensors Socket – Thin Wall**

Oxygen sensors that cannot be accessed with standard sockets.

**KA-6253B** 1/2"Dr. x 7/8"(22mm) x 90mmL

**KA-6261C** 3/8"Dr. x 7/8"(22mm) x 80mmL



**KA-2203A Clutch Alignment Tool for MINI**

- The clutch alignment tool is used to install a new clutch in the manual transmission.
- OEM Ref. 21 6 100 (83 30 0 493 999)

Make	Model	Submodel	Engine
MINI	Cooper	Base	L4 1.6L W10B16A



**KA-2203B Clutch Alignment Tool for MINI**

- The clutch alignment tool is used to install a new clutch in the manual transmission.
- OEM Ref. 21 2 210 (83 30 0 494 261)

Make	Model	Submodel	Engine
MINI	All	John Cooper Works GP	All
MINI	All	John Cooper Works MC40	All
MINI	All	S	All



**KA-4520 Diesel Injector Seal Puller**

- A specialized tool, used to assist the extraction of the copper washers used to seal diesel injectors where they enter the cylinder head.
- Commercial vehicles used.
- These sealing washers sit at the bottom of the injector orifice and are a common failure point. They are so deep into the cylinder head and usually stuck tight with carbon build-up that extraction is usually next to impossible.





### KA-4509 Cylinder Sleeve Puller Set

- With support and slide hammer.
- For removing wet type cylinder sleeve Ø3" to 6-1/2".
- Cone adjustment positions the puller jaws quickly, locking bar is tightened.
- To aid in breaking sleeves loose, adjustable bridge is positioned on the cylinder block and the bearing mounted forcing nut is tightened.
- Next, bridge is removed and slide hammer assembly is attached.
- With a few sharp hammer blows, sleeve is pulled.

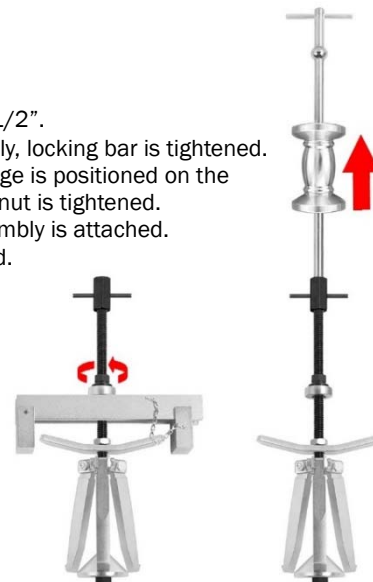

### KA-4518 Cylinder Liner Puller With Support

- For removing wet cylinder liners from engines used on passenger cars and trucks (Mercedes, MAN).
- Suitable for cylinder liner Ø60~160mm.

**Operation:**

1. Screw the spindle of the support into the clamping nut of the puller.
2. Insert the puller into the liner.
3. Place the support on the cylinder block.
4. Tighten the nut of the support.

*\* Thanks to the newly developed spreading system, turning the spindle will enable all three jaws to spread quickly and without any trouble until they are firmly seated beneath the edge of the liner.*



### KA-7847 Universal Brake Refilling Adapter

- Brake refilling adapter with a 90° rotating coupling fits almost all vehicles on the market.
- Fits master cylinder fill neck between Ø28-70mm (1.10"-2.75").
- Maximum pressure up to 3.5 bar (50psi).
- Brake fluid resistant EPDM rubber.

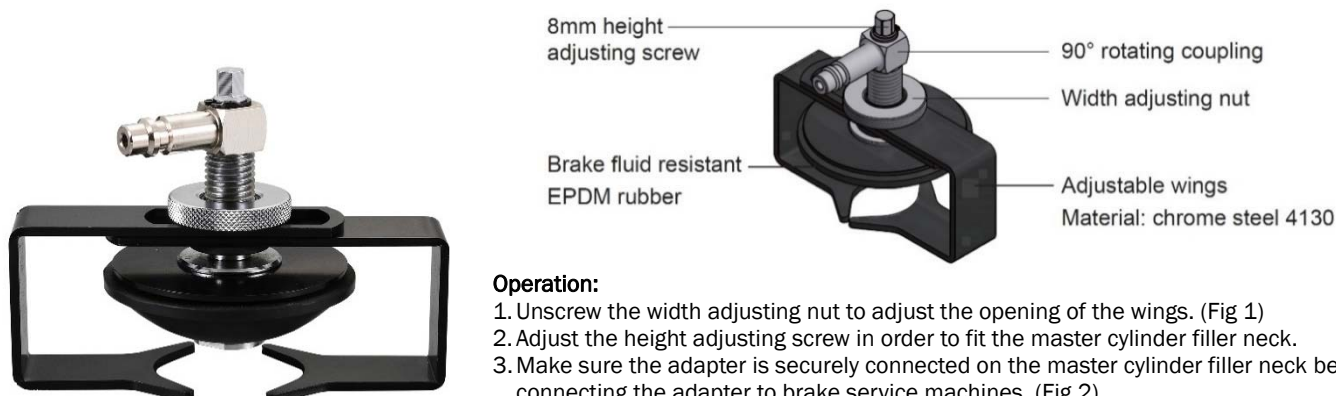

**Operation:**

1. Unscrew the width adjusting nut to adjust the opening of the wings. (Fig 1)
2. Adjust the height adjusting screw in order to fit the master cylinder filler neck.
3. Make sure the adapter is securely connected on the master cylinder filler neck before connecting the adapter to brake service machines. (Fig 2)



### Air Line Disconnect Pliers

Disconnects the air line quick connector on heavy- duty vehicle air brake system.



#### KA-5264

- Easy loosening of air lines with diameters 6, 8, 10, 12mm
- Ideal for the **straight** air line quick connector.

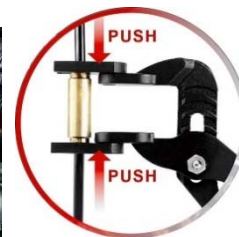

#### KA-5264A

- Easy loosening of air lines with diameters 6, 8, 10, 12, 15, 16mm
- Ideal for the **elbow** air line quick connector.

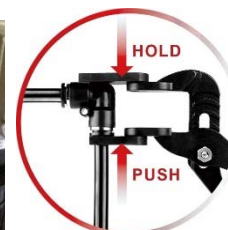

### KA-4519

#### Crankshaft Pulley Flange Holding Tool For 1.3L JTD / Multijet

- For counter holding the oil pump drive flange.



#### Application:

Manufacturer	Model	Manufacturer	Model
Fiat (JTD)	500 / 500C	Ford (TDCi)	Ka
	Panda / Panda Classic	Opel	Agila / Agila-B
	Punto / Punto Classic	Vauxhall	Corsa-C / Combo-D
	Punto Evo	Holden	Corsa-C / Corsa-D
	Grande Punto	(CDTi)	Meriva-A / Meriva-B
	Qubo		Astra-H / Astra-J
	Doblo / Dobloc Cargo		Tigra-B
	Idea	Suzuki (DDiS)	Swift
	Linea		Ignis
	Fiorino		Wagon R+
	Strada Pickup		Splash
Lancia (JTD)	Ypsilon	Peugot (HDi)	Bipper
	Musa	Citroen (HDi)	Nemo
Alfa Romeo (JTD)	MiTo		

### KA-6592A Assembly Lever and Guide Pin – Mechatronic

- For DSG OAM / DQ200
- To operate the engaging lever and guide the mechatronic component during dismantling and mounting jobs of the mechatronic unit on 7-speed dual clutch gearbox OAM.
- OEM Ref. T10407 / T10406

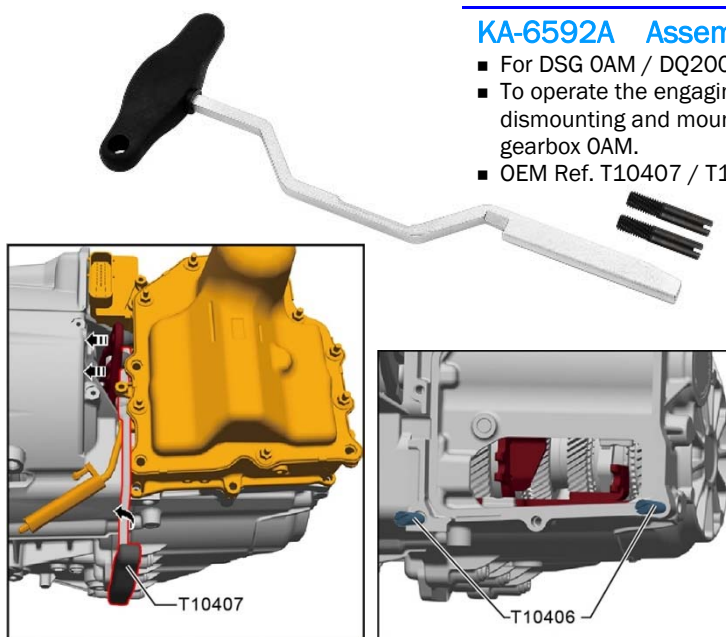

Audi	A3 2004>
VW	Golf 2004>, Golf 2009>, Golf Plus 2005>, Golf Variant 2007>, Golf Variant 2010>, Polo 2009>, Polo 2014>, Scirocco 2009>, Jetta 2005>, Jetta 2011>, Passat 2006>, Passat CC 2009>, Touran 2004>, Eos 2006>
SEAT	Altea 2005>, Altea 2009>, Toledo 2005>, Toledo 2013>, Leon 2006>, Leon 2009>, Leon 2013>, Altea XL 2007>, Altea XL 2009>, Altea Freetrack 2007>, Altea Freetrack 2009>, Ibiza 2008>
Skoda	Fabia 2007>, Octavia 2004>



## KA-6870

### Adjustable Hook And Pin Wrench Set

- Hardened and tempered drop-forged Chrome Vanadium steel.
- Specially designed for use with slotted retaining rings.
- Hook and pin interchangeable hinged arms with three wrenches covering sizes 19-120mm (3/4"~4-3/4").
- Pin Sizes: Ø4-8mm.
- Supplied in tough storage case.
- Designed for use on slotted retaining rings found on motorcycle suspension and other machinery.
- Time saver.



## KA-4000

### Long Reach Harmonic Balancer Installer for Ford EcoBoost

- This tool is perfect for hard to enter areas, particularly on FWD vehicles.
- Easily assemble the harmonic balancer on to the crankshaft of multiple Ford EcoBoost engines
- The tool was designed for easy installation of harmonic balancers of Ford EcoBoost and various other Ford/ Lincoln engines from 2011 till now.
- Applications: 2.7L, 3.0L, 3.3 L, and 5.0L engines in Ford/Lincoln cars, trucks, and SUVs.

## KA-4143 A/C Clamp Remover

- Fits both high and low edge clamps.
- Suitable chamfer opens clamps.
- For dismantling line clamps found on Toyota Tacoma (2015-2018).

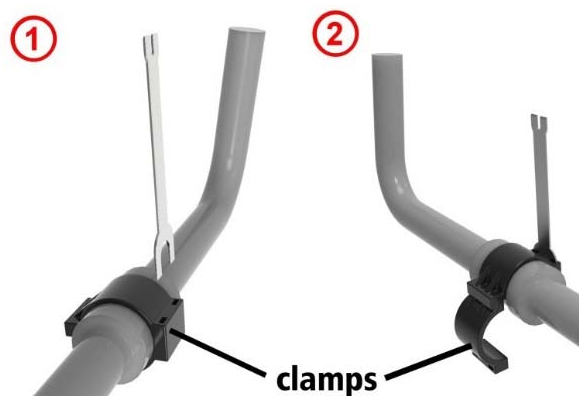
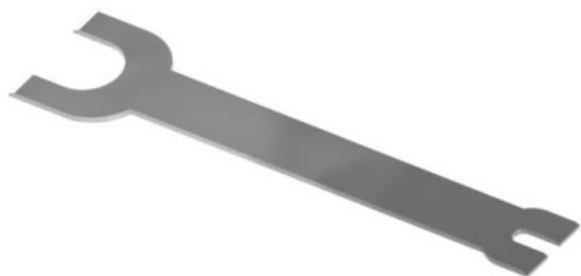

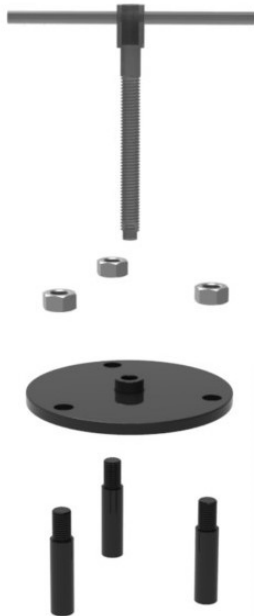

**KA-3663Q 6 Holes Hub Separator**

- Removing the 6 holes HUB rear axle.
- Save Labor and Working time. .
- Application :TOYOTA HIACE 100 series, 200 series, NISSAN CARAVAN E25,series,E26 series.
- P.C.D:139.7mm
- Thread specification:M12X1.5



**KA-3663Q2 6 Holes Hub Separator**

- Removing the 6 holes HUB rear axle.
- Provides the mechanical advantage.
- For Disc brakes
- P.C.D:139.7mm
- Application: TOYOTA HIACE 100 series, 200 series NISSAN CARAVAN E25 series, E26 series



**KA-6397A Master Freeze Plug Installer Kit**

- Forged with S45C and fully-plated to prevent rust.
- Designed to dismantle and assemble freeze plugs used in liquid-cooled gas and diesel engines.
- Content:
  - 2 Knurled Shafts (8" and Angled 18")
  - Knurled Ring Nut End: 3/4", 1", 1-1/4", 1-1/2", and 1-3/4"
- No Need to dismantle head or manifold again.

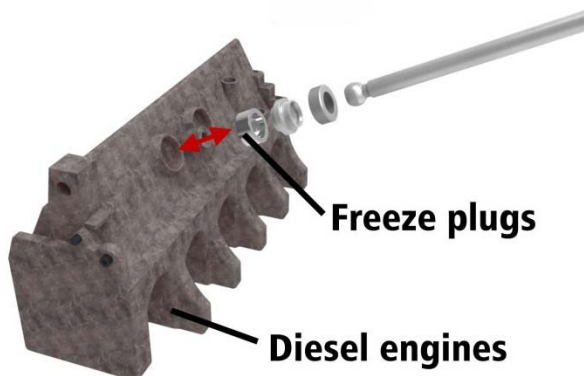



- 1. On/Off Switch
- 2. Power Indicator (Green)
- 3. Start Heating Button



- 4. Heating Indicator (Yellow)

- 5. Baby Oil Inlet
- 6. Fuse (8A)
- 7. DC 12 Power Connector
- 8. Smoke Outlet



### KA-9073A Smoke Leak Detector Set

A Great Tool to trace any leaks in automotive pipe systems such as air intake, fuel system, exhaust system, vacuum system.

**Step 1.** Connect the 12V Car Battery:

- Clip the **RED** battery to the positive pole (+).
- Clip the **BLACK** battery to the negative (-).

**Step 2.** Switch ① the power (ON):

The ② Power Indicator turn **GREEN**.

(If you connect the pole wrongly, the **YELLOW** light would on)

- The machine is equipped with protection device , so it will not be damaged if connect pole incorrectly.
- If you are using this machine for the **FIRST** time, please inject 1-2ml baby oil in ⑤ Baby Oil Inlet. Then fill 0.5-1ml for each time.
- **Please use Baby Oil ONLY!!**

**Step 3.** Start Heating to Produce Smoke:

Press the ③ Start Heating Button, ④ Heating Indicator light turns **YELLOW**.

It would reach workable smoke volume after **90** seconds, then press the ③ Heating Button again to stop heating.

- The machine would stop automatically after 5 minutes . Repeat Step 4 as needed, and fill baby oil according the smoke.
- Clean the Smoke Tube with dust gun after each use. The residue hardening baby oil cause clogs in tube.

Rubber Pipe Plug



Inflate Ball Stopper



Power Cord



Smoke Tube



Baby Oil (200ml)





### KA-2216 Spot Weld Chisel

- Flat Splitting tool for the Manual Cutting of Spot Welds.
- For Panel Splitting
- THICKNESS:7.5MM, WIDTH: 26MM, LENGTH:240MM, Great to use with Hammer
- Made of CR-MOLY
- Hardened and Tempered.



### KA-1366 Turbo Power Foam Gun

- Produce Rich and fluffy Foam that “Wrap” the dirt to Remove the Dirt easily and completely.
- Remove the Automotive/Motorcycle/Scooter body dirt and stain easily.
- Professional Automobile Detailing
- Excellent for Construction/Building/Wall Bricks/Wall Dirt Removal
- Fast and Efficient.

#### Feature:

1. Light and Durable Aluminum Housing.
2. Max Pressure: 15 Bar
3. Large Volume: 1000ml

Working Pressure	0.3~1.5Mpa(3~15Bar)
Material	Body:Aluminum alloy Bottle: HDPE (1000 ml)
Port size	¼ G
Air Consumption	8Bar≥300L/M
Temp Range	-5~+60°c (Non frozen)
Shooting Range	2.5M (inlet 5Bar)

### KA-5388 TOYOTA,LEXUS FUEL TANK LID TOOL

- Remove and Assemble the fuel tank lock rings.
- For most TOYOTA and LEXUS Vehicles
- Size: 1/2" DR x 24PT.
- Applicable: TOYOTA, Corolla, Land Cruiser, Matrix, Tacoma, Yaris S, Yaris Base, VIOS

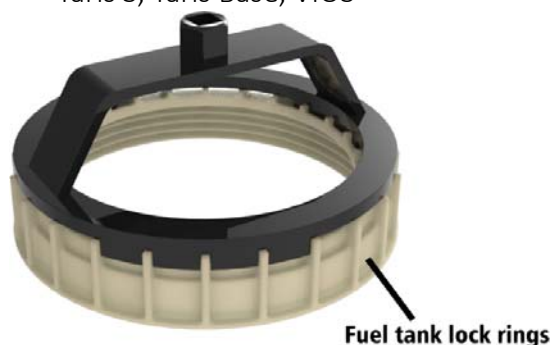



## KA-5062

## HEAVY DUTY HYDRAULIC VALVE LIFTER REMOVER

- Knurled handle for firm and anti-fatigue grip.
- Specially designed slide hammer easily tight firm or struck lifters.
- Expandable Collets to firmly grasp the hydraulic valve lifters.

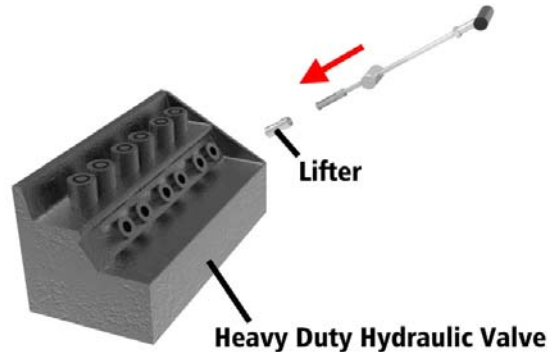

## KA-1375 SPINDLE SNAP RING PLIERS FOR FORD SUPER DUTYK

- Ratcheting lock mechanism holds the snap ring open for plain extraction and installation.
- For changing the spindle snap rings found on 2007 and newer Ford Super Duty Pickups.
- Install snap ring within 2-1/2" diameter of the hub.
- Rigid plier device.
- Slender thin tips provide easy installation.

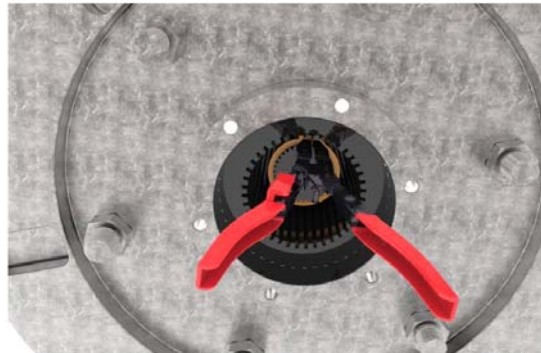

## KA-3277C

## Push Pin Pliers – Flat Degree

- Designed to remove center locking pin type fasteners.
- Improved access to tight places.
- Prevents damage to fasteners and surrounding trim.
- Ergonomic coated handle prevents fatigue during long use.
- Applications: Chrysler, Honda, Toyota, GM, Ford and other late model vehicles.
- Also Available:
  - KA-3277: 30 Degree Push Pin Pliers
  - KA-3277A: 80 Degree Push Pin Pliers

## KA-3935A SPINDLE SNAP RING PLIERS FOR FORD SUPER DUTY

- 1/2" Drive
- Use this socket with Breaker bar or Drive Ratchet.
- This non-marring, aluminum tool revolves the crankshaft in correct direction, when the balancer is off.
- Easy Installation

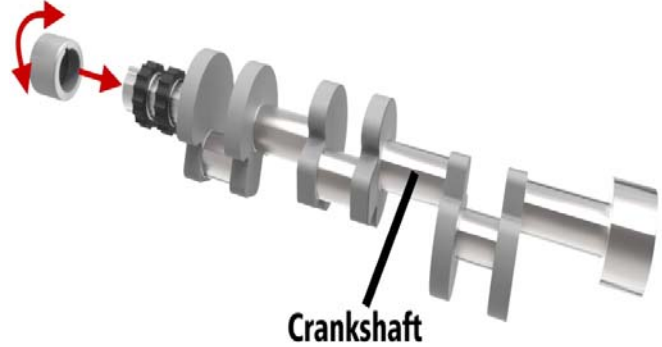

## KA-2217

### Wheel Bolt Lock Socket Set (10 pcs/set)

### For Tesla Vehicles

- This tool enables you to permit servicing of customer vehicles, even customer has lost the key.
- Content: #76, #77, #78, #79, #80, #81, #82, #83, #84, #85

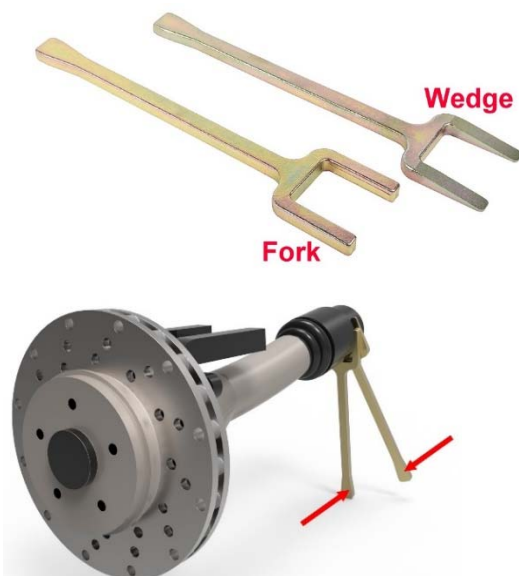

## KA-2210AB Axle Popper Kit

- Fork Design Applying Even Pressure to Both Sides of the Shaft and Allow Removing the Shaft Easier and Safer.
- To release the half shaft:
- Strike the Axle Popper Wedge or use Axle Popper Wedge as a Pry Bar to Release the Half Shaft
- Shim included for use on filling the gap between the half shaft and trans-axle
- Safer than Using Pry Bar
- CONTENT: Fork Shaped Axle Popper, Axle Popper Wedge

## KA-2212 Ball Joint Service Kit



- Special designed for the removal and installation of press fit parts ball joints, without having to resort to makeshift methods.
- The ball joint service kit is applicable to Sportsman XP, RZR and Ranger models.
- Made from high quality steel that will resist the high pressures involved with ball joint service.
- This tool exactly squeezes the new ball joint into place without damage.

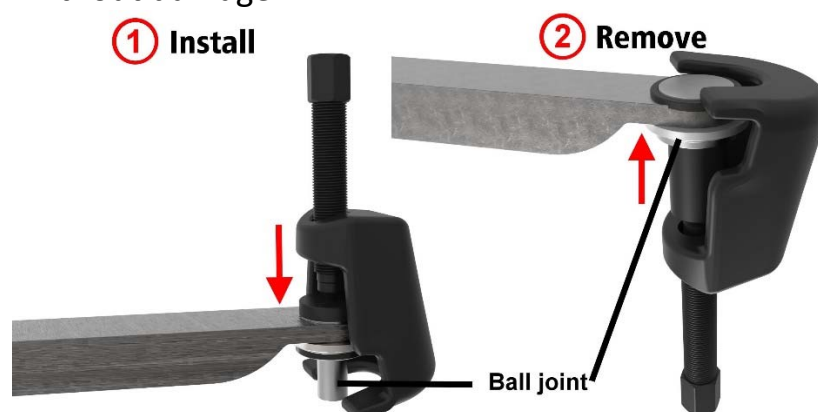

## KA-2213 Lower Arm Ball Joint Separator



- Forged steel body and lever provide an excellent performance and long usage.
- This press segregates the lower control arm ball joint from the steering knuckle.

- Jaw open: 60mm
- Works on many Ford, Lincoln.
- Works on Mercury Milan model years 2006, 2007, 2008, 2009, 2010 and 2011.
- Works on Montego model years 2005, 2006 and 2007.

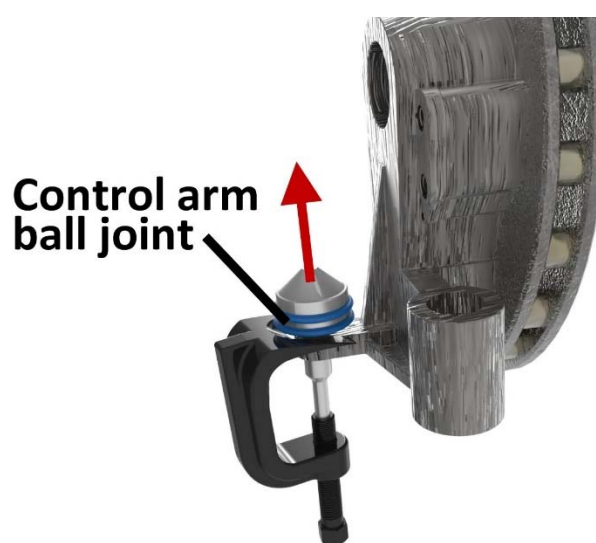

## KA-2214 Harmonic Dampening Tool



- Keep crank pulley still avoid the harmonic damper pulley from revolving in the course of moving and installing the conclusive torque specification on the pulley bolt, allowing users to easily remove and install the crank bolt on many Toyota & Lexus engines.
- Grips the crankshaft while tightening the crank bolt.
- To tighten crankshaft pulley by 2 screws (M8 x1.25).
- Extend work needs 1/2" Dr. wrench.

## KA-2215 1/2" dr. NV4500HD Mainshaft 5TH Gear Nut Wrench For Dodge



- Made of good quality steel.
- Mainshaft 5th gear nut wrench is a requisite to remove or assemble the mainshaft nut.
- It fits for NV4500HD transference used in Cummins and V10 powered Dodge RAM models have a large diameter mainshaft nut.
- It fits for 1994-2001 Dodge NV4500HD



### KA-2209A Crank Pulley Bolt Wrench

- It is a set that fixes the crankshaft pulley of SUZUKI, motor and can detach the crankshaft pulley bolt.
- This special tool has been made extremely thin in consideration of the narrowness of the engine room specific to mini vehicles.
- When tightening the crankshaft pulley bolt, a torque wrench can be used, but be careful of the tightening torque value.
- Application:  
WAGON R: LA-MH21S / ABA-MH21S / CBA-MH21S, 22S / UA-MH21S  
CERVO: CBA-HG21S / DBA-HG21S  
MR WAGON: CBA-MF22S, JIMNY: ABA-JB23W



### KA-1134PPS Small Piercing Probe

- Stainless steel tip can connect with the wire without cutting it.
- With 4mm socket connection.
- Wire: 20~28 Gauge
- Current Rating: 10.0 Amp

### KA-1135PPL Large Piercing Probe

- Stainless steel tip can connect with the wire without cutting it.
- With 4mm socket connection.
- Wire: 8~18 Gauge
- Current Rating: 20.0 Amp



### FLEXIBLE 10 GAUGE LEADS

- KA-1130-1FT Length: 1ft
- KA-1130-3FT Length: 3ft
- KA-1130-6FT Length: 6ft

## KA-5478 Adjustable Spark Plug Wire Puller

- Plier Jaws Adjustable to Five Different Angles/positions.
- Special Cushioned and Shaped Jaws gripping the Spark Plug Boots straight on or from other sides or any sides perfectly
- Plastic Handle Grip to avoid shock.
- Make SPARK PLUG BOOTS repair Easier!!



## KA-5479 Hydraulic Truck Floating Brake Disc Dismantling Set

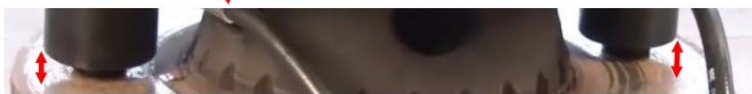
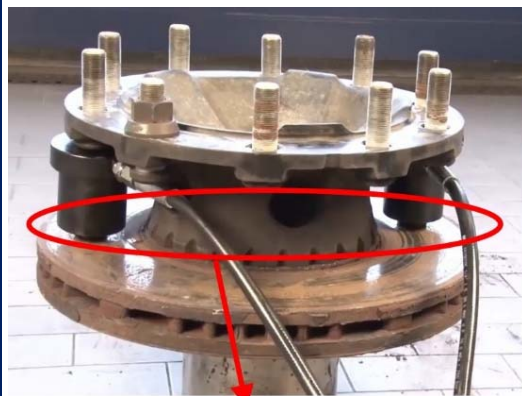

- While changing truck floating brake disc (such as Volvo, DAF etc.), the brake discs always get stuck caused by rust or dust and hard to remove/dismantle.
- This set comes with two compact 14T hydraulic cylinders operated by a control block with individual on/off switch which allow the operators control one cylinder at a time to safely and effectively dismantle a stuck brake disc.
- Due to the compact size of the hydraulic cylinder, this set can be used not only on this purpose but also on those works which limited by space but need effectively expanding requirement.
- Applications include: The trucks equipped with floating brake discs such as Volvo, DAF, Renault, etc.

## KA-3818P 2 in 1 Molding Strip Tool

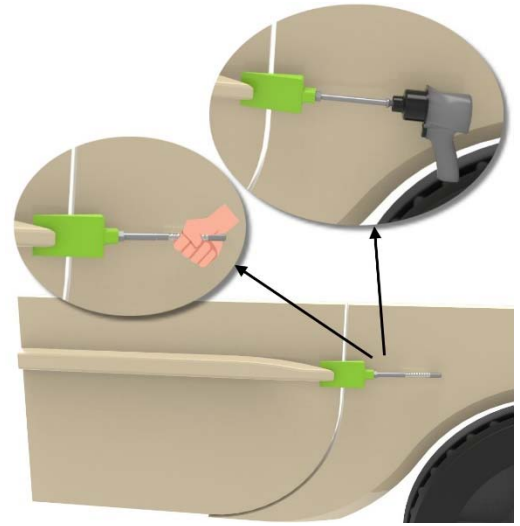

- Plastic Blade is Non-Marring and it won't Damage the Molding nor Scratch the Vehicle Body Paints.
- Wedge Angle Remove / Separate the Double-Sided Tape from the Door and Vehicle Body.
- Plastic Blade made with High Impact POM Structure Allowing Rigid Application with Mallet / Hammer.
- Pointed Wedge Edge Enables to be used under The Door Molding and Emblems.
- Attach the Plastic Blade with Impact Handle when using with Air Gun.
- Content: Plastic Blade, Manual Handle, Handle Shaft for Air Gun

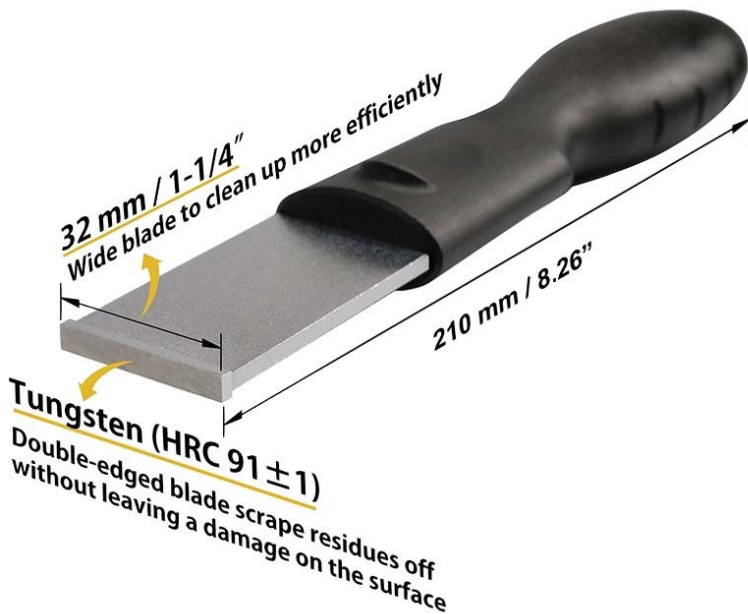

## KA-4531 Super Scraper

- To scrape off old silicone on oil pans, carbon buildup on exhaust manifolds, or rusts on brake calipers.
- Finely ground carbide double edges scrape residues off without leaving a damage on the surface.
- Premium tungsten carbide tip remains sharp for an extended period of time.
- Ergonomic handle design offers comfortable grip.

## KA-2210AB Axle Popper Kit

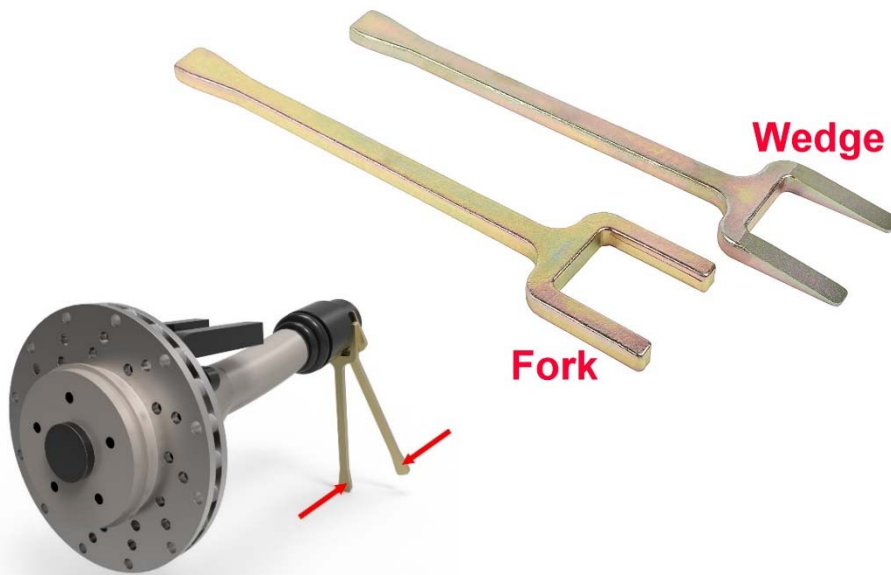

- Fork Design Applying Even Pressure to Both Sides of the Shaft and Allow Removing the Shaft Easier and Safer.
- To release the half shaft:
- Strike the Axle Popper Wedge or use Axle Popper Wedge as a Pry Bar to Release the Half Shaft
- Shim included for use on filling the gap between the half shaft and trans-axle
- Safer than Using Pry Bar
- CONTENT: Fork Shaped Axle Popper, Axle Popper Wedge

## KA-2210K Axle Popper Kit



- CONTENT: Fork Shape Pry Tool, Wedge Tool, Shaft (for Air Hammer)
- Fork Design Applying Even Pressure to Both Sides of the Shaft and Allow Removing the Shaft Easier and Safer.
- Tapered on Both Wedge Ends.
- Attach the shaft to Wedge to use with Air Hammer.
- Can be used with KA-2210AB.



## KA-3170A 2 in 1 Fuel Tank Lock Ring Kit



- An Innovative Great Tool with Multi-Application:
- Damage-Free to Remove and Re-Fit the Fuel Gauge Sender Collars.
- Easy to Remove and Install Lock Ring on the Fuel Tank when Servicing the Fuel Pump or Fuel Sending Unit.
- 2 Sets of Interchangeable Legs
- Channel Design body bar enable the Interchangeable Legs to Lock and Fit in Place to Secure the Drive Centered.
- Compact Size to Prevent Hanging over the Work Area and Eliminate the Possibility of Damaging other Parts
- Operation Range: Diameter 90-170mm
- Content: Channel Center Bar & 2 Interchangeable Set of Legs.



## KA-2211 Fuel Tank Lock Ring Wrench

- Great design allows tool to fit fuel tank lock rings on Ford, Chrysler, GM vehicles.
- Easily removes and installs lock ring on the fuel tank when servicing the fuel pump or fuel sending unit
- Application: 2004-newer Ford F-150 trucks. 2004-newer Chrysler / Dodge mini-vans, PT Cruiser, Dakota, Durango. 2004-newer Chevy 1/2-ton and 3/4-ton trucks.
- Used with a 1/2" Dr Ratchet or breaker bar.



## KA-8093 Sonic Belt Tension Meter

The sonic belt tension meter is able to measure the vibration of the belt from the microphone in the front. The meter will then use the mathematical calculation to convert the tension from the vibration of the belt, Which is helpful for installation or tuning of any belts.

### Features:

- Portable Probe
- 20 sets Frequency Storage
- Maximum Frequency: 600Hz
- Automatically Power-off: The instrument will automatically power off when no operation for 5 minutes.
- User can also make the instrument power off by pressing On/Off switch for 2s.
- Power Source: 2 X AAA Battery

## KA-1074 Injector Tester



- Replaceable connector for different terminal.
- Power source: 12V vehicle battery.
- Operation environment: 0-40°C ; < 80% RH Storage.
- Environment: -10°C ~50°C ; < 85%RH.
- The tester can help diagnose injector problems, you can use it to test each injector individually to help identify **stuck**, **leaking** or **burnt-out** conditions.

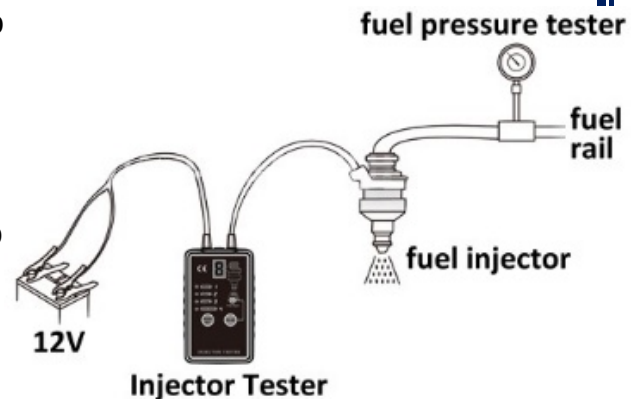

## KA-1075 Glow Plug Tester

- 6 LED to indicate the operating state of glow plug.
- Test without removing glow plug from engine.
- Power source: 12V vehicle battery.
- Indicate the condition of Short Circuit, Fault, OK, High Resistance, Open Circuit and Low Battery.

## KA-8092 Performance Tool Flywheel Turner



- Spring Tension Stabilizing the Tool on the Flywheel and Flex-Plate, Allowing Free use with Both Hands.
- Stabilize the Flywheel or Flex-Plate when Torqueing the Harmonic Balance Bolts or Flywheel.
- The Tools Folds for easy storage
- Easily Turn and Rotate the Engine from Underneath the Vehicle.

Flywheel



## KA-3761G Plastic Oil Drain Plug Tool Kit

A comprehensive 2pc kit specially designed to fit plastic oil drain screw plugs on popular commercial vehicles and passenger cars, such as DAF, MAN/NEOPLAN and Mercedes Benz. Sliding T-handle and interchangeable design provides extra leverage and easy-change direction and quickly changed from one to the other tool.

### Application:

DAF: 1853 604, 1982 821

MAN/NEOPLAN: 51.90310.6010

Mercedes-Benz OEM A 0029902017

Or some other vehicles fitted with same screw plugs.

Individual tool available upon request.



## KA-3886A 1/2" Dr. GM Water Pump Socket Disc Brake Pad Spreader

- Angled Teeth Prevent the Tool from Gliding.
- Remove and Install the Water Pump Assembly
- Application:  
1993-Current North Star 4.6 Liter,  
1997-Current Aurora 4.0 Liter
- 1/2" Drive size.

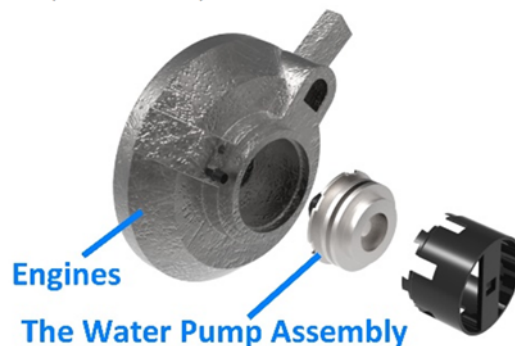

## KA-3821A Gear For Engine Flywheel Rotation

- System for dual gear engine flywheel rotation for IVECO timing search
- Engine models: 8040-25-45 / 8060-25-45 / 8460 / 8260 / 8280 / 8210.42 / 190.38 / 190.42
- Specific for Euro Cargo / Cargo Eurotech / Heavyon/ Off Road / Bus
- 2 gears



## KA-3821B Gear For Engine Flywheel Rotation

- For dual gear engine flywheel rotation for timing.
- Suitable for IVECO models
- Engine models: 8360.46 / F3A / F3B
- Suitable for Euro Cargo / Cargo 150E27R PR / FPR 320E27T / PT Euro tech / Eurostar models.

## KA-1358UVC Rechargeable UVC Disinfection Lamp

**Features:**

- Widely used in the disinfection of the surface of objects without any damage.
- Easy & Simple to operate and carry on.
- Easily kills airborne viruses while posing no risk to people.
- 20 Seconds the light will be automatically turned off to avoid long-term UVC exposure.
- Kill 99% Germs in 20 seconds < 3cm.



Made in Taiwan  
Panasonic Lithium-Ion battery



**Noticed:**  
Do not light on eye or skin direct

**Specification:**

Wavelength	270~285nm
Lamp bead Angle	120°
Radiation Power	8~15mW
Battery	18650 Li-ion 3.6V Rechargeable
Storage Temperature	-30°C to 60°C
Operation Temperature	-40°C to 80°C
Action Time	Up to 3 hours +
Charge Time	2 hours (DC 5V2A)
LED Charging Indicator	Red Light On - in charging Green Light on - completely charged
Product Size	215(L) x 27(W) x 30(H) mm
Weight	130g

**Application:**



Ultraviolet light with a wavelength of 240~280nm that can destroy the DNA of bacteria or the molecular structure of PNA, kill the germs completely.

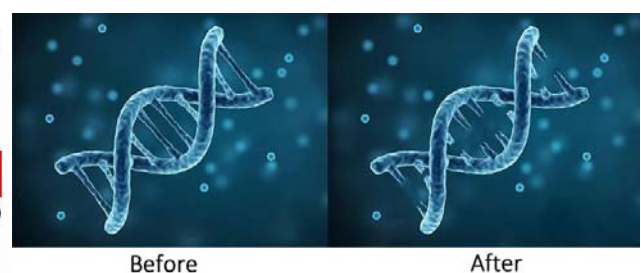
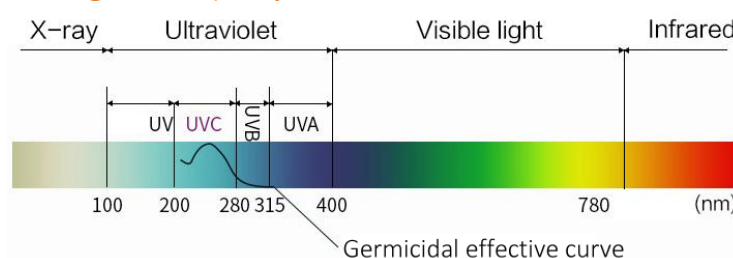



## KA-6787

### Aluminum Body Hammer Set

Aluminum hammers help prevent cross contamination on aluminum bodied vehicles. Aluminum hammers provide more forgiving strike than other hammers, avoiding further damage to aluminum panels.



#### Contents:

KA-6787-01	Aluminum Round large head hammer		
KA-6787-02R	Aluminum Pein / Finishing Hammer	Horizontal	Large
KA-6787-02S	Aluminum Pein / Finishing Hammer	Vertical	Large
KA-6787-03R	Aluminum Pein / Finishing Hammer	Horizontal	Medium
KA-6787-03S	Aluminum Pein / Finishing Hammer	Vertical	Medium
KA-6787-04R	Aluminum Pein / Finishing Hammer	Horizontal	Small Rubber Cap
KA-6787-04S	Aluminum Pein / Finishing Hammer	Vertical	Small Rubber Cap
KA-6787-05	Aluminum Bumping Hammer		
KA-6787-06	Aluminum Pick / Finishing Hammer		

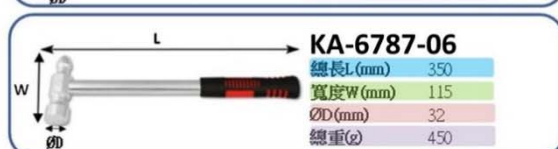



### KA-3816 Aluminum Body Hammer & Dolly Set

- Aluminum hammers help prevent coss contamination / provide more forgiving strike on aluminum bodied vehicles.
- Rubber dollies provide a lighter option when accessing a tight, confined location behind an aluminum panel.

**Contents:**

Item No.	Description
1 KA-6787-02RS	Aluminum Pein / Finishing Hammer (Vertical - Large)
2 KA-6787-05	Aluminum Bumping Hammer
3 KA-2890L	Rubber Heel Dolly
4 KA-6685	Rubber General Purpose Dolly
5 KA-2890F	Rubber Toe Dolly

### Push Pin Pliers

- Designed for the removal of push pin plastic body fasteners and clips with center locking pin.
- Removes locking pin without damage to pin or anchor.



KA-9285		KA-9285-90		KA-9285A	
4-groove		2-groove		O-groove	
				3-groove	
				Nissan, Infiniti, etc...	

KA-3817A  
Wedge-shaped handle



KA-3817B  
Round-Shaped handle

## KA-3817 One Hand Jack Tool Set

→ Use this pry-style tool to create enough space to easily insert the air wedge without damaging the vehicle.



It uses a rubber pivot to provide leverage to create working room to insert the air wedge.



KA-3818A  
with handle

KA-3818B  
without handle



## KA-3818 Molding Strip Wedge Set

- The tool with 3" non-marring blade allows the technician to remove body side moldings and emblems quick and clean.
- KA-3818A with durable plastic handle can be hit with a hammer.
- Won't mark or scratch vehicle finish.
- Also for the basic opening of car door for insertion of lock our tools.





KA-6348S



KA-6348M

### Universal Thread Repair Tool

- One tool restores inch or metric RH or LH threads.
- No calibration required.
- Self adjusting to any pitch & size within range.
- Automatically chases good threads to repair the damage.
- 60°, ISO, UNC, UNF, NPT
- 55°, BSW, BSF, BSP



<b>KA-6348S</b>	<ul style="list-style-type: none"> <li>■ 5/32"~3/4" (4~19mm)</li> <li>■ Pipe threads up to 7/16"</li> </ul>
<b>KA-6348M</b>	<ul style="list-style-type: none"> <li>■ 11/16"~1-1/2" (17~38mm)</li> <li>■ Pipe threads 3/8"~1-1/8"</li> </ul>



### KA-6348J Universal Adjustable Thread Repair Tool

- Quickly adjustable to any thread diameter & pitch within the size range indicated.
- Applicable to most thread standards – ISO, UNF, UNC, NPT, BSW, BSP & more 2 cutting blades (58RC) guided by the existing thread, re-groove the damaged part.
- No prior thread measuring is needed.
- Range: 35~152mm (1-3/8"~6")
- Pitch: 1"~5-1/2"



### KA-5469

## Locking Wheel Bolt Removal Tool Kit (Spinning Collar)

- Fits BMW / MINI vehicles equipped with the spinning collar locking wheel bolt.
- To remove the ultra high security locking wheel bolt with spinning collar which is stuck from being overtightened, rounded, stripped or the key is broken / missing.
- M16 x 1.5 (with slide hammer).

McGard 27179SL (M12x1.5)	
BMW	Serie 1 (~2011)
	Serie 3 (~2011)
	Serie 5
	Serie 6 (~2010)
	Serie 7 (~2011)
	Serie 8
	X1
	Z1
	Z3
	Z4
Z8	
McGard 27226SL (M14 x 1.25)	
BMW	Serie (2011~)
	Serie 2
	Serie 3 (2012~)
	Seris 3-GT
	Seris 4
	Serie 5-GT
	Serie 6 (2011~)
	Serie 7 (2008~)
	X3 (2010~)
	X4
	X5 (2007~)
	X6
	i3
i8	
MINI	Cabrio (R50 2006~)
	Clubman
	Cooper (R56 2006~)
	Cooper S (R56 2006~)
	One (R56 2006~)
	Paceman
	Roadster

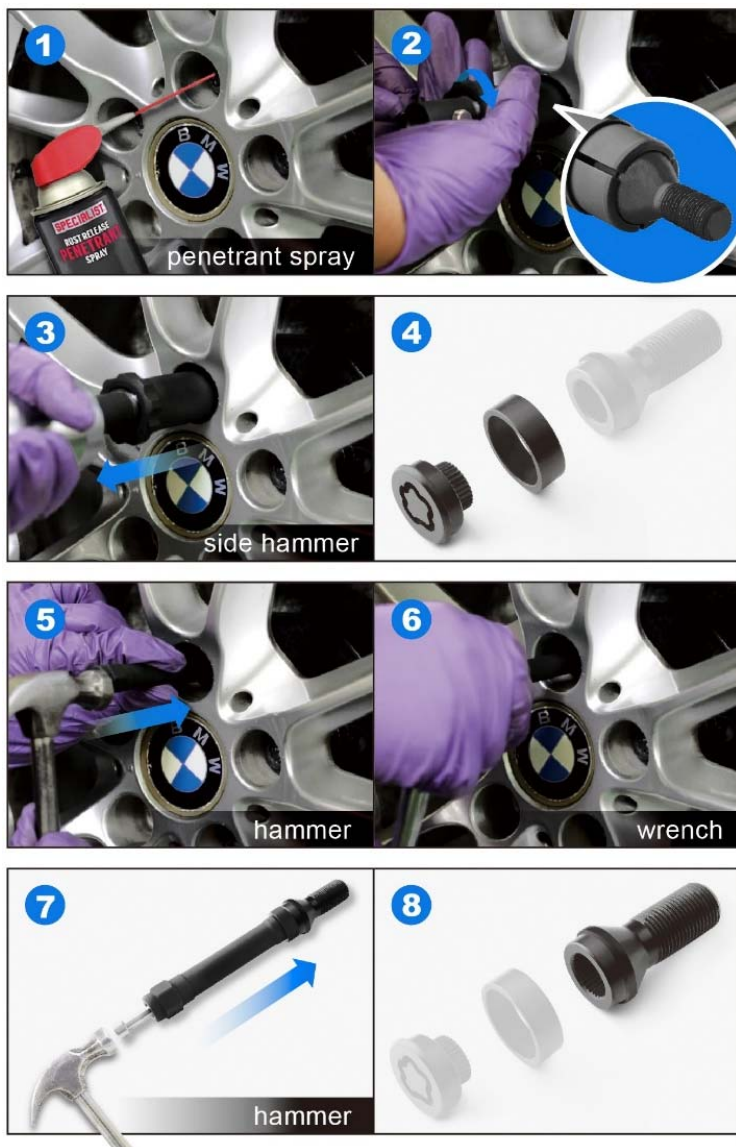



### **KA-6394A Piston Ring Compressor Set**

- Install pistons from 2-7/8" TO 4-5/8" (73mm TO 117mm).
- Ratcheting lock allows bands to compress in small increments.
- Can be used parallel vertically perpendicular horizontally.
- Set includes pliers and seven bands.
- Band Size:
  - A. 2-7/8" to 3-1/8" (73mm to 79mm)
  - B. 3-1/8" to 3-3/8" (79mm to 86mm)
  - C. 3-3/8" to 3-5/8" (86mm to 92mm)
  - D. 3-5/8" to 3-7/8" (92mm to 98mm)
  - E. 3-7/8" to 4-1/8" (98mm to 105mm)
  - F. 4-1/8" to 4-3/8" (105mm to 111mm)
  - G. 4-3/8" to 4-5/8" (111mm to 117mm)



#### **Optional Band:**

Item No.	Band Size
<a href="#">KA-6394A-B19</a>	114-121mm
<a href="#">KA-6394A-B20</a>	121-127mm
<a href="#">KA-6394A-B21</a>	127-133mm
<a href="#">KA-6394A-B22</a>	133-140mm
<a href="#">KA-6394A-B23</a>	140-146mm
<a href="#">KA-6394A-B24</a>	146-152mm



### **KA-5470**

#### **Universal Locking Wheel Nut Removal Kit**

- Very effective and a must have workshop tool.
- Kit includes shroud which protects the wheel against any damage.
- Simple to use master kit has the capability of removing practically any locking wheel nuts.



**KA-6348S**



**KA-6348M**

**Universal Thread Repair Tool**

- One tool restores inch or metric RH or LH threads.
- No calibration required.
- Self adjusting to any pitch & size within range.
- Automatically chases good threads to repair the damage.
- 60°, ISO, UNC, UNF, NPT
- 55°, BSW, BSF, BSP



**KA-6348S**

- 5/32"~3/4" (4~19mm)
- Pipe threads up to 7/16"

**KA-6348M**

- 11/16"~1-1/2" (17~38mm)
- Pipe threads 3/8"~1-1/8"

**KA-6348J**

**Universal Adjustable Thread Repair Tool**

- Quickly adjustable to any thread diameter & pitch within the size range indicated.
- Applicable to most thread standards – ISO, UNF, UNC, NPT, BSW, BSP & more 2 cutting blades (58RC) guided by the existing thread, re-groove the damaged part.
- No prior thread measuring is needed.
- Range:  
35~152mm (1-3/8"~6")
- Pipe: 1"~5-1/2"





### KA-4521 FUSO Flywheel Holder (Manual)

Use for holding flywheel to prevent from rotating.

#### Applicable:

FUSO EURO 5 lift cars/IVECO engine. (MANUAL)

FUSO NO.: MH063967

IVECO NO.: 99360306



### KA-4522

#### FUSO & IVECO Crankshaft Rear Oil Seal Removal Tool

- Use for installing IVECO F1C ENGINE / FUSO LIFT CARS(EURO 5) Crankshaft
- Rear seal installation.

#### Applicable:

Models: DAILY

IVECO OEM no.ref.: 99346259

FUSO NO.: MH063963



### KA-4523

#### Diesel Oil Filter Wrench For FUSO 401

- Use for removing the plastic case when replacing the filter.
- Size: 1/2" Dr. x  $\Phi$ 96.5 x 12PT

Applicable: FUSO 401/ Daewoo Bus.



### KA-4524

#### FUSO Crankshaft Front Oil Seal Installation Tool

- Use for installing crankshaft front oil seal.

#### Applicable:

FUSO EURO 5 lift cars / IVECO engine.

FUSO NO.: MH063962

IVECO NO.: 99346258



**KA-4525 FUSO Crankshaft Front Oil Seal Removal Tool**

- Use for removing front crankshaft oil seal.

**Applicable:**

FUSO EURO 5 lift cars/ IVECO engine.

FUSO NO.: MH063989

IVECO NO.: 99340059



**KA-4526 FUSO Diesel Injector Removal Tool**

- Use for removing the injector connector from diesel engine.

**Applicable:**

FUSO EURO 5 lift cars/ IVECO engine.

FUSO NO.: MH064377

IVECO NO.: 99342156



**KA-4527 FUSO Fan Clutch Holder (2 point)**

- Use for holding the clutch to remove the fan axial nut.

**Applicable:** FUSO EURO 5 engine

**FM number:** MH064219.



**KT-2908 5"**



**KT-2908A 10"**

**Contour Gauge**

- **Instant template**

Works well in copying the shape of irregular items, replicate the shape of moldings or match cut outs, providing you with accurate reads.

- **Flexible shaping measure ruler**

This contour profile gauge can be applied to copy or track the shape of irregular objects, with ruler on the top, you can quickly figure out the size of them, instant template for marking precise tile cut.



**KA-7850K9**

**Manual Brake Fluid Bleeder with Adapter / Fluid Receiver**



**Manual operation suitable for most vehicle brake system.**

- One set of universal brake fluid connector. (KA-7850-AD)
- Provide a standard European adapter with a 90° fitting for narrow space.
- Provided with a 1000cc fluid receiver (KA-7850-BT).
- A variety of brake fluid connectors suitable for different vehicle types can be selected.
- Capacity 3000cc tank with pressure gauge, can be read & control the air pressure in the tank more easily.
- Built-in a pressure release valve on the filler cap.
- Include 2 M special industrial hose with control valve & connector.
- Patent in Taiwan, China, Applications in EU and USA
- Change your brake fluid is a simple and easy operation if you have the right tool.
- One men in same step clear operate, non-spark, quick & safety.

**Operation:**



**Brake Filling Adapter Application:**

Item No.	Application
KA-7850-AD-A3 KA-7850-AD-A3EX	Alfa, Aston Martin, Audi, Bentley, Bugatti, BMW, Chevrolet, Ferrari, Flat, Ford, Jaguar, Kia, Lamborghini, Land Rover, Mazda, Mercedes-Benz, Mini, Porsche, Renault, Suzuki, Toyota, Volvo, Volkswagen
KA-7850-AD-T1	Buick, Cadillac, Chevrolet, Ford, Mazda, Oldsmobile, Pontiac, Saturn, Tesla
KA-7850-AD-MSX	Tesla
KA-7850-AD-M3	Tesla
KA-7850-AD-A1	Mitsubishi, Nissan Gasoline, Subaru, Pronto, Suzuki, Volvo S40 and V40
KA-7850-AD-A2	Chrysler, Dodge, Dodge Truck, Ford, Ford Truck, Hyundai, Infinity, Jaguar, Jeep, Kia, Lincoln, Mazda, Mercury, Mitsubishi, Nissan, Plymouth, Saab, Subaru, Suzuki, Toyota
KA-7850-AD-UN	Acura, Chevrolet, Geo, GMC, Honda, Hyundai, Infinity, Isuzu, Jeep, Kia, Range Rover, Mitsubishi, Nissan, Peugeot, Subaru, Toyota, Volkswagen

**Option**



**KA-7850-AD7**



**KA-7850-AD**

**Brake Bleeder Adapter**

**KA-7850-AD7**

with 7pcs adapters

**KA-7850-AD**

with 6pcs adapters

\* KA-7850-AD-A3 not includes



**KA-7850-BT  
Fluid Receiver**

- Material: PE
- Capacity: 1000c.c.



**KA-7850  
Manual Brake Fluid Bleeder**

- Capacity: 3000c.c.
- Come with a brake filling adapter (KA-7850-AD-A3EX)



KA-1379-12



KA-1379-15



KA-1379-12RV

**Plastic Wrench Rack**

- Hold up wrench for easy size identification
- Can also hang on a wall or carry to job.

Item No.	Slot	Type
KA-1379-12	12 pcs	Forward
KA-1379-15	15 pcs	Forward
KA-1379-12RV	12 pcs	Reverse



KA-1378-5



KA-1378-6



KA-1378-7



KA-1378-8



KA-1378-11



KA-1378-12

**Stubby Wrench Rack**

- Made from tough TPR plastic.
- Can also be hang on a wall or carry to job.
- Suitable for stubby wrench

Item No.	Slot
KA-1378-5	5 pcs
KA-1378-6	6 pcs
KA-1378-7	7 pcs
KA-1378-8	8 pcs
KA-1378-11	11 pcs
KA-1378-12	12 pcs



KA-1382



KA-1382-12



KA-1382-15



KA-1382RV



KA-1382-12RV



KA-1382-15RV

**TPR Wrench Rack**

- Made from tough TPR plastic
- Can also be hang on a wall or carry to job.
- Suitable for combination, geared, ring, open end and flare nut spanners.

Item No.	Slot	Type
KA-1382	8 pcs	Forward
KA-1382-12	12 pcs	Forward
KA-1382-15	15 pcs	Forward
KA-1382-RV	8 pcs	Reverse
KA-1382-12RV	12 pcs	Reverse
KA-1382-15RV	15 pcs	Reverse



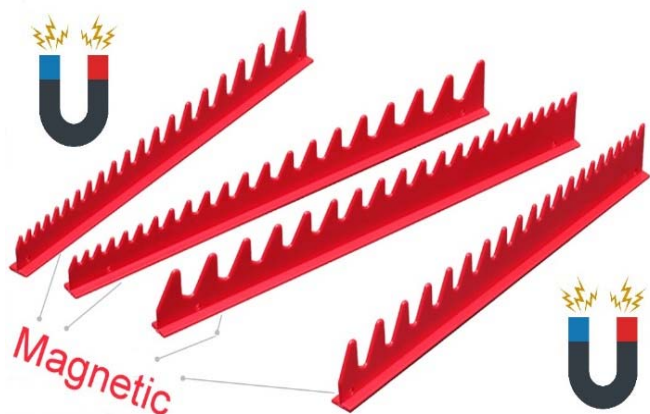

**KA-1379**

**4pcs Magnetic Sharks Teeth Wrench Rack**

- Durable composite sharks teeth spanner rack with magnetic strips, helps to maintain an organized topchest / rollcab.
- Easy to storage the wrenches, make them in order.
- Suitable for combination wrench, double end wrench, double open wrench and so on.
- Material: PP
- Content:  
2pcs -Forward type.  
2pcs -Reverse type



**KA-1380 Detachable Reversible Wrench Rack**

- Material: ABS, PP / 16 Slots
- Take up 30% more storage space.
- \* **Rail Detachable** \*



**KA-1376 Metal Socket Tray Rack - 40pcs**

- Organized classification sockets specification and placement.
- The surface uses a better texture power coating.
- With handle function, easy to carry tools to the workplace.
- The thin design of the socket tray can be placed in a low-height drawer of tool car or hanging on the wall

**Capacity:**

Hold up to 10pcs 1/4"DR. socket  
Hold up to 20pcs 3/8"DR. socket  
Hold up to 10pcs 1/2"DR. socket

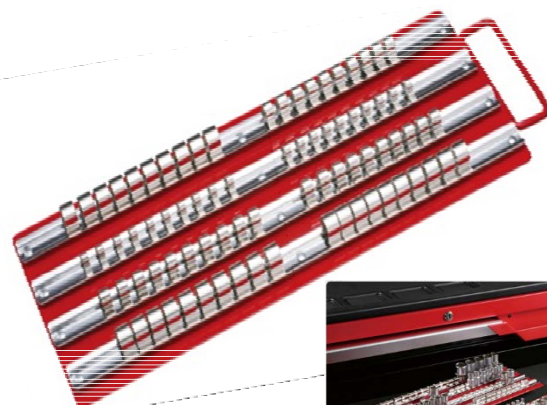

**KA-1377 Metal Socket Tray Rack - 80pcs**

- Organized classification sockets specification and placement.
- The surface uses a better texture power coating.
- With handle function, easy to carry tools to the workplace.
- The thin design of the socket tray can be placed in a low-height drawer of tool car or hanging on the wall

**Capacity:**

Hold up to 20pcs 1/4"DR. socket  
Hold up to 30pcs 3/8"DR. socket  
Hold up to 30pcs 1/2"DR. socket

### KA-1383 Magnetic Multi-Carrier Panel -

- 305x152mm Magnetic Panel
  - Material: steel
  - Color: Black
  - Contents:
    - 1/4"Dr. clip x 12pc
    - 3/8"Dr. clip x 12pc
    - 1/2"Dr. clip x 12pc
  - Color: Black panel with black clip
  - Unit Packing: Color Box
- Application demonstration: (Tools not included)



Studs can be adjusted to any position

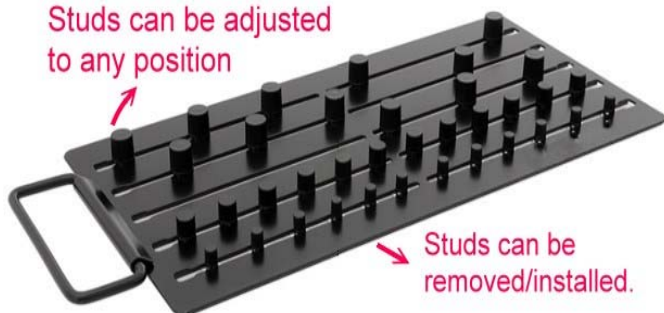

Studs can be removed/installed.



### KA-3822 Heavy Duty Locking Ring Tool

- A new tool designed to dismount & mount the **Large** lock rings on the axle shaft of passenger cars, light commercial vehicles and trucks.
- The adjusting screw has a 3/8" ratchet grip providing sufficient power to easily remove stuck and rusted lock rings.
- The grip angle between the tips are always correct, regardless the size or placing position of the lock rings.
- This feature makes this set a safer, more effective and easier tool comparing using other ordinary pliers.
- This tool include 18 tips (6 lengths in 3 different angles)

Circlip Pin Size: (each 2 pcs)

- Straight: 2.2mm, 2.5mm, 3.0mm, 3.5mm, 3.8mm, 4.2mm
- 45° Angle: 2.2mm, 2.5mm, 3.0mm, 3.5mm, 3.8mm, 4.2mm
- 90° Angle: 2.2mm, 2.5mm, 3.0mm, 3.5mm, 3.8mm, 4.2mm



### KA-7860 Internal Coil Spring Compressor

Applied to big coil springs, For spring diameter Ø75-155mm

- Suitable for coil springs with internal diameter > Ø75mm and external diameter < Ø155mm.
- Special pins on tool body to mesh with grooves on discs to create a secure connection.(see illustration on the right)
- Can be operated with an air/impact wrench.
- Provided with product liability insurance.
- Break point: 12,900 kgf (ca. 126,505N)
- Max load: 6,525 kgf (ca. 64,000N)

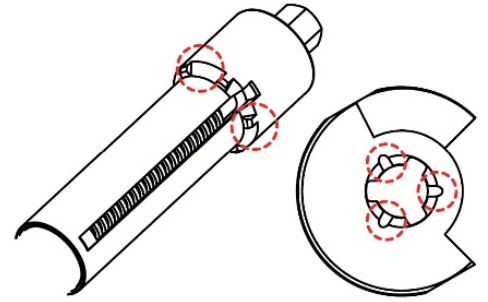

Specification:

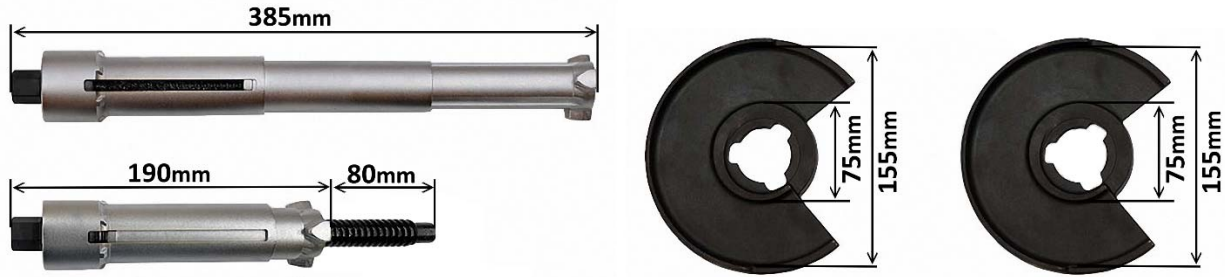

Instructions:



Place upper and lower discs on spring.



Insert the main tool body into the spring.

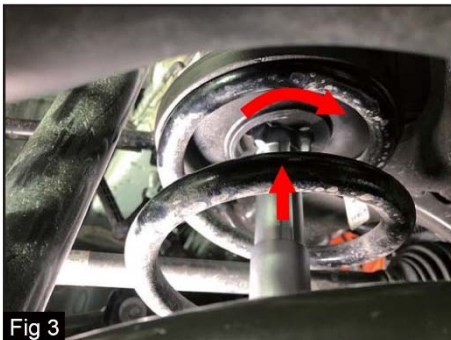

Fig 3



Fig 4

Insert through the disc and make a half turn to connect the tool and disc (Fig.3). Turn the hex nut on the main tool body lower end to fix all parts (Fig.4).



Fig 5

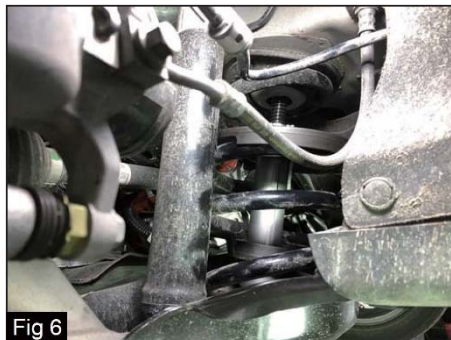

Fig 6

Use an air/impact wrench to compress the spring (Fig.5 and Fig.6).

Applications:

Alfa Romeo	Giulietta	2010-2020
Audi	A4	2001-2015
Audi	A6	2004-2011
BMW	3 Series E46	1997-2007
BMW	X6 E71	2007-2014
Chevrolet	Cruze	2009-2020
Citroen	Berlingo	2008-2020
Fiat	Doblo	2010-2020
Ford	B-Max	2012-2020
Ford	Galaxy	2006-2020
Hyundai	Santa Fe	2001-2006
Mercedes	A-Class W176	2012-2019
Nissan	Murano	2007-2014
Opel	Combo	2012-2020
Peugeot	Expert	1996-2006
Renault	Modus	2005-2020
<b>Tesla</b>	<b>Model 3</b>	<b>2017-2020</b>
Volvo	XC70	2007-2020



### KA-6870

#### Adjustable Hook And Pin Wrench Set

- Hardened and tempered drop-forged Chrome Vanadium steel.
- Specially designed for use with slotted retaining rings.
- Hook and pin interchangeable hinged arms with three wrenches covering sizes 19-120mm (3/4"~4-3/4").
- Pin Sizes: Ø4-8mm.
- Supplied in tough storage case.
- Designed for use on slotted retaining rings found on motorcycle suspension and other machinery.
- Time saver.



### KA-4000

#### Long Reach Harmonic Balancer Installer for Ford EcoBoost

- This tool is perfect for hard to enter areas, particularly on FWD vehicles.
- Easily assemble the harmonic balancer on to the crankshaft of multiple Ford EcoBoost engines
- The tool was designed for easy installation of harmonic balancers of Ford EcoBoost and various other Ford/ Lincoln engines from 2011 till now.
- Applications: 2.7L, 3.0L, 3.3 L, and 5.0L engines in Ford/Lincoln cars, trucks, and SUVs.



### KA-6397A Master Freeze Plug Installer Kit

- Forged with S45C and fully-plated to prevent rust.
- Designed to dismantle and assemble freeze plugs used in liquid-cooled gas and diesel engines.
- Content:  
2 Knurled Shafts (8" and Angled 18")  
Knurled Ring Nut End: 3/4", 1", 1-1/4", 1-1/2", and 1-3/4"
- No Need to dismantle head or manifold again.

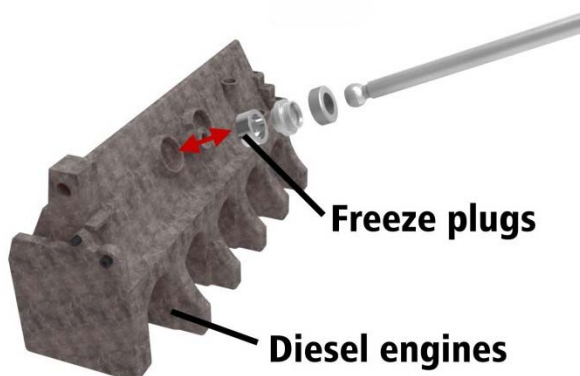

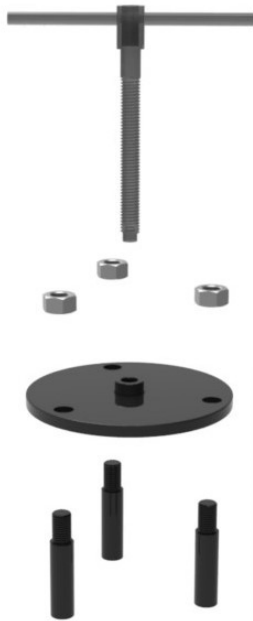

**KA-3663Q 6 Holes Hub Separator**

- Removing the 6 holes HUB rear axle.
- Save Labor and Working time. .
- Application :TOYOTA HIACE 100 series, 200 series, NISSAN CARAVAN E25,series,E26 series.
- P.C.D:139.7mm
- Thread specification: M12X1.5

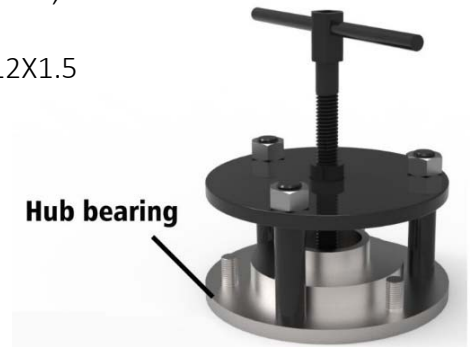

**KA-3663Q2 6 Holes Hub Separator**

- Removing the 6 holes HUB rear axle.
- Provides the mechanical advantage.
- For Disc brakes
- P.C.D:139.7mm
- Application: TOYOTA HIACE 100 series,200 series NISSAN CARAVAN E25 series,E26 series



**Hub bearing**

**KA-4143 A/C Clamp Remover**

- Fits both high and low edge clamps.
- Suitable chamfer opens clamps.
- For dismantling line clamps found on Toyota Tacoma (2015-2018).

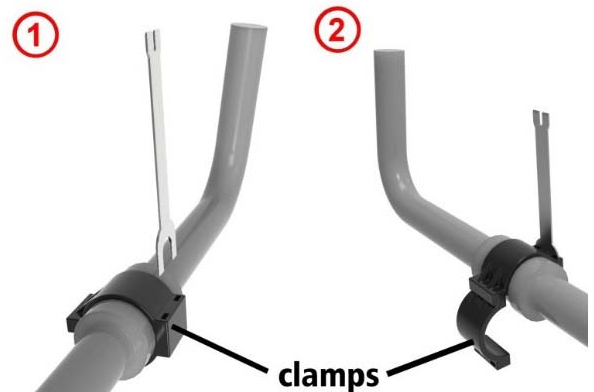



- 1. On/Off Switch
- 2. Power Indicator (Green)
- 3. Start Heating Button



- 4. Heating Indicator (Yellow)

- 5. Baby Oil Inlet
- 6. Fuse (8A)
- 7. DC 12 Power Connector
- 8. Smoke Outlet



### KA-9073A Smoke Leak Detector Set

A Great Tool to trace any leaks in automotive pipe systems such as air intake, fuel system, exhaust system, vacuum system.

**Step 1.** Connect the 12V Car Battery:

- Clip the **RED** battery to the positive pole (+).
- Clip the **BLACK** battery to the negative (-).

**Step 2.** Switch ① the power (ON):

The ② Power Indicator turn **GREEN**.

(If you connect the pole wrongly, the **YELLOW** light would on)

- The machine is equipped with protection device , so it will not be damaged if connect pole incorrectly.
- If you are using this machine for the **FIRST** time, please inject 1-2ml baby oil in ⑤ Baby Oil Inlet. Then fill 0.5-1ml for each time.
- **Please use Baby Oil ONLY!!**

**Step 3.** Start Heating to Produce Smoke:

Press the ③ Start Heating Button, ④ Heating Indicator light turns **YELLOW**.

It would reach workable smoke volume after **90** seconds, then press the ③ Heating Button again to stop heating.

- The machine would stop automatically after 5 minutes . Repeat Step 4 as needed, and fill baby oil according the smoke.
- Clean the Smoke Tube with dust gun after each use. The residue hardening baby oil cause clogs in tube.

Rubber Pipe Plug



Inflate Ball Stopper



Power Cord



Smoke Tube



Baby Oil (200ml)



Storage Case included



### KA-2216 Spot Weld Chisel

- Flat Splitting tool for the Manual Cutting of Spot Welds.
- For Panel Splitting
- THICKNESS:7.5MM, WIDTH: 26MM, LENGTH:240MM, Great to use with Hammer
- Made of CR-MOLY
- Hardened and Tempered



### KA-1366 Turbo Power Foam Gun

- Produce Rich and fluffy Foam that "Wrap" the dirt to Remove the Dirt easily and completely.
- Remove the Automotive/Motorcycle/Scooter body dirt and stain easily.
- Professional Automobile Detailing
- Excellent for Construction/Building/Wall Bricks/Wall Dirt Removal
- Fast and Efficient.

#### Feature:

1. Light and Durable Aluminum Housing.
2. Max Pressure: 15 Bar
3. Large Volume: 1000ml

Working Pressure 0.3~1.5Mpa(3~15Bar)

Material Body:Aluminum alloy  
Bottle: HDPE (1000 ml)

Port size ¼ G

Air Consumption 8Bar≥300L/M

Temp Range -5~+60°C (Non frozen)

Shooting Range 2.5M (inlet 5Bar)

### KA-5388 TOYOTA,LEXUS FUEL TANK LID TOOL

- Remove and Assemble the fuel tank lock rings.
- For most TOYOTA and LEXUS Vehicles
- Size: 1/2" DR x 24PT.
- Applicable: TOYOTA, Corolla, Land Cruiser, Matrix, Tacoma, Yaris S, Yaris Base, VIOS

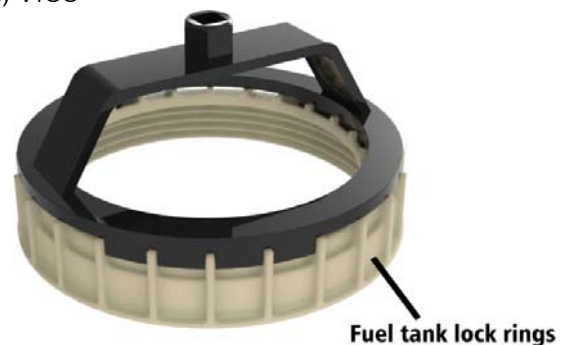

**KA-5062 HEAVY DUTY HYDRAULIC VALVE LIFTER REMOVER**



- Knurled handle for firm and anti-fatigue grip.
- Specially designed slide hammer easily tight firm or struck lifters.
- Expandable Collets to firmly grasp the hydraulic valve lifters.

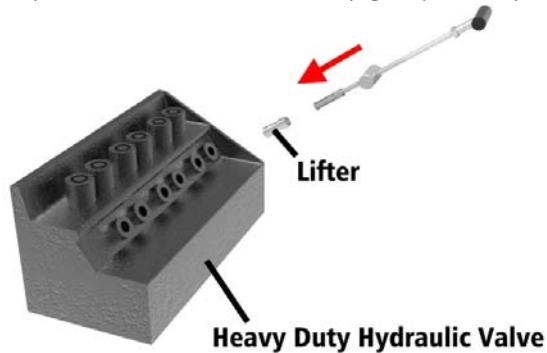

**KA-1375 SPINDLE SNAP RING PLIERS FOR FORD SUPER DUTYK**



- Ratcheting lock mechanism holds the snap ring open for plain extraction and installation.
- For changing the spindle snap rings found on 2007 and newer Ford Super Duty Pickups.
- Install snap ring within 2-1/2" diameter of the hub.
- Rigid plier device.
- Slender thin tips provide easy installation.

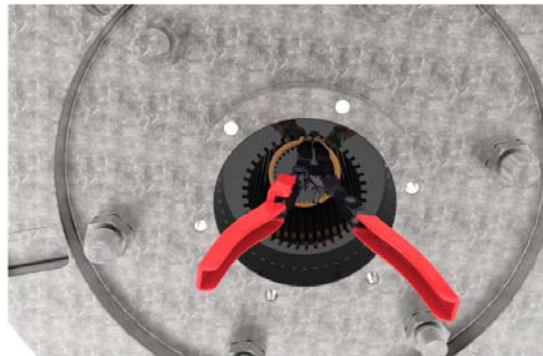

**KA-3935A SPINDLE SNAP RING PLIERS FOR FORD SUPER DUTY**



- 1/2" Drive
- Use this socket with Breaker bar or Drive Ratchet.
- This non-marring, aluminum tool revolves the crankshaft in correct direction, when the balancer is off.
- Easy Installation

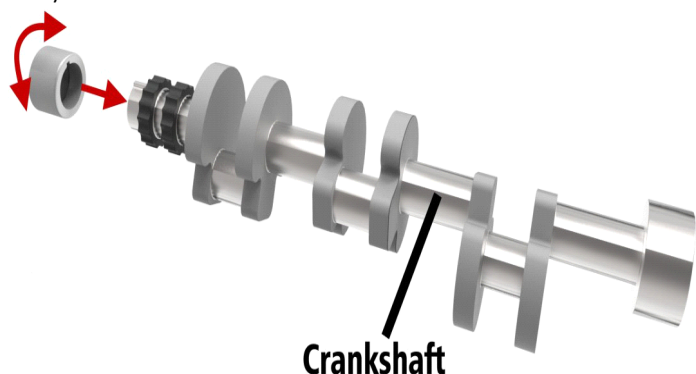





**KA-3277C Push Pin Pliers – Flat Degree**

- Designed to remove center locking pin type fasteners.
- Improved access to tight places.
- Prevents damage to fasteners and surrounding trim.
- Ergonomic coated handle prevents fatigue during long use.
- Applications: Chrysler, Honda, Toyota, GM, Ford and other late model vehicles.
- Also Available:  
 KA-3277: 30 Degree Push Pin Pliers  
 KA-3277A: 80 Degree Push Pin Pliers



**KA-2217 Wheel Bolt Lock Socket Set (10 pcs/set)**

*For Tesla Vehicles*

- This tool enables you to permit servicing of customer vehicles, even customer has lost the key.
- Content: #76, #77, #78, #79, #80, #81, #82, #83, #84, #85



**KA-2210AB Axle Popper Kit**

- Fork Design Applying Even Pressure to Both Sides of the Shaft and Allow Removing the Shaft Easier and Safer.
- To release the half shaft:
- Strike the Axle Popper Wedge or use Axle Popper Wedge as a Pry Bar to Release the Half Shaft
- Shim included for use on filling the gap between the half shaft and trans-axle
- Safer than Using Pry Bar
- CONTENT: Fork Shaped Axle Popper, Axle Popper Wedge



**KA-3823 Tyre Tread Depth Gauge**

- Measure tyre profile depth.
- Measuring depth 30mm.
- Graduation in 0.1mm steps show an exact determination of the tread depth.
- Glare-Free Reading
- Sturdy, Robust, Lightweight, Easy to handle.
- Material: Brass



## KA-2212 Ball Joint Service Kit



- Special designed for the removal and installation of press fit parts ball joints, without having to resort to makeshift methods.
- The ball joint service kit is applicable to Sportsman XP, RZR and Ranger models.
- Made from high quality steel that will resist the high pressures involved with ball joint service.
- This tool exactly squeezes the new ball joint into place without damage.

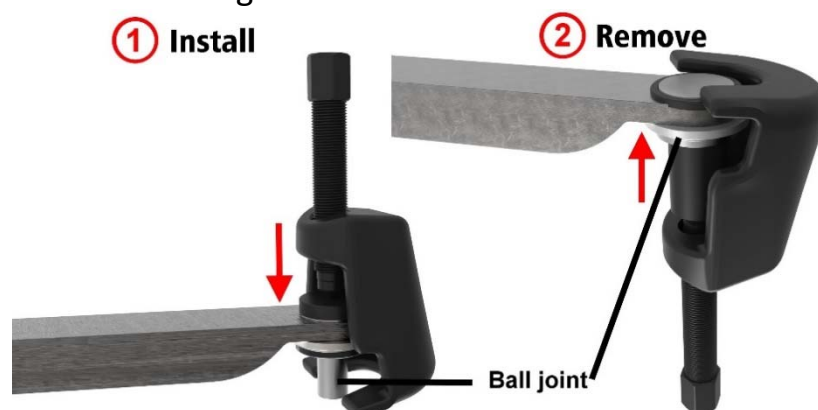

## KA-2213 Lower Arm Ball Joint Separator



- Forged steel body and lever provide an excellent performance and long usage.
- This press segregates the lower control arm ball joint from the steering knuckle.

- Jaw open: 60mm
- Works on many Ford, Lincoln.
- Works on Mercury Milan model years 2006, 2007, 2008, 2009, 2010 and 2011.
- Works on Montego model years 2005, 2006 and 2007.



### KA-2214 Harmonic Dampening Tool



- Keep crank pulley still avoid the harmonic damper pulley from revolving in the course of moving and installing the conclusive torque specification on the pulley bolt, allowing users to easily remove and install the crank bolt on many Toyota & Lexus engines.
- Grips the crankshaft while tightening the crank bolt.
- To tighten crankshaft pulley by 2 screws (M8 x1.25).
- Extend work needs 1/2" Dr. wrench.

### KA-2215 1/2" dr. NV4500HD Mainshaft 5TH Gear Nut Wrench For Dodge

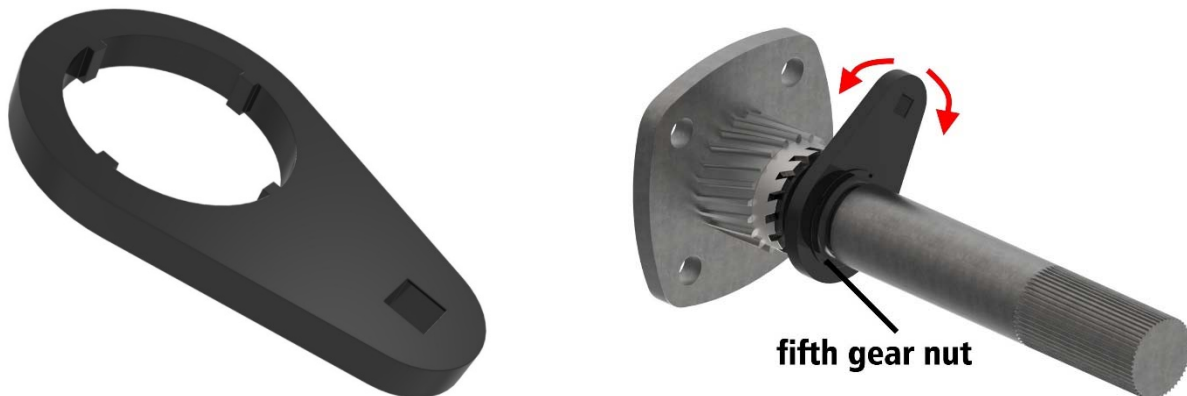

- Made of good quality steel.
- Mainshaft 5th gear nut wrench is a requisite to remove or assemble the mainshaft nut.
- It fits for NV4500HD transference used in Cummins and V10 powered Dodge RAM models have a large diameter mainshaft nut.
- It fits for 1994-2001 Dodge NV4500HD



### KA-2209A Crank Pulley Bolt Wrench

- It is a set that fixes the crankshaft pulley of SUZUKI, motor and can detach the crankshaft pulley bolt.
- This special tool has been made extremely thin in consideration of the narrowness of the engine room specific to mini vehicles.
- When tightening the crankshaft pulley bolt, a torque wrench can be used, but be careful of the tightening torque value.
- Application:  
WAGON R: LA-MH21S / ABA-MH21S / CBA-MH21S, 22S / UA-MH21S  
CERVO: CBA-HG21S / DBA-HG21S  
MR WAGON: CBA-MF22S, JIMNY: ABA-JB23W



### KA-1134PPS Small Piercing Probe

- Stainless steel tip can connect with the wire without cutting it.
- With 4mm socket connection.
- Wire: 20~28 Gauge
- Current Rating: 10.0 Amp



### KA-1135PPL Large Piercing Probe

- Stainless steel tip can connect with the wire without cutting it.
- With 4mm socket connection.
- Wire: 8~18 Gauge
- Current Rating: 20.0 Amp



### FLEXIBLE 10 GAUGE LEADS

- KA-1130-1FT Length: 1ft
- KA-1130-3FT Length: 3ft
- KA-1130-6FT Length: 6ft

## KA-5478 Adjustable Spark Plug Wire Puller



- Plier Jaws Adjustable to Five Different Angles/positions.
- Special Cushioned and Shaped Jaws gripping the Spark Plug Boots straight on or from other sides or any sides perfectly
- Plastic Handle Grip to avoid shock.
- Make SPARK PLUG BOOTS repair Easier!!



## KA-5479 Hydraulic Truck Floating Brake Disc Dismantling Set



- While changing truck floating brake disc (such as Volvo, DAF etc.), the brake discs always get stuck caused by rust or dust and hard to remove/dismantle.
- This set comes with two compact 14T hydraulic cylinders operated by a control block with individual on/off switch which allow the operators control one cylinder at a time to safely and effectively dismantle a stuck brake disc.
- Due to the compact size of the hydraulic cylinder, this set can be used not only on this purpose but also on those works which limited by space but need effectively expanding requirement.
- Applications include: The trucks equipped with floating brake discs such as Volvo, DAF, Renault, etc.

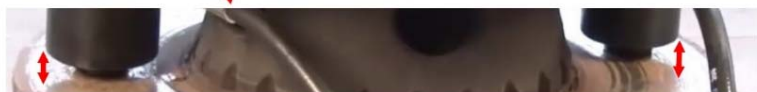
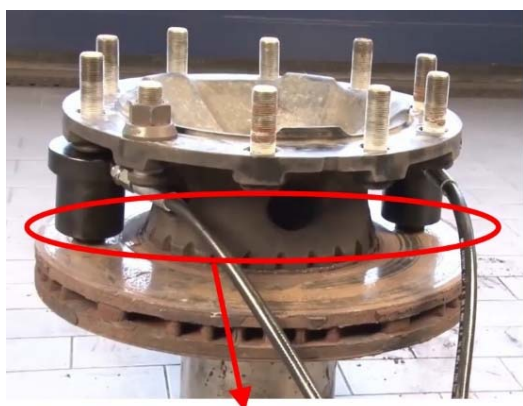

## KA-3818P 2 in 1 Molding Strip Tool

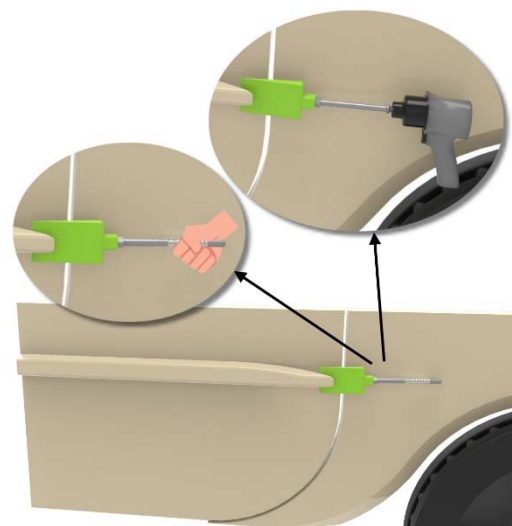

- Plastic Blade is Non-Marring and it won't Damage the Molding nor Scratch the Vehicle Body Paints.
- Wedge Angle Remove / Separate the Double-Sided Tape from the Door and Vehicle Body.
- Plastic Blade made with High Impact POM Structure Allowing Rigid Application with Mallet / Hammer.
- Pointed Wedge Edge Enables to be used under The Door Molding and Emblems.
- Attach the Plastic Blade with Impact Handle when using with Air Gun.
- Content: Plastic Blade, Manual Handle, Handle Shaft for Air Gun

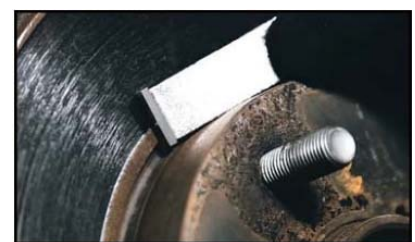
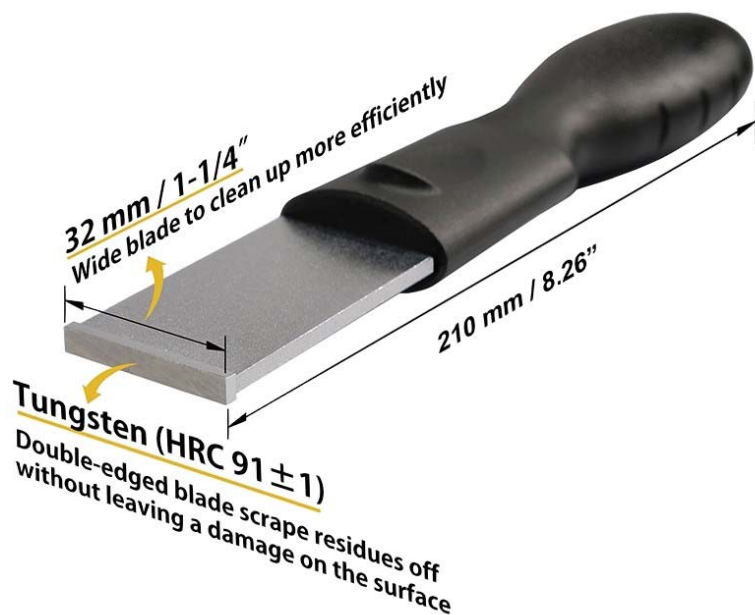

## KA-4531 Super Scraper

- To scrape off old silicone on oil pans, carbon buildup on exhaust manifolds, or rusts on brake calipers.
- Finely ground carbide double edges scrape residues off without leaving a damage on the surface.
- Premium tungsten carbide tip remains sharp for an extended period of time.
- Ergonomic handle design offers comfortable grip.

## KA-2210AB Axle Popper Kit

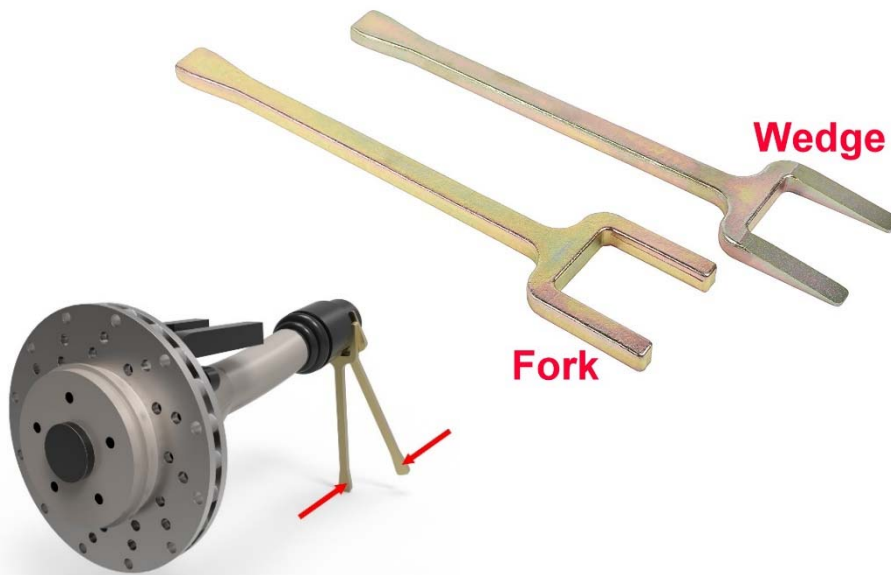

- Fork Design Applying Even Pressure to Both Sides of the Shaft and Allow Removing the Shaft Easier and Safer.
- To release the half shaft:
- Strike the Axle Popper Wedge or use Axle Popper Wedge as a Pry Bar to Release the Half Shaft
- Shim included for use on filling the gap between the half shaft and trans-axle
- Safer than Using Pry Bar
- CONTENT: Fork Shaped Axle Popper, Axle Popper Wedge

## KA-2210K Axle Popper Kit



- CONTENT: Fork Shape Pry Tool, Wedge Tool, Shaft (for Air Hammer)
- Fork Design Applying Even Pressure to Both Sides of the Shaft and Allow Removing the Shaft Easier and Safer.
- Tapered on Both Wedge Ends.
- Attach the shaft to Wedge to use with Air Hammer.
- Can be used with KA-2210AB.

## KA-3170A 2 in 1 Fuel Tank Lock Ring Kit



- An Innovative Great Tool with Multi-Application:
- Damage-Free to Remove and Re-Fit the Fuel Gauge Sender Collars.
- Easy to Remove and Install Lock Ring on the Fuel Tank when Servicing the Fuel Pump or Fuel Sending Unit.
- 2 Sets of Interchangeable Legs
- Channel Design body bar enable the Interchangeable Legs to Lock and Fit in Place to Secure the Drive Centered.
- Compact Size to Prevent Hanging over the Work Area and Eliminate the Possibility of Damaging other Parts
- Operation Range: Diameter 90-170mm
- Content: Channel Center Bar & 2 Interchangeable Set of Legs.



## KA-2211 Fuel Tank Lock Ring Wrench

- Great design allows tool to fit fuel tank lock rings on Ford, Chrysler, GM vehicles.
- Easily removes and installs lock ring on the fuel tank when servicing the fuel pump or fuel sending unit
- Application: 2004-newer Ford F-150 trucks. 2004-newer Chrysler / Dodge mini-vans, PT Cruiser, Dakota, Durango. 2004-newer Chevy 1/2-ton and 3/4-ton trucks.
- Used with a 1/2" Dr Ratchet or breaker bar.





### KA-8093 Sonic Belt Tension Meter

The sonic belt tension meter is able to measure the vibration of the belt from the microphone in the front. The meter will then use the mathematical calculation to convert the tension from the vibration of the belt, Which is helpful for installation or tuning of any belts.

**Features:**

- Portable Probe
- 20 sets Frequency Storage
- Maximum Frequency: 600Hz
- Automatically Power-off: The instrument will automatically power off when no operation for 5 minutes.
- User can also make the instrument power off by pressing On/Off switch for 2s.
- Power Source: 2 X AAA Battery

### KA-1074 Injector Tester



- Replaceable connector for different terminal.
- Power source: 12V vehicle battery.
- Operation environment: 0-40°C ; < 80% RH Storage.
- Environment: -10°C~50°C ; < 85%RH.
- The tester can help diagnose injector problems, you can use it to test each injector individually to help identify **stuck**, **leaking** or **burnt-out** conditions.

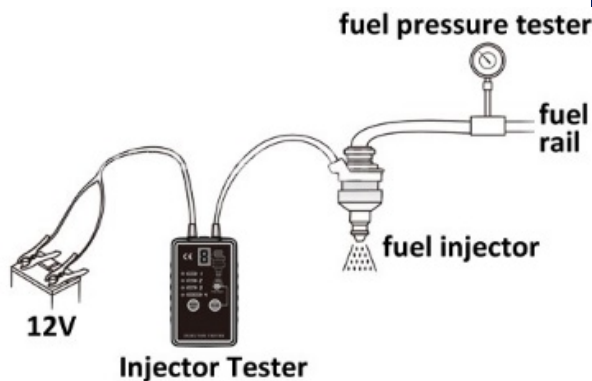

### KA-1075 Glow Plug Tester

- 6 LED to indicate the operating state of glow plug.
- Test without removing glow plug from engine.
- Power source: 12V vehicle battery.
- Indicate the condition of Short Circuit, Fault, OK, High Resistance, Open Circuit and Low Battery.

## KA-8092 Performance Tool Flywheel Turner



- Spring Tension Stabilizing the Tool on the Flywheel and Flex-Plate, Allowing Free use with Both Hands.
- Stabilize the Flywheel or Flex-Plate when Torqueing the Harmonic Balance Bolts or Flywheel.
- The Tools Folds for easy storage
- Easily Turn and Rotate the Engine from Underneath the Vehicle.

Flywheel



## KA-3761G Plastic Oil Drain Plug Tool Kit

A comprehensive 2pc kit specially designed to fit plastic oil drain screw plugs on popular commercial vehicles and passenger cars, such as DAF, MAN/NEOPLAN and Mercedes Benz. Sliding T-handle and interchangeable design provides extra leverage and easy-change direction and quickly changed from one to the other tool.

### Application:

DAF: 1853 604, 1982 821

MAN/NEOPLAN: 51.90310.6010

Mercedes-Benz OEM A 0029902017

Or some other vehicles fitted with same screw plugs.

Individual tool available upon request.



## KA-3886A 1/2" Dr. GM Water Pump Socket Disc Brake Pad Spreader

- Angled Teeth Prevent the Tool from Gliding.
- Remove and Install the Water Pump Assembly
- Application:  
1993-Current North Star 4.6 Liter,  
1997-Current Aurora 4.0 Liter
- 1/2" Drive size.

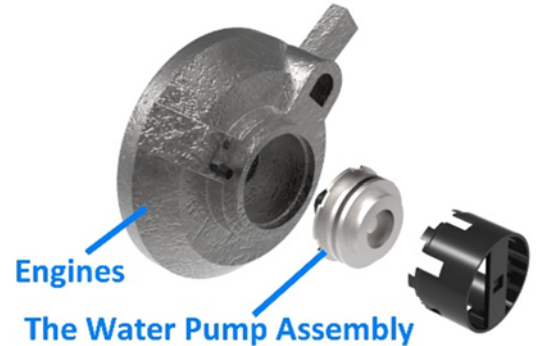

## KA-3821A Gear For Engine Flywheel Rotation

- System for dual gear engine flywheel rotation for IVECO timing search
- Engine models: 8040-25-45 / 8060-25-45 / 8460 / 8260 / 8280 / 8210.42 / 190.38 / 190.42
- Specific for Euro Cargo / Cargo Eurotech / Heavyon/ Off Road / Bus
- 2 gears



## KA-3821B Gear For Engine Flywheel Rotation

- For dual gear engine flywheel rotation for timing.
- Suitable for IVECO models
- Engine models: 8360.46 / F3A / F3B
- Suitable for Euro Cargo / Cargo 150E27R PR / FPR 320E27T / PT Euro tech / Eurostar models.

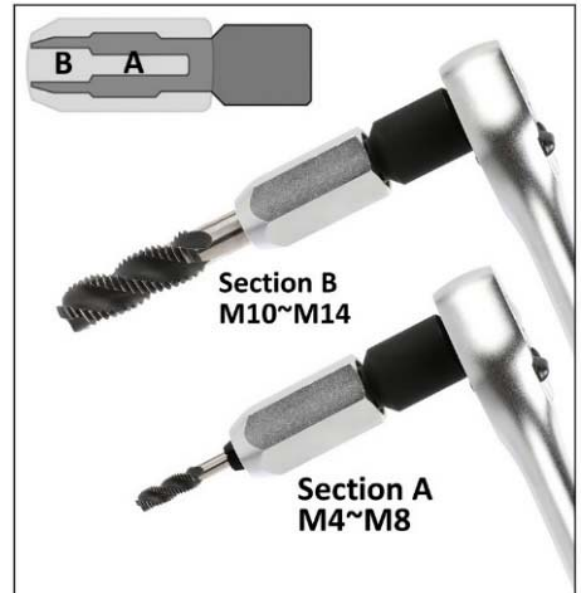

### KA-9074 Adjustable Tap Socket

- 3/8" Dr. x 19mm
- Designed for use with taps, reamers, screw extractors and other tools with a square shank.
- Two sections design fits common taps from M4~M14.
- Fits all 3/8" square drive tools.
- For use in tight workspaces.



### KA-2204 5pcs Utility Wedge Set

- For plastic upholstery fasteners.
- Place tool under edge of door panel and insert into fastener as fast as possible, and then simply pry up.
- Large support area to protect clips and pad.
- Steel



Clip Removal

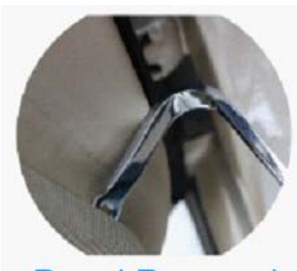

Panel Removal



Trim Removal

	Length	Width	Slot
KA-2004-1	174	23	11
KA-2204-2	190	23	11
KA-2204-3	173	14	7
KA-2204-4	173	14	5
KA-2204-5	173	14	5



### KA-4530 1/4" Dr. Crowfoot Wrench Set

- Used in hard to reach, confined spaces.
- Adapted to low torque applications.
- Including 1/4" Dr. breaker bar, 1/4" extension bar.
- Sizes: 7, 8, 10, 11, 12, 13, 14mm.



### KA-8413 Universal Clutch Alignment Tool



- Align the clutch disc either relative to the clutch pressure plate or via the pilot bearing relative to the flywheel.
- For single / two-disc clutches. (clutch hub  $\varnothing 15\sim 26\text{mm}$ ).
- For passenger cars and light commercial vehicles.
- For vehicles with / without pilot bearings.

**Content:**

No.	Description
1	Mandrel: $\varnothing 15\sim 19\text{mm}$
2	Spindle, Length: 100mm
3	Clutch disc aligning adaptor: $\varnothing 19\sim 30\text{mm}$
4	Mandrel: $\varnothing 20\sim 26\text{mm}$
5	Spindle: Length: 150mm
6	Clutch disc aligning adaptor: $\varnothing 26\sim 35\text{mm}$
7	Clutch plate aligning adaptor: $\varnothing 29\sim 69\text{mm}$
8	Pilot bearing extension adaptor, length: 20mm
9	Spindle, Length: 55mm
10	Pilot bearing adaptor: $\varnothing 10, 12, 14, 15, 16, 17, 19, 25, 27, 30\text{mm}$

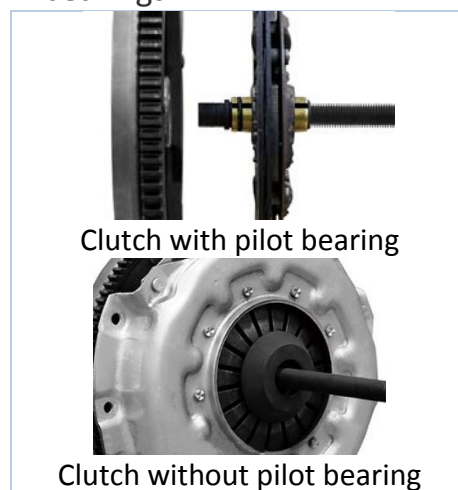

## KA-3819 Diesel Filter Wrench For Hyundai / Kai



- The wrench is designed specifically to service the fuel filter on Hyundai / Kai vehicles with 2.0L or 2.2L CRDi engine.
- 1/2" Dr.



Hyundai		Kia	
Santa Fe (TM)	2018~	Sorento (UM)	2018~
Palisade	2018~		



## KA-5337A Fuel Tank Locking Ring Tool

- This specialized tool is designed to remove and install the fuel tank locking ring of FCA group and Ford.
- Also allows the removal of the locking ring without lateral ribs.
- 1/2"Dr. x 21mm

<b>Alfa Romeo</b>	GT, 147, 156, 159, 166
<b>Fiat</b>	Grande Punto, Idea, Linea, Multipa, Panda, Nuova 500, Nuova Bravo, Panda 4x4, Punto, Sedici, Doblo, Croma, Stilo, Ducato, Doblo Cargo, Idea Van, Grande Punto Van, Multipla Van, Panda Van, Stilo Van, Scudo
<b>Lancia</b>	Y, Ypsilon, Musa Thesis
<b>Ferrari</b>	360 Spider, 430 Coupe, 430 Scuderia, 430 Scuderia Spider 16M, 430 Spider, 575 Superamerica, 575M Maranello, 599 GTB Fiorano, 612 Scaglietti, Enzo
<b>Maserati</b>	4200 Coupe, 4200 Gransport, 4200 Spyder, GranTurismo, Quattroporte

### KA-6789 AdBlue Filter Socket



- The socket is designed to remove and install the AdBlue filter (Urea filter) housing cap.
- Suitable for Mercedes commercial vehicles with BlueTec engines: Actros, Atego, Axor, Econic.
- 3/8" Dr. x 46mm



### KA-5473 Water Pump Sprocket Holding Tool

- For GM Ecotec - Europe
- Holds the timing chain & gear in place while removing or installing water pump on Ecotec Engines.
- Simply remove access place from front cover and install the tool.
- OEM Ref. EN-43651

Opel / Vauxhall		Chevrolet	
Antara	2011~2015	Captiva	2013~2015
Astra	1998~2015	Impala	2014
Omega	1994~2003	Malibu	2013~2015
Speedster	2001~2006	Orlando	2013~2015
Vectra	1996~2002		
Zafira	1999~2010	<b>GMV</b>	
Opel GT	2007	Terrain	2013~2015



**KA-5471****Solenoid Switching Valve Socket**

- Use for removing shift valve for controlling piston cooling.
- Suitable for Mercedes diesel engine OM651.
- 1/2" Dr. x 24mm.
- OEM Ref. 651589000900.



Shutoff valve for oil spray nozzle

**KA-5472 Tool For Positioning Electronic Clutch (Fiat C510 Dualogic)**

- To lock the selection lever inside the actuation hydraulic unit.
- The tool should be fully tightened and should not be removed to allow the hydraulic unit to be correctly fitted.
- Suitable for 1.3 MultiJet robotized gearbox (EURO 5).
- OEM Ref. 1871003400.



Undo the protection plug for the hydraulic unit selection lever locking tool.



Install the tool to lock the selection lever inside the actuation hydraulic unit.





Item No.: KA-4588

Patent: Taiwan

Masking Tape Edge Blending Folding Dispenser  
-Multi-Sizes: 14mm/15mm/18mm/28mm/30mm  
Masking Tapes

Features:

- ☆ One tool for 14mm/18mm/28mm/30mm Masking Tapes
- ☆ Gives Perfect Spray Transition
- ☆ Simple and Easy to Use
- ☆ Easy Maneuver, Compact, Fit in your hands!
- ☆ Effective, Time and Labor Saver, Eco-friendly

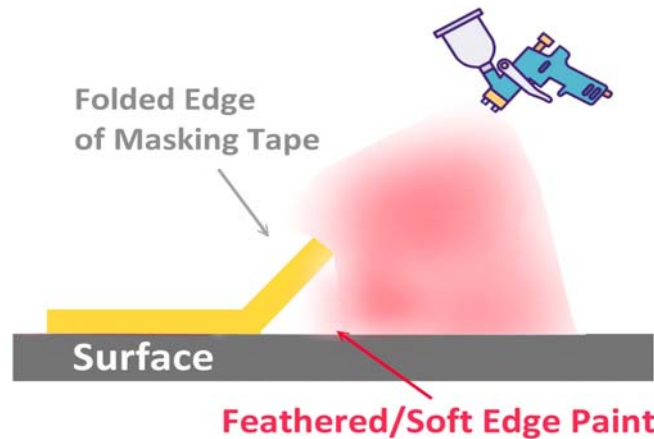

- Folds the edge in 2mm, 3mm, 4mm of Your Choice by folding a crease, thread through the opening and simply pull!
- Delivering uniform and constant size of folding edge all the way from ground zero till ends, no matter how far or shot you pull.
- The folded tape can follow curves or in circle nicely!!
- The Folded tapes can be used on door, bonnet, fuel tank, hood and even in folds..etc



With this KA-4588 Tape Edge Folder Dispenser, the tape edge is afloat slightly off the surface, and let the spray of paint to scatter and distribute along the tape line and gives the edge a smooth, feathered, blending, invisible transition results between sprayed and non-sprayed parts.

**No more sharp hard tape lines.**

Therefore, No further sanding action is required.

With other regular masking tapes (without folded edges), the paint spray always build up on the edge of the tape creating a raised ridge or stair step bumps of paint build-ups after the pain dried.

When the regular tape is removed, there leaves a line of dried paint equal to tape thickness. The line is rough and sharp edge that required to be painstakingly sanded to smoothen the edge. It cost time and money.

**Application for KA-4588 Masking Tape Edge Folder**

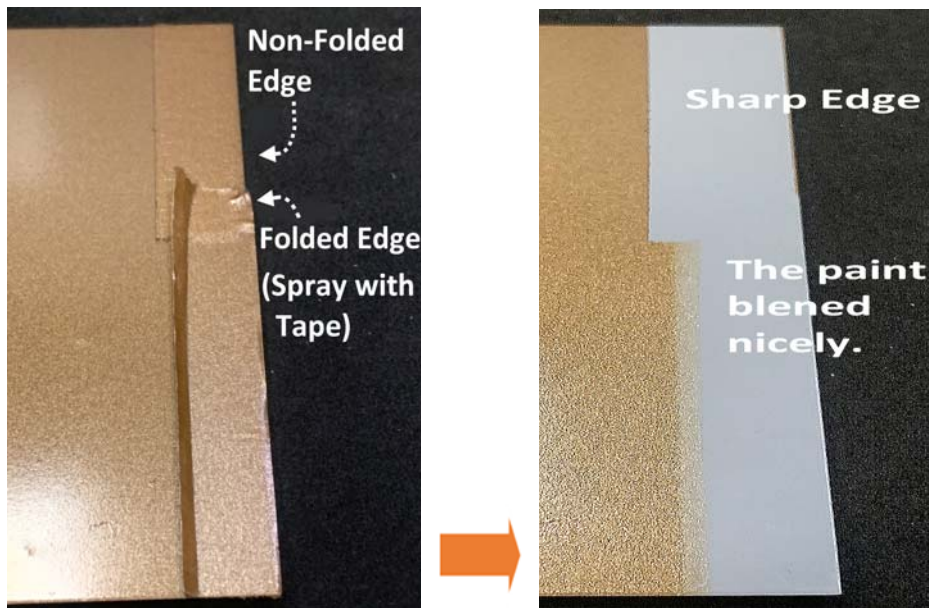

Part No.	<b>A</b>	<b>B</b>	<b>C</b>
Description	Cutter	Cap	Ring for tape core dia. ≥32mm
Picture			
Part No.	<b>D</b>	<b>E</b>	<b>F</b>
Description	Pad 12mm(H) x 65mm(OD) Pad 15mm(H) x 65mm(OD) Pad	Washer *4 pcs OD 40mm ID 25mm	Bearing*2 pcs OD 40mm ID 25mm
Picture			



## KT-N0005 Convertible Z Creeper

**Multi-Function**

Patent: TAIWAN,CHINA,U.S.A:9,061,413

**Flat Creeper - Shop Seat - Tool Tray (foldable)**

- Quickly & easily converts from creeper to shop seat.
- Weight Capacity : 450 IBS
- Foldable Tool Tray
- Six Ø3.0" swivel castors for easy maneuverability.
- 1" tubular iron construction.
- Dimensions : 43-1/4"l x 16" W x 6" H



## KA-9054S1 Creeper Seat

Patent: TAIWAN, Patent Pending: USA, China

- Adjustable creeper seat in two settings
- Weight capacity: 330 LBS
- Easy to transform
- Secure locks to promote safety
- 5 pcs 2.5-inch wheels
- Ground Clearance: 3-1/2"
- Dimension:

➔ In **High** Position:  
 Seat Height: 16-1/2"  
 ( L: 13-4/5" x W:14-1/2" x H:16-1/2" )

➔ In **Low** Position:  
 Seat Height: 5-4/5"  
 ( L: 19-1/5" x W :14-1/2" x H :16" )



## KA-9054S2 Creeper Seat

Patent: TAIWAN, Patent Pending: USA, China

- Adjustable creeper seat in two settings
- 3-position
- Adjustable tool tray on back
- Easy to transform
- Secure locks ensure safety
- 5 pcs 2.5-inch wheels
- Weight capacity : 330 LBS
- 3-1/2" ground clearance
- Dimension:

- ➔ In **High** Position: Height:16-1/2"  
L:13-4/5" x W: 14-1/2"x H16-1 /2"
- ➔ In **Low** Position: Height 5-4/5"  
L: 19-1/5" x W: 14-1/2" x H: 16"

High Position



Low Position



**Tool tray' height is adjustable & fold to retract.**



## KA-9054S3 Heavy Duty Tool Trolley

Patent: TAIWAN, USA:10,271,647

- Durable and comfortable cushion
- Sliding tool tray/drawers:  
Tray Inner Size: L:8-4/5"x W:10-1/5" x H:1"
- Weight capacity: 300 lbs.
- 1" tubular steel construction
- Slotted tool hanger on the back
- 3-position adjustable tool tray on both sides
- Dimensions: L:14-1/5 x W:11-2/5"xH:2-2/5"
- 4 \* Ø2.5" swivel castors for easy maneuverability



**Tool Tray can be set in two heights**

**Tool Hanger on the back**



## KA-9054S4 Heavy Duty Tool Trolley

Patent: TAIWAN, USA:10,271,647

- Durable and comfortable cushion
- Sliding tool tray/drawers:  
Upper drawer: L:8-4/5"x W:10-1/5" x H:1"  
Bottom drawer: L:9-1/4"x W:10-1/5" x H:4"
- Weight capacity: 350 lbs.
- 1" tubular steel construction
- Slotted tool hanger on the back
- 3-position adjustable tool tray on both sides
- Dimensions: L:14-1/5 x W:11-2/5"xH:2-2/5"
- 4 \* Ø2.5" swivel castors for easy maneuverability



Fold-up Side Trays



## KA-9054S5 Heavy Duty Tool Trolley

Patent: TAIWAN, USA:10,271,647

- Durable and comfortable cushion
- Sliding tool tray/drawers:  
→ Upper drawer:  
L: 9-1/4"x W:10-1/5" x H:2-3/4"  
→ Bottom drawer:  
L:9-1/4"x W:10-1/5" x H:4"
- Weight capacity: 350 lbs.
- 1" tubular steel construction
- Slotted tool hanger on the back
- 3-position adjustable tool tray on both sides
- Dimensions: L:14-1/2 x W:11-2/5"xH:2-2/5"
- 4 \* Ø2.5" swivel castors for easy maneuverability



Fold-Up Tray



## KA-4532

## Masking Tape Dispenser For Folding Soft Edge

- Tool for folding paint masking tape with a soft edge, which slightly lifts up the tape and allow the paint spray disperse.
- Special design automatically folds a soft edge when pulling the tape.
- Tape holder with  $\text{Ø}76\text{mm}$  / 3" suitable for holding most masking tape rolls.
- Seat with grooves for fasteners allows fixation on working tale or wall.



Masking tape is not included

